

**IIMI  
URBAN  
NOISE  
CONTROL**

# **PRODUCT CATALOGUE**

2026-2027

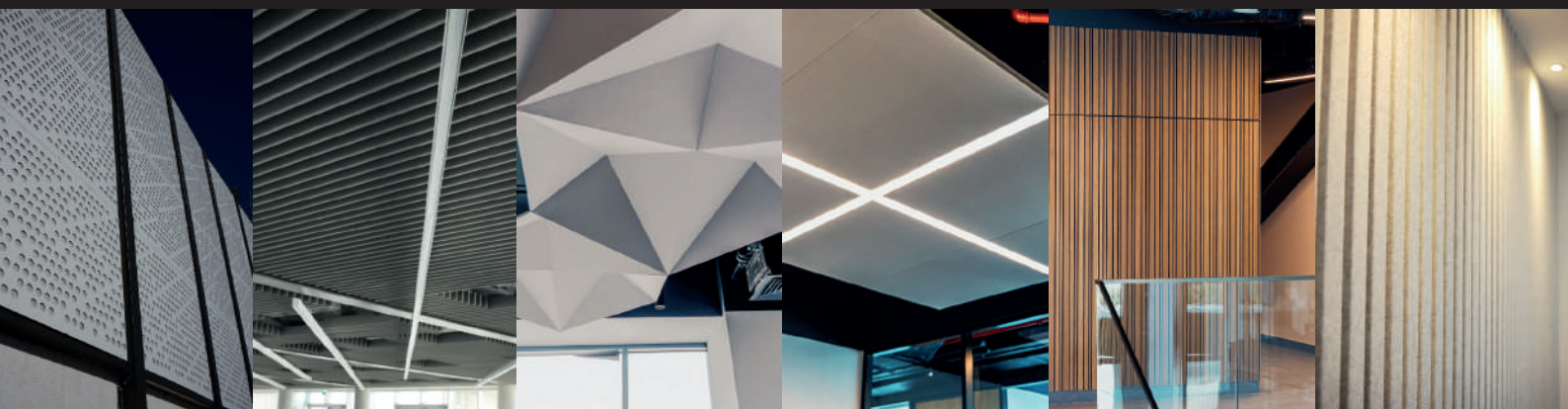

[www.urbannoisecontrol.com](http://www.urbannoisecontrol.com)

## ROOM ACOUSTICS

<b>POLYSOUND</b>	<b>1</b>
Grid tiles	3
Mosaic tiles	9
Engrave panels	17
Abstract tiles	27
<b>SOUNDWALL</b>	<b>33</b>
<b>MSYSTEM</b>	<b>41</b>
Linear	43
Twisted	51
Wavy	59
Beam	65
<b>MODULAR</b>	<b>71</b>
Edgy	73
Rhino	79
Curved	85
Cross	91
<b>TESSERA</b>	<b>97</b>
Flower	99
Polycloud	107
<b>EXTRUDED</b>	<b>113</b>
Beam	115
Bubble	121
Noisy	125

## ACOUSTIC PARTITIONS

<b>STAND ALONES</b>	<b>129</b>
<b>DESK DIVIDERS</b>	<b>139</b>
<b>BLINDS</b>	<b>147</b>
<b>DOORS</b>	<b>153</b>

## ENVIRONMENTAL & INDUSTRIAL ACOUSTICS

<b>METAL MUTE</b>	<b>159</b>
<b>FSS</b>	<b>167</b>
<b>COLOR PALETTES</b>	<b>178</b>



**GRID TILES**



**MOSAIC TILES**



**ENGRAVE PANELS**



**ABSTRACT TILES**



## POLYSOUND

---

POLYSOUND acoustic panels are manufactured from recycled PET, offering an environmentally responsible solution for improving acoustic comfort. Designed for installation on both ceilings and walls, the panels provide high levels of sound absorption while enhancing the visual character of any interior space.

Suitable for a wide range of environments—including private, commercial, and specialized spaces—POLYSOUND panels combine acoustic performance with modern design flexibility.

The panels are available in various shapes and formats, allowing them to be installed edge-to-edge without visible joints. This creates a seamless, continuous surface across walls or ceilings, delivering a clean and refined architectural finish.

POLYSOUND provides a visually striking wall and ceiling covering solution that balances acoustic efficiency, design versatility, and cost-effectiveness, making it an ideal choice for contemporary interior projects.





## GRID TILES

---

PET acoustic tiles designed to replace standard ceiling tiles in existing T-grid suspension systems, providing enhanced sound absorption and improved aesthetics.

The tiles are installed directly into the existing grid without modification, allowing for fast, clean, and non-disruptive installation. Available in a variety of colours, they offer flexibility for designers and consultants while upgrading the acoustic performance of the space.

This system provides one of the quickest acoustic upgrade solutions, combining efficient installation, acoustic performance, and visual versatility.



---

## AVAILABLE SIZES

---

### TILES

59 x 59 cm

### THICKNESS

12 mm or 24 mm

---

## MATERIALS AND COLORS

---

### MATERIALS

Polyester Fiber: 100% made from recycled PET

### COLORS

Refer to Polyester Color Palette at page 179.

---

## TECHNICAL SPECIFICATIONS

---



### INSTALLATION

Suitable for installation within suspended ceiling systems.



### SUSTAINABILITY

Panels manufactured from 100% polyester fibre, containing a minimum of 75% post-consumer recycled PET sourced from recycled plastic bottles.



### NON TOXIC

Tested according to BS EN 717-1 (E0) for formaldehyde emissions. The panels contain no chemical binders or formaldehyde, supporting safer indoor air quality.



### FLAME RETARDANT

Panels rated Class B-s1, d0 according to EN 13501-1, offering high fire safety performance for walls and ceilings.



### MAINTENANCE

Panels can be cleaned easily using a dust broom, vacuum cleaner, or a damp cloth.

## SOUND ABSORPTION

### POLYSOUND GRID TILES 12 mm

Sound class D ( $\alpha_w=0.30$ ) [according to ISO 354:2003 & ISO 11654:1997]

### POLYSOUND GRID TILES 24 mm

Sound class C ( $\alpha_w=0.61$ ) [according to ISO 354:2003 & ISO 11654:1997]

Absorption coefficient measurements

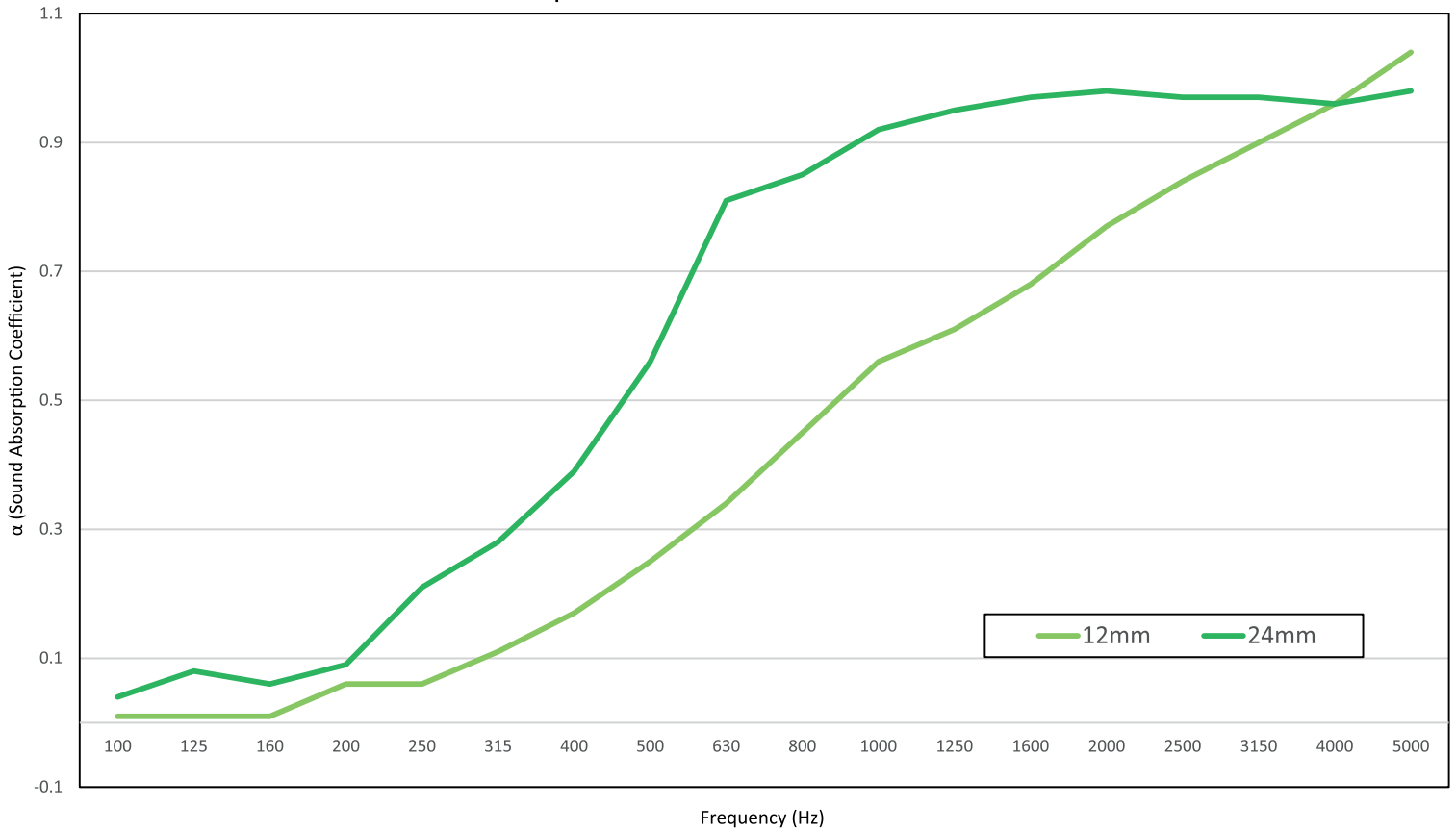

Frequency (Hz)	100	125	160	200	250	315	400	500	630	800	1000	1250	1600	2000	2500	3150	4000	5000
as 12 mm	0.01	0.01	0.01	0.06	0.06	0.11	0.17	0.25	0.34	0.45	0.56	0.61	0.68	0.77	0.84	0.9	0.96	1.04
	0.01			0.08			0.25			0.54			0.76			0.97		
as 24 mm	0.04	0.08	0.06	0.09	0.21	0.28	0.39	0.56	0.81	0.85	0.92	0.95	0.97	0.98	0.97	0.97	0.96	0.98
	0.06			0.19			0.59			0.91			0.97			0.97		



---

**STANDARD DIMENSIONS  
AND TYPES**

---

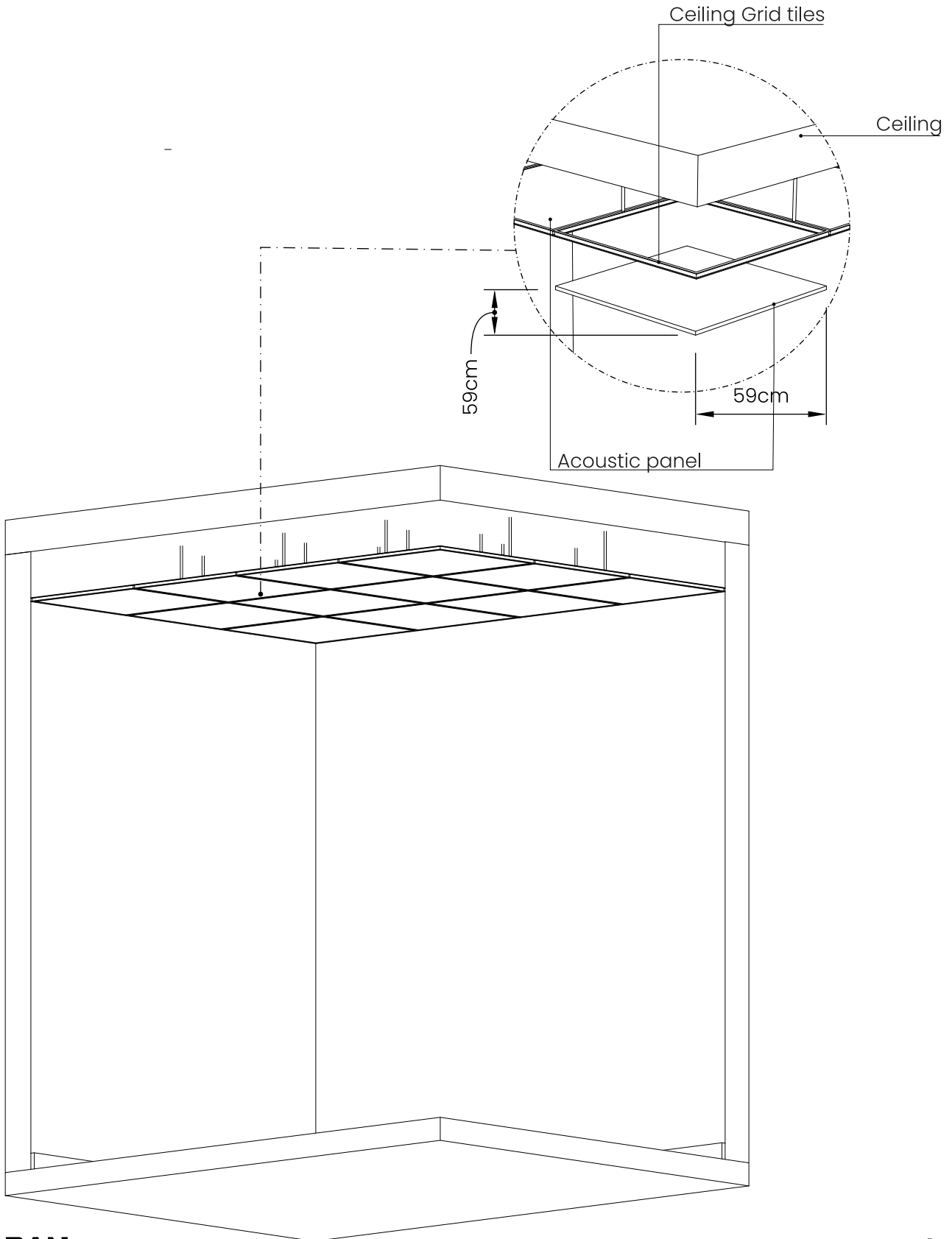



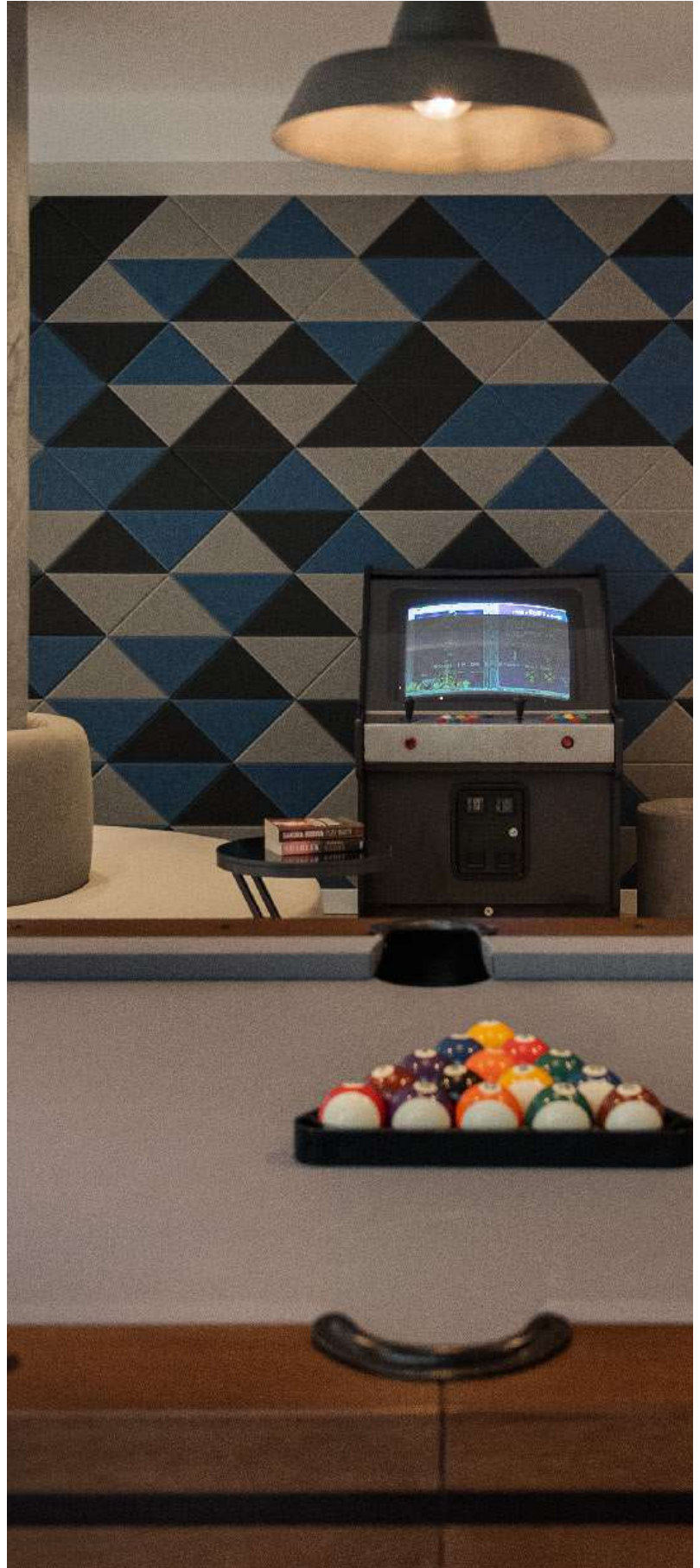

## MOSAIC TILES

Acoustic wall tiles available in hexagon and diamond shapes, designed to create a seamless and continuous wall panelling finish while providing effective sound absorption.

The panels are available in two different shapes and thicknesses, allowing the acoustic performance to be adjusted according to the project's requirements and space constraints.

A wide range of colours offers flexibility for designers, consultants, and clients to achieve the desired aesthetic outcome.



---

## AVAILABLE SIZES

---

### HEXAGON

20.5 cm (Diameter)

### DIAMOND

13.8 cm x 26.5 cm

### THICKNESS

12 mm or 24 mm

---

## MATERIALS AND COLORS

---

### MATERIALS

Polyester Fiber: 100% made from recycled PET

### COLORS

Refer to Polyester Color Palette at page 179.

---

## TECHNICAL SPECIFICATIONS

---



### INSTALLATION

Installation can be carried out by adhesive bonding to walls or ceilings.



### SUSTAINABILITY

Panels manufactured from 100% polyester fibre, containing a minimum of 75% post-consumer recycled PET sourced from recycled plastic bottles.



### NON TOXIC

Tested according to BS EN 717-1 (E0) for formaldehyde emissions. The panels contain no chemical binders or formaldehyde, supporting safer indoor air quality.



### FLAME RETARDANT

Panels rated Class B-s1, d0 according to EN 13501-1, offering high fire safety performance for walls and ceilings.



### MAINTENANCE

Panels can be cleaned easily using a dust broom, vacuum cleaner, or a damp cloth.

## SOUND ABSORPTION

### POLYSOUND MOSAIC TILES 12 mm

Sound class D ( $\alpha_w=0.30$ ) [according to ISO 354:2003 & ISO 11654:1997]

### POLYSOUND MOSAIC TILES 24 mm

Sound class C ( $\alpha_w=0.61$ ) [according to ISO 354:2003 & ISO 11654:1997]

Absorption coefficient measurements

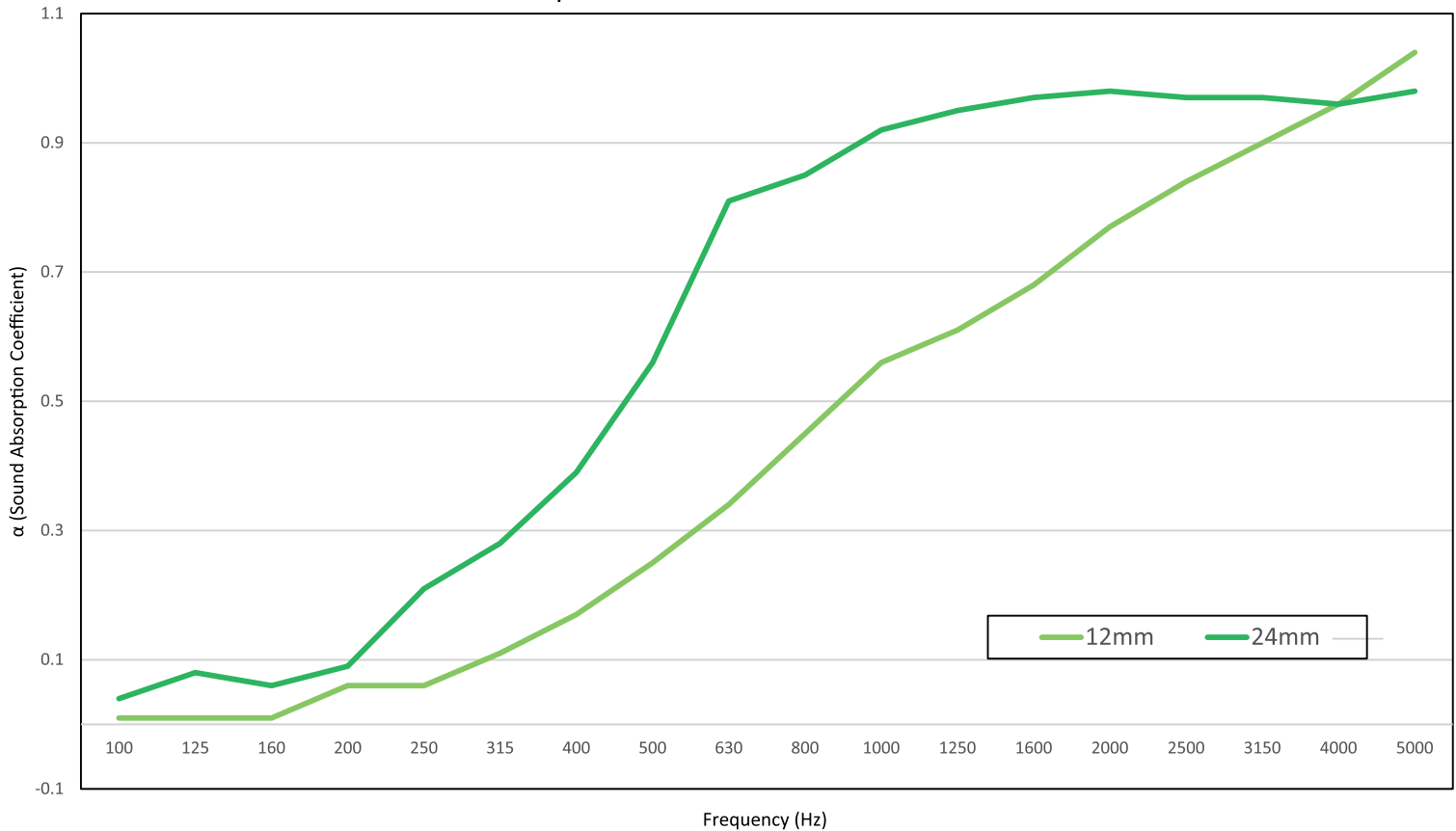

Frequency (Hz)	100	125	160	200	250	315	400	500	630	800	1000	1250	1600	2000	2500	3150	4000	5000
<b>as</b> 12 mm	0.01	0.01	0.01	0.06	0.06	0.11	0.17	0.25	0.34	0.45	0.56	0.61	0.68	0.77	0.84	0.9	0.96	1.04
		0.01			0.08			0.25			0.54			0.76			0.97	
<b>as</b> 24 mm	0.04	0.08	0.06	0.09	0.21	0.28	0.39	0.56	0.81	0.85	0.92	0.95	0.97	0.98	0.97	0.97	0.96	0.98
		0.06			0.19			0.59			0.91			0.97			0.97	



TIME: 99 PAGE: 069 / 130

- ▲ 0591 Silk Wars
- ▲ 0582 F-41 Phantom II
- ▲ 0593 Citivara Beast
- ▲ 0594 Citivara Beast
- ▲ 0595 Citivara Beast
- ▲ 0596 Citivara Beast
- ▲ 0597 Citivara Beast
- ▲ 0598 Citivara Beast
- ▲ 0599 Citivara Beast

P-BOX 6

FREE PLAY  
If Into Indonesia



---

**STANDARD DIMENSIONS  
AND TYPES**

---

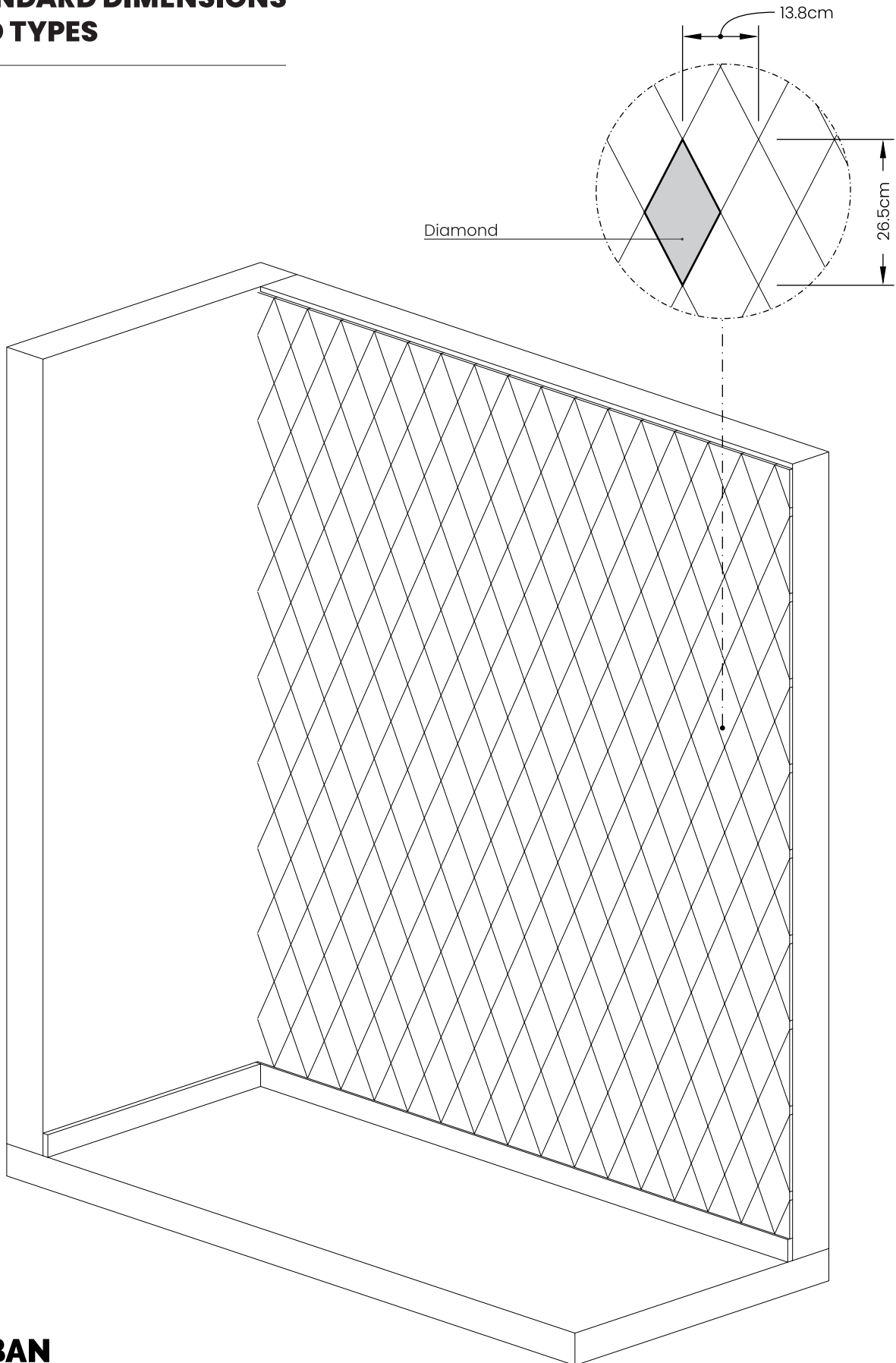



---

**STANDARD DIMENSIONS  
AND TYPES**

---

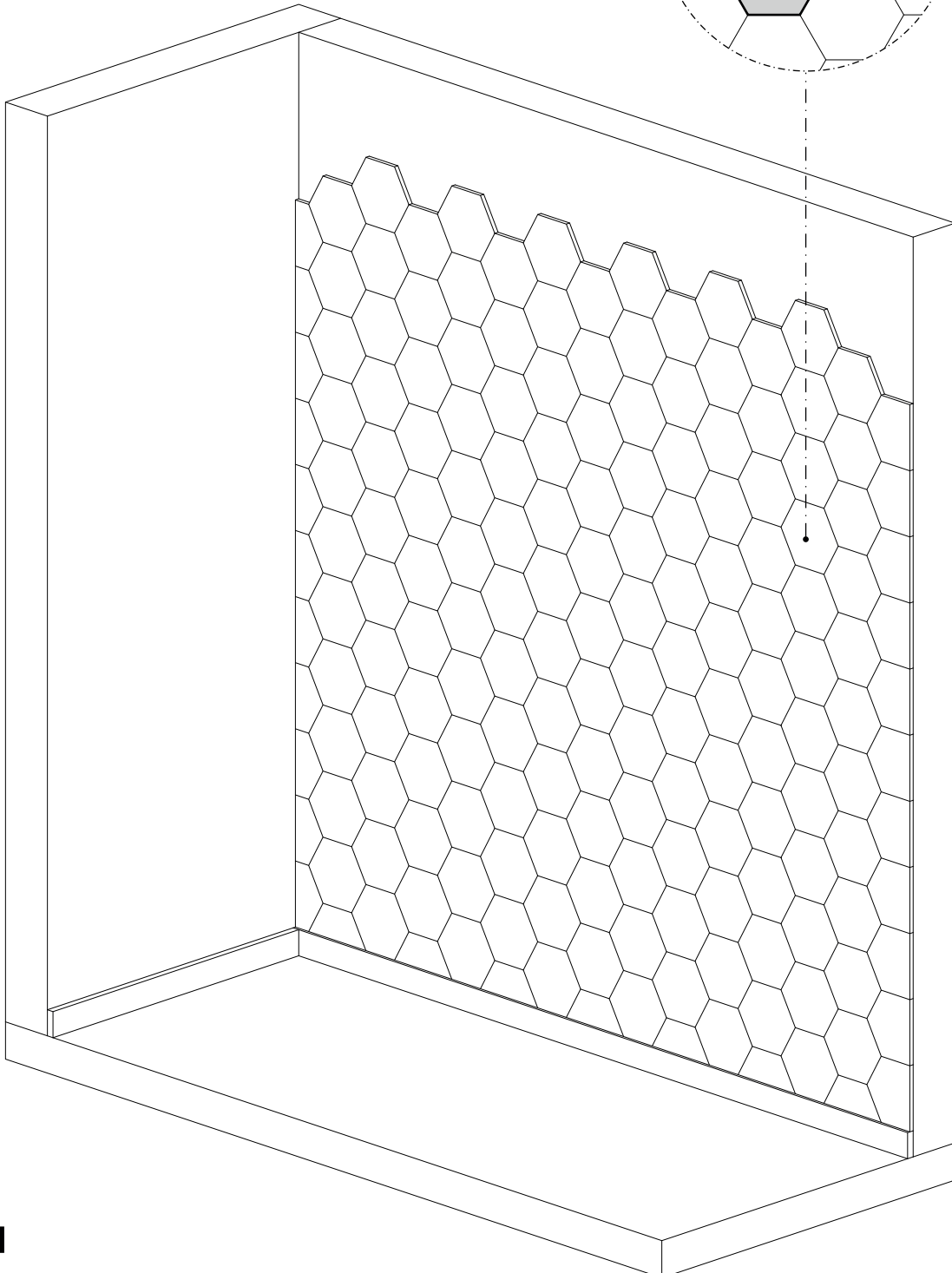
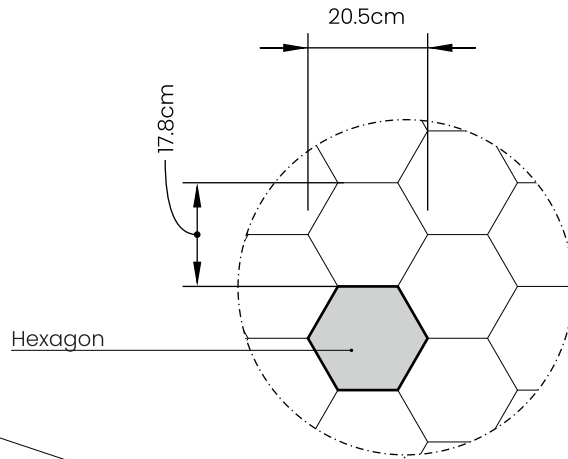



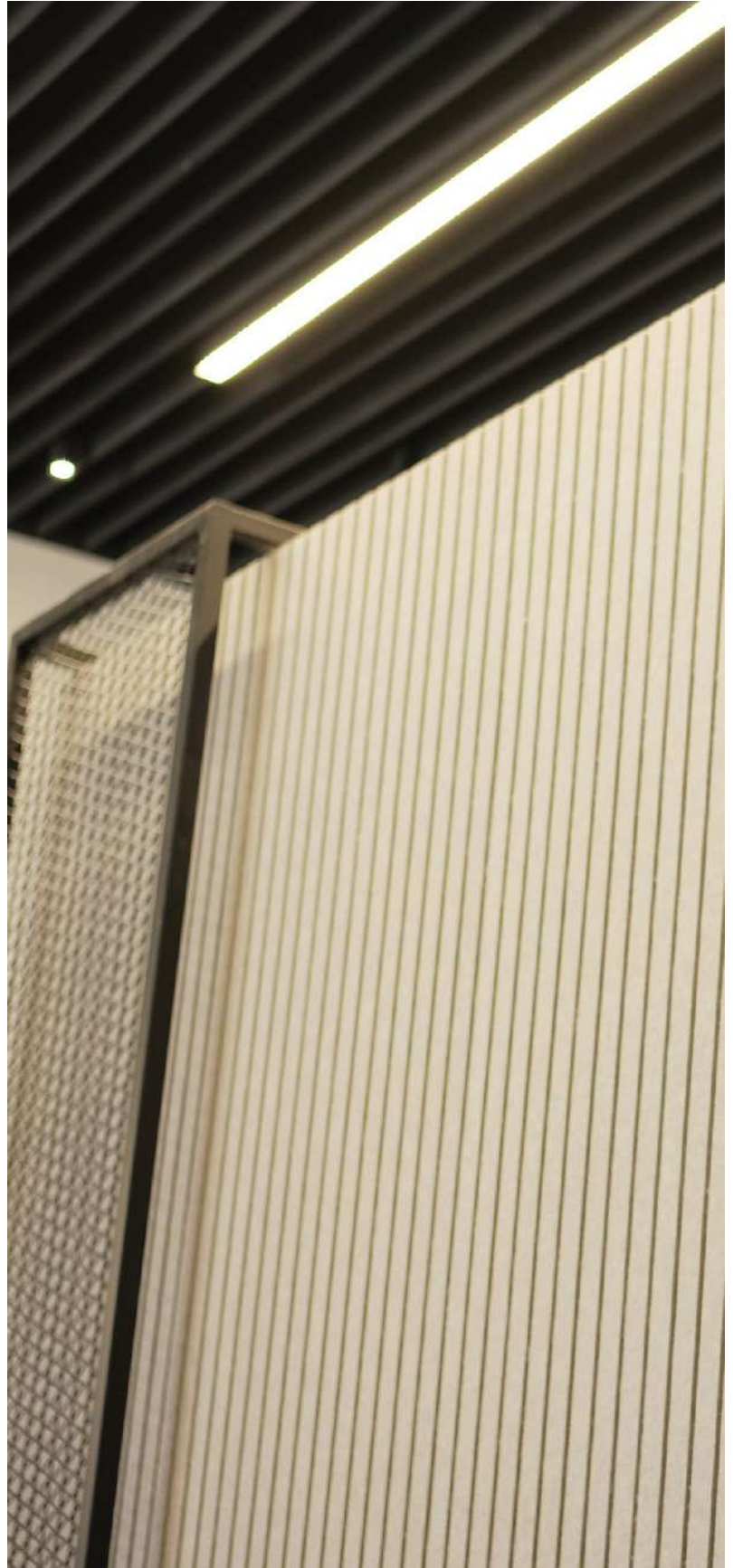

## ENGRAVE PANELS

Acoustic panels available in five formats — 30×10, 44×16, 24×16, 100×20, and 190×10 — designed to deliver effective sound absorption while creating a seamless, continuous finish across walls or ceilings.

The panels are manufactured in two thickness options, allowing the acoustic performance to be tailored to the specific requirements and spatial constraints of each project.

A wide range of colours provides design flexibility for consultants, architects, and clients.

## AVAILABLE SIZES

### PANEL

240 x 60 cm

### SHAPE CHARACTERISTICS

**30-10:** 3 cm solid – 1 cm engrave

**44-16:** 4.4 cm solid – 1.6 cm engrave

**24-16:** 2.4 cm solid – 1.6 cm engrave

**100-20:** 10 cm solid – 2 cm engrave

**190-10:** 19 cm solid – 1 cm engrave

### THICKNESS

12 mm or 24 mm

## MATERIALS AND COLORS

### MATERIALS

Polyester Fiber: 100% made from recycled PET.

### COLORS

Refer to Polyester Color Palette at page 179.

## TECHNICAL SPECIFICATIONS



### INSTALLATION

Installation can be carried out by mechanical fixing or adhesive bonding to walls or ceilings.



### SUSTAINABILITY

Panels manufactured from 100% polyester fibre, containing a minimum of 75% post-consumer recycled PET sourced from recycled plastic bottles.



### NON TOXIC

Tested according to BS EN 717-1 (E0) for formaldehyde emissions. The panels contain no chemical binders or formaldehyde, supporting safer indoor air quality.



### FLAME RETARDANT

Panels rated Class B-s1, d0 according to EN 13501-1, offering high fire safety performance for walls and ceilings.



### MAINTENANCE

Panels can be cleaned easily using a dust broom, vacuum cleaner, or a damp cloth.



## SOUND ABSORPTION

### POLYSOUND ENGRAVE PANELS 12 mm

Sound class D ( $\alpha_w=0.37$ ) [according to ISO 354:2003 & ISO 11654:1997]

### POLYSOUND ENGRAVE PANELS 24 mm

Sound class C ( $\alpha_w=0.54$ ) [according to ISO 354:2003 & ISO 11654:1997]

Absorption coefficient measurements

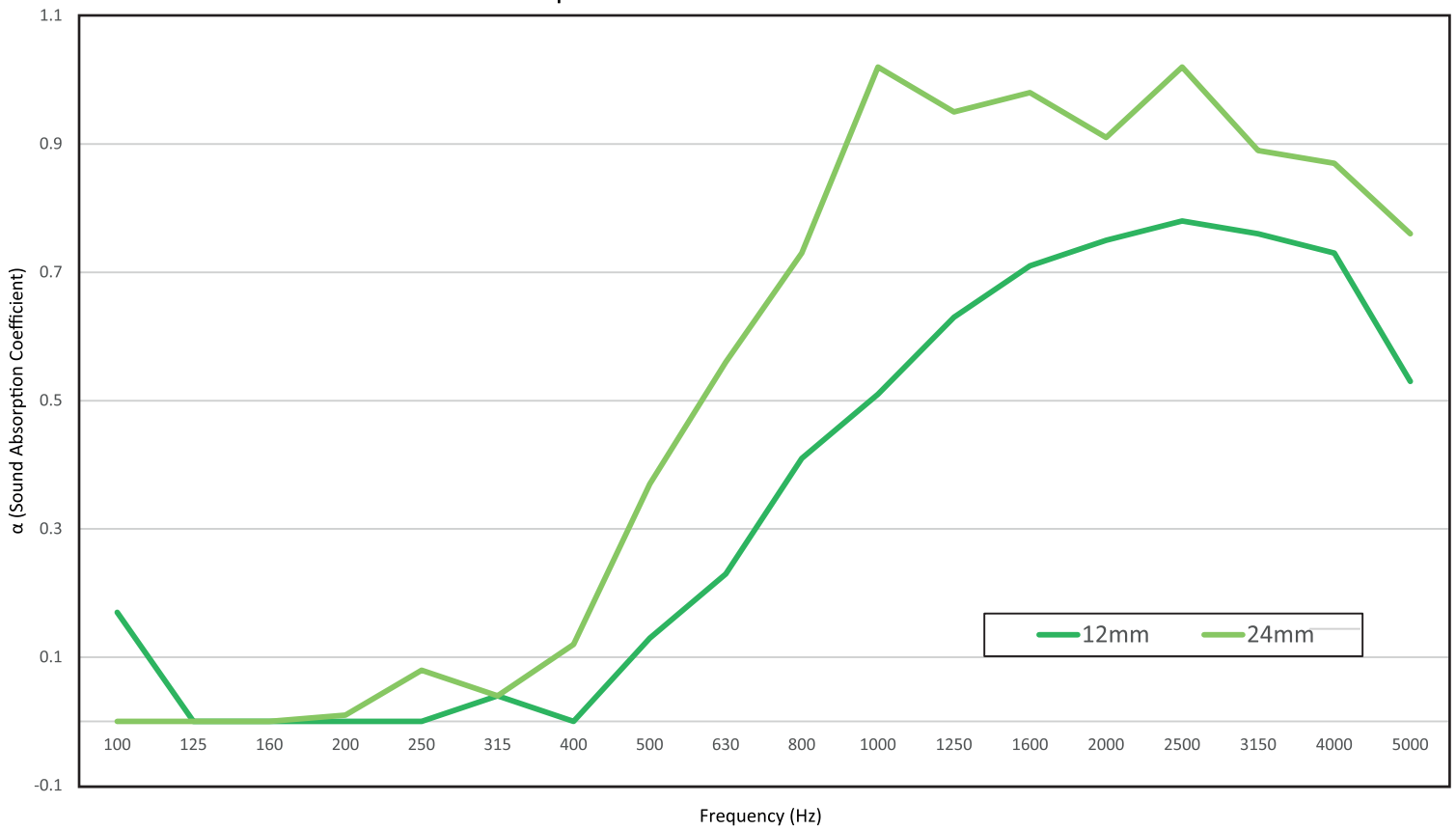

Frequency (Hz)	100	125	160	200	250	315	400	500	630	800	1000	1250	1600	2000	2500	3150	4000	5000
<b>as</b> 12 mm	0.17	0	0	0	0	0.04	0	0.13	0.23	0.41	0.51	0.63	0.71	0.75	0.78	0.76	0.73	0.53
	0.06			0.01			0.12			0.52			0.75			0.67		
<b>as</b> 24 mm	0	0	0	0.01	0.08	0.04	0.12	0.37	0.56	0.73	1.02	0.95	0.98	0.91	1.02	0.89	0.87	0.76
	0.00			0.04			0.35			0.90			0.97			0.84		

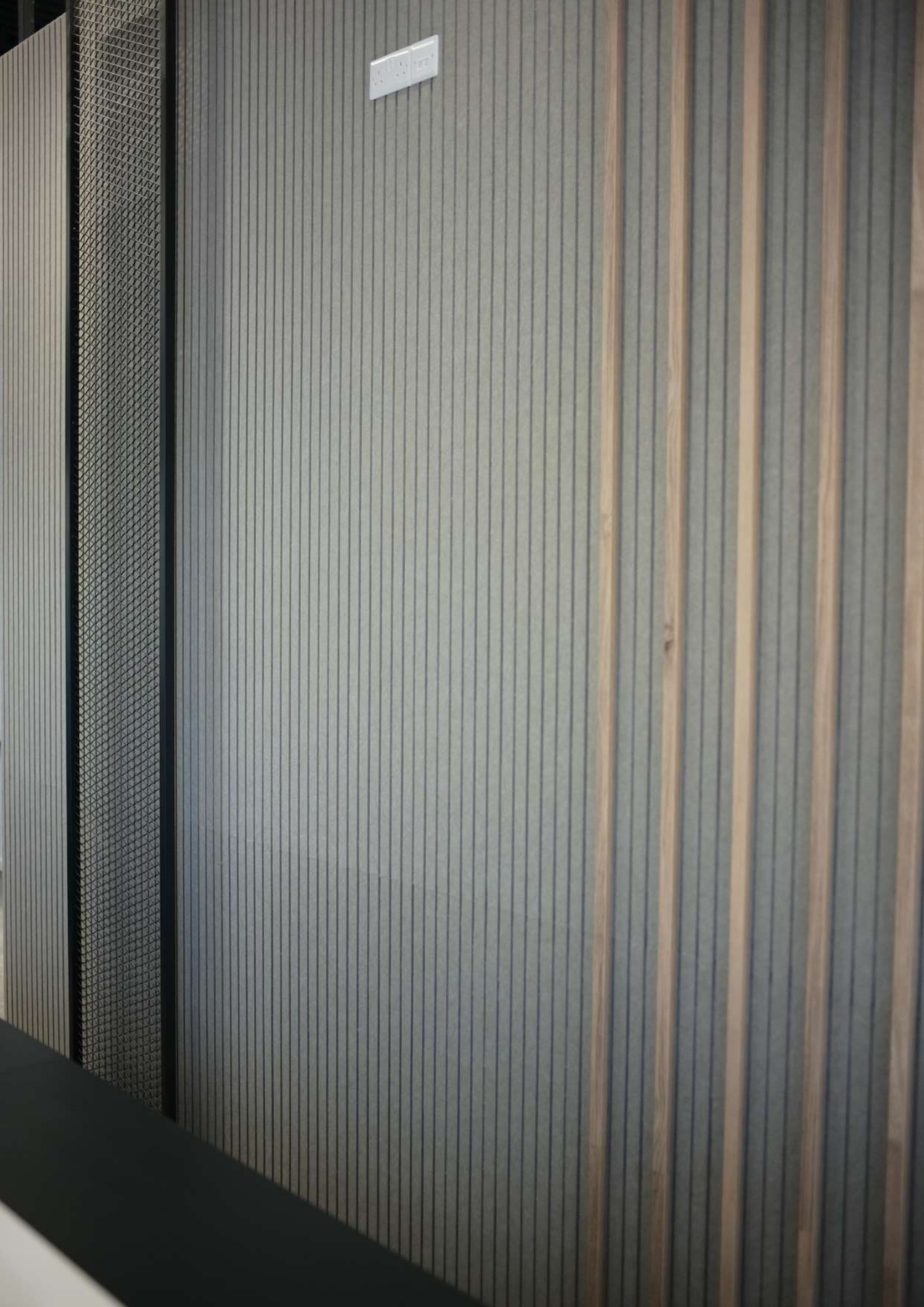

## STANDARD DIMENSIONS AND TYPES

**30-10:**  
3 cm solid – 1 cm engrave

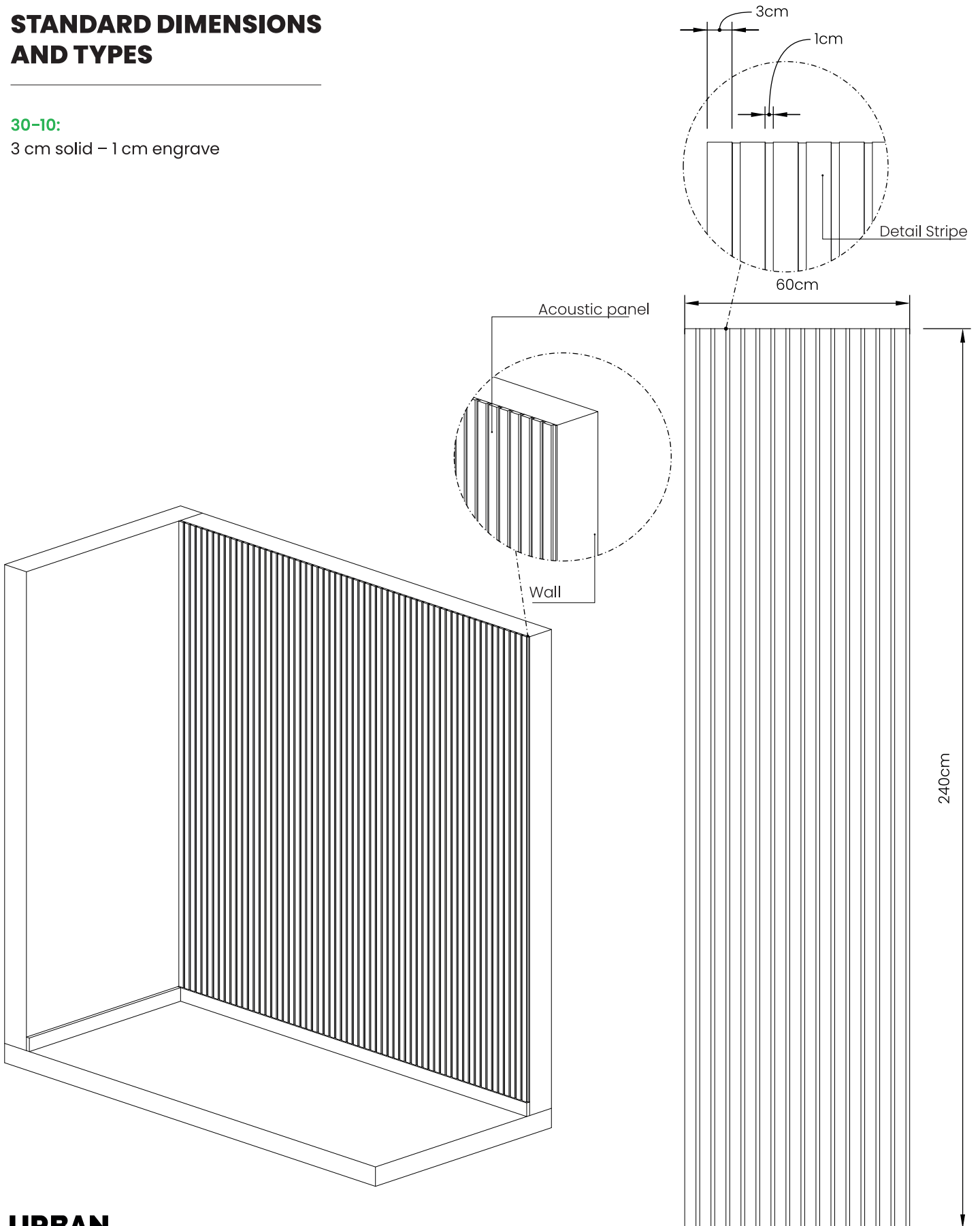

---

**STANDARD DIMENSIONS  
AND TYPES**

---

**44-16:**  
4.4 cm solid – 1.6 cm engrave

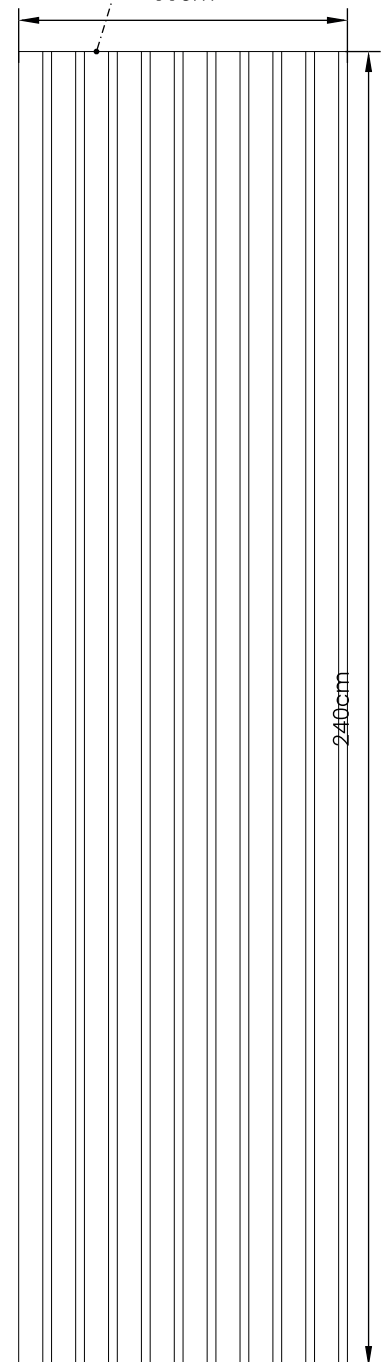
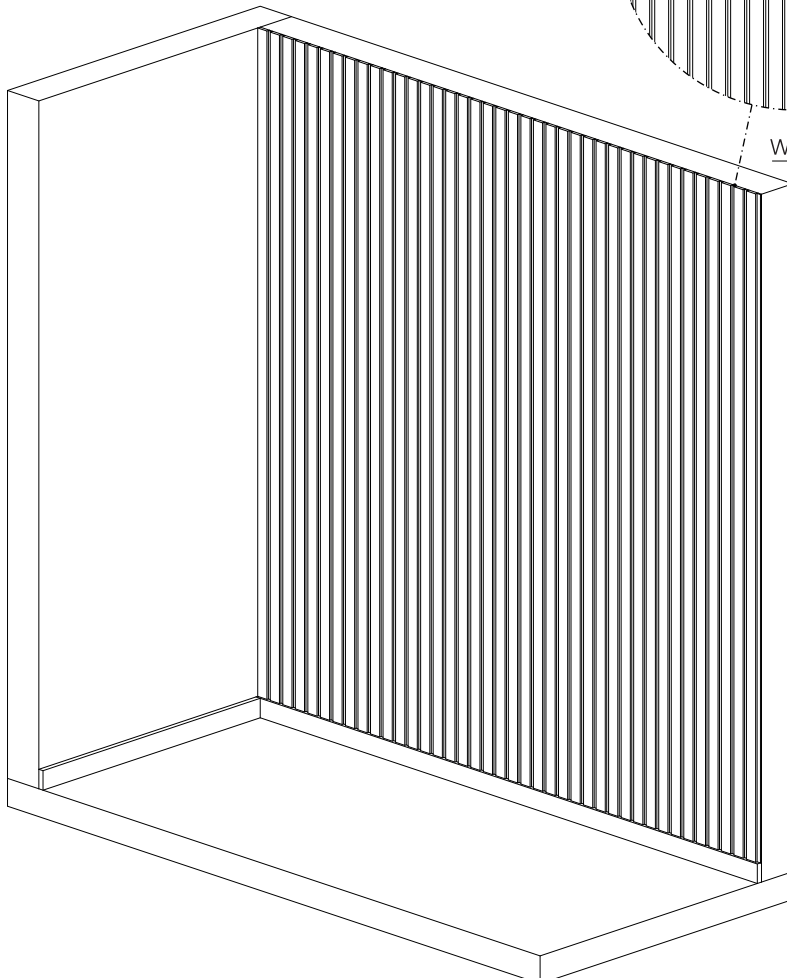
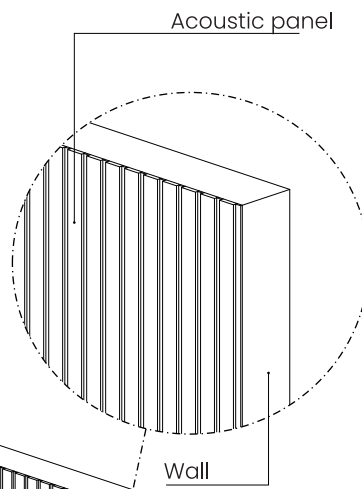
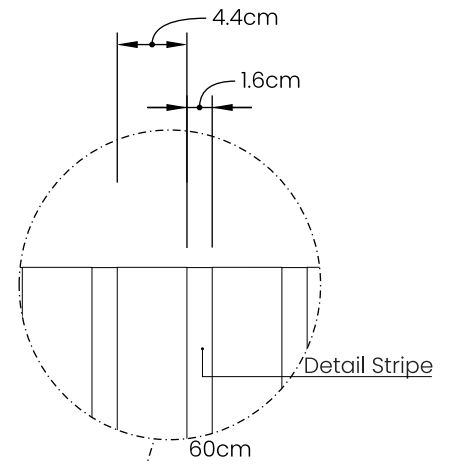

## STANDARD DIMENSIONS AND TYPES

**24-16:**

2.4 cm solid – 1.6 cm engrave

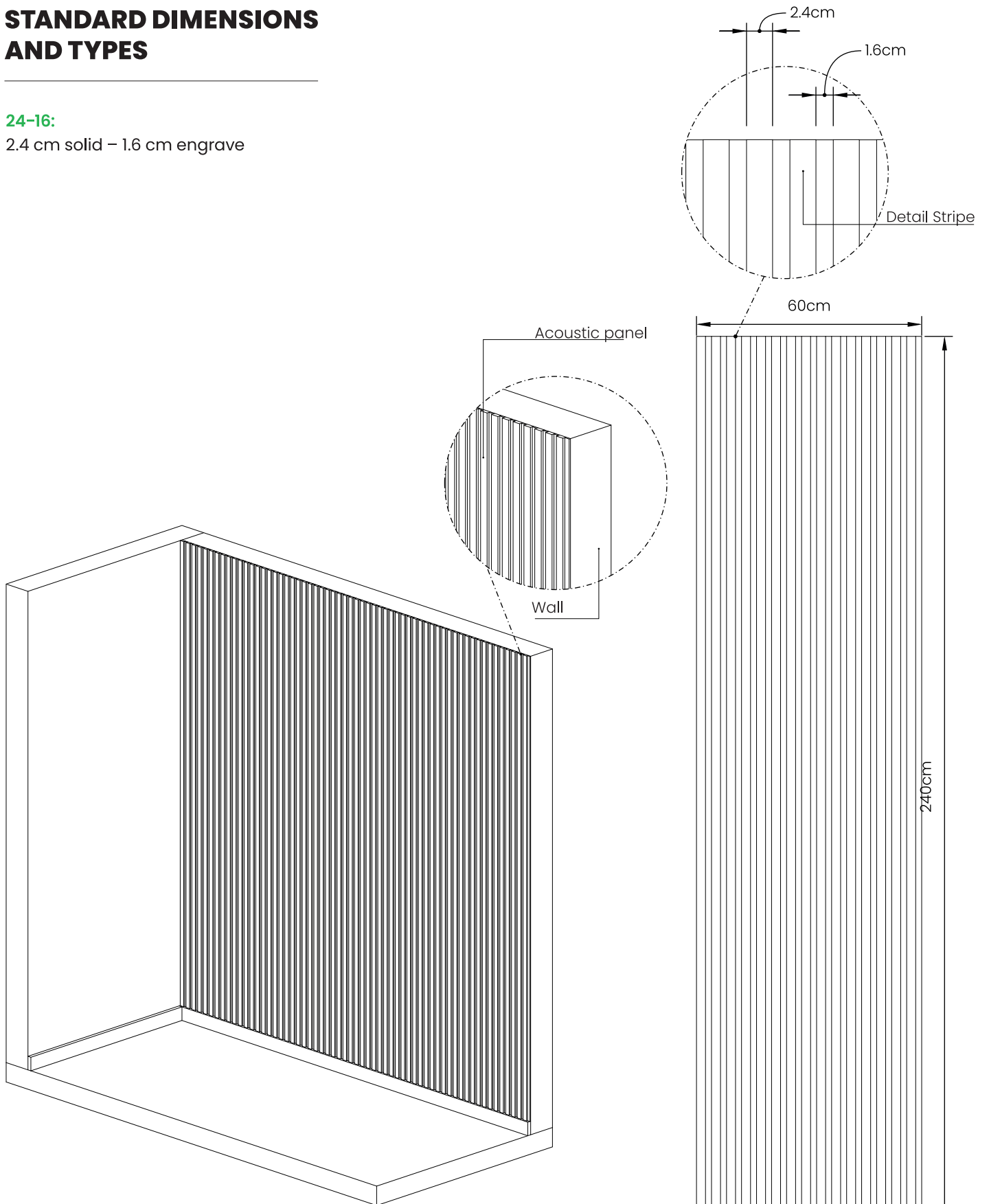

---

**STANDARD DIMENSIONS  
AND TYPES**

---

**100-20:**

10 cm solid – 2 cm engrave

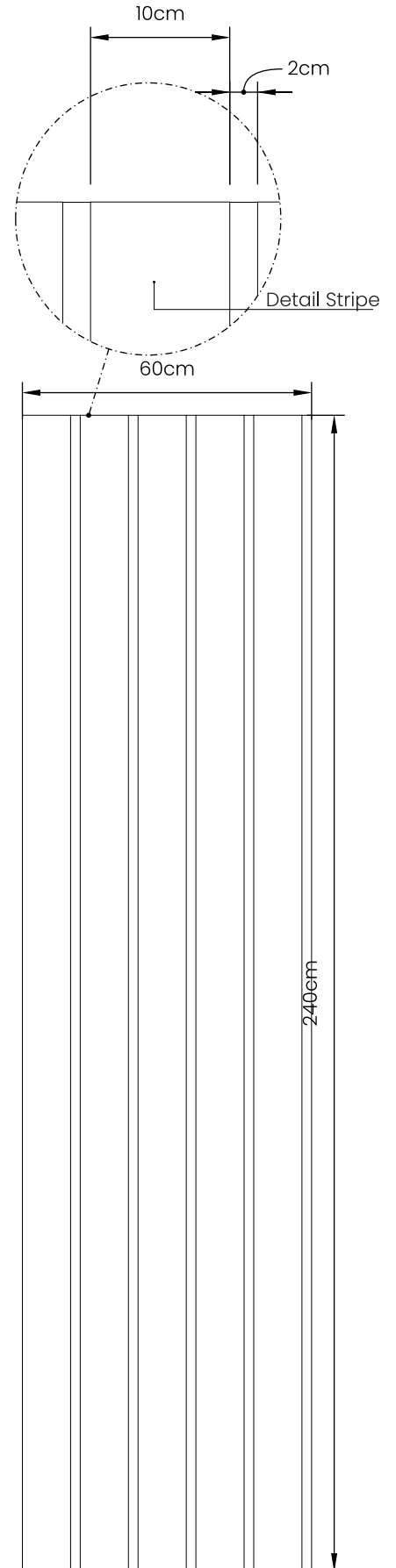
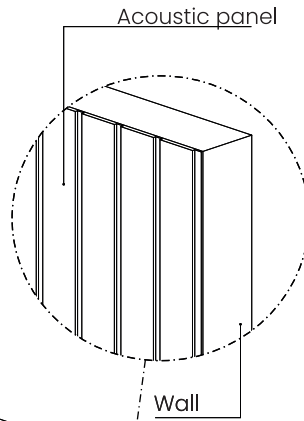
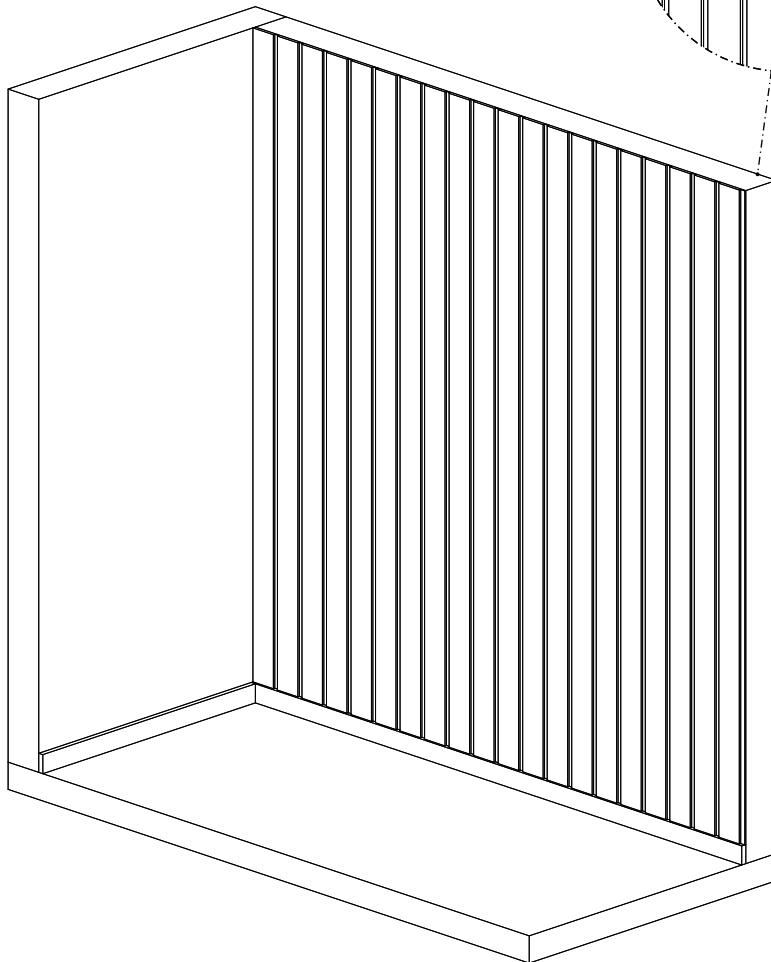

---

**STANDARD DIMENSIONS  
AND TYPES**

---

**190-10:**  
19 cm solid – 1 cm engrave

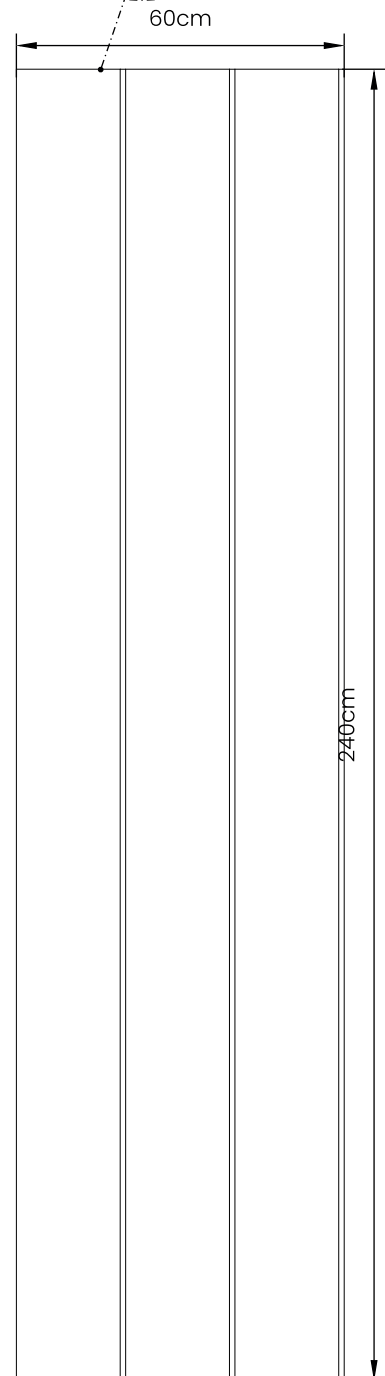
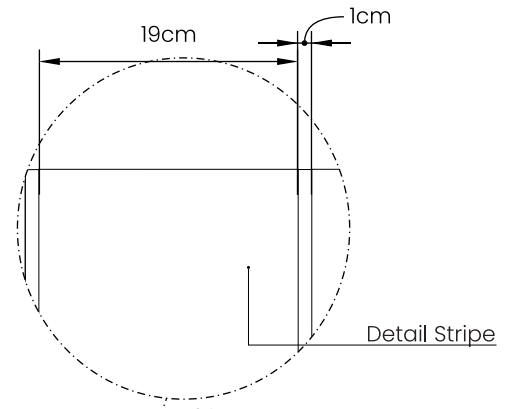
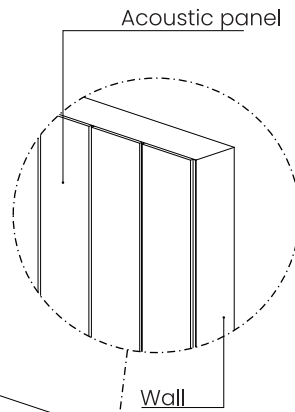
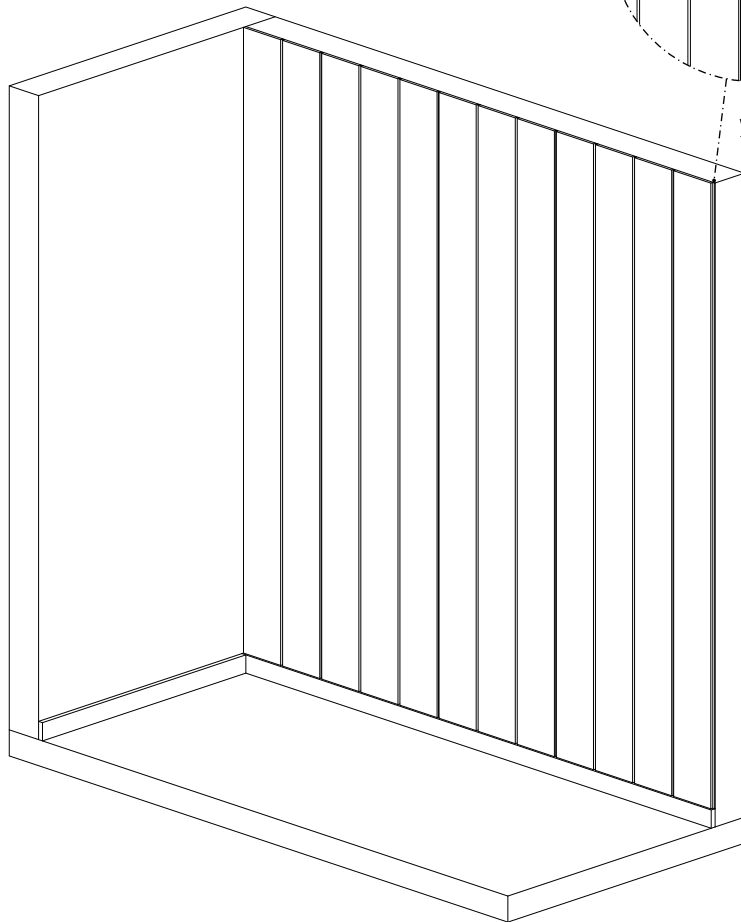





## ABSTRACT TILES

---

A distinctive solution within the POLYSOUND family, these acoustic panels provide effective sound absorption while creating a seamless, continuous finish on walls and ceilings.

Their engraved surface design adds a refined and artistic character, enhancing the visual impact of the space. Available in a wide range of colours, the system offers flexibility for architects, consultants, and clients to achieve the desired aesthetic result.

## AVAILABLE SIZES

### TILES

59 x 59 cm

### THICKNESS

24 mm

### TYPES

Positive or Negative

## MATERIALS AND COLORS

### MATERIALS

Polyester Fiber: 100% made from recycled PET.

### COLORS

Refer to Polyester Color Palette at page 179.

## TECHNICAL SPECIFICATIONS



### INSTALLATION

Installation can be carried out by adhesive bonding to walls or ceilings.



### SUSTAINABILITY

Panels manufactured from 100% polyester fibre, containing a minimum of 75% post-consumer recycled PET sourced from recycled plastic bottles.



### NON TOXIC

Tested according to BS EN 717-1 (E0) for formaldehyde emissions. The panels contain no chemical binders or formaldehyde, supporting safer indoor air quality.



### FLAME RETARDANT

Panels rated Class B-s1, d0 according to EN 13501-1, offering high fire safety performance for walls and ceilings.



### MAINTENANCE

Panels can be cleaned easily using a dust broom, vacuum cleaner, or a damp cloth.

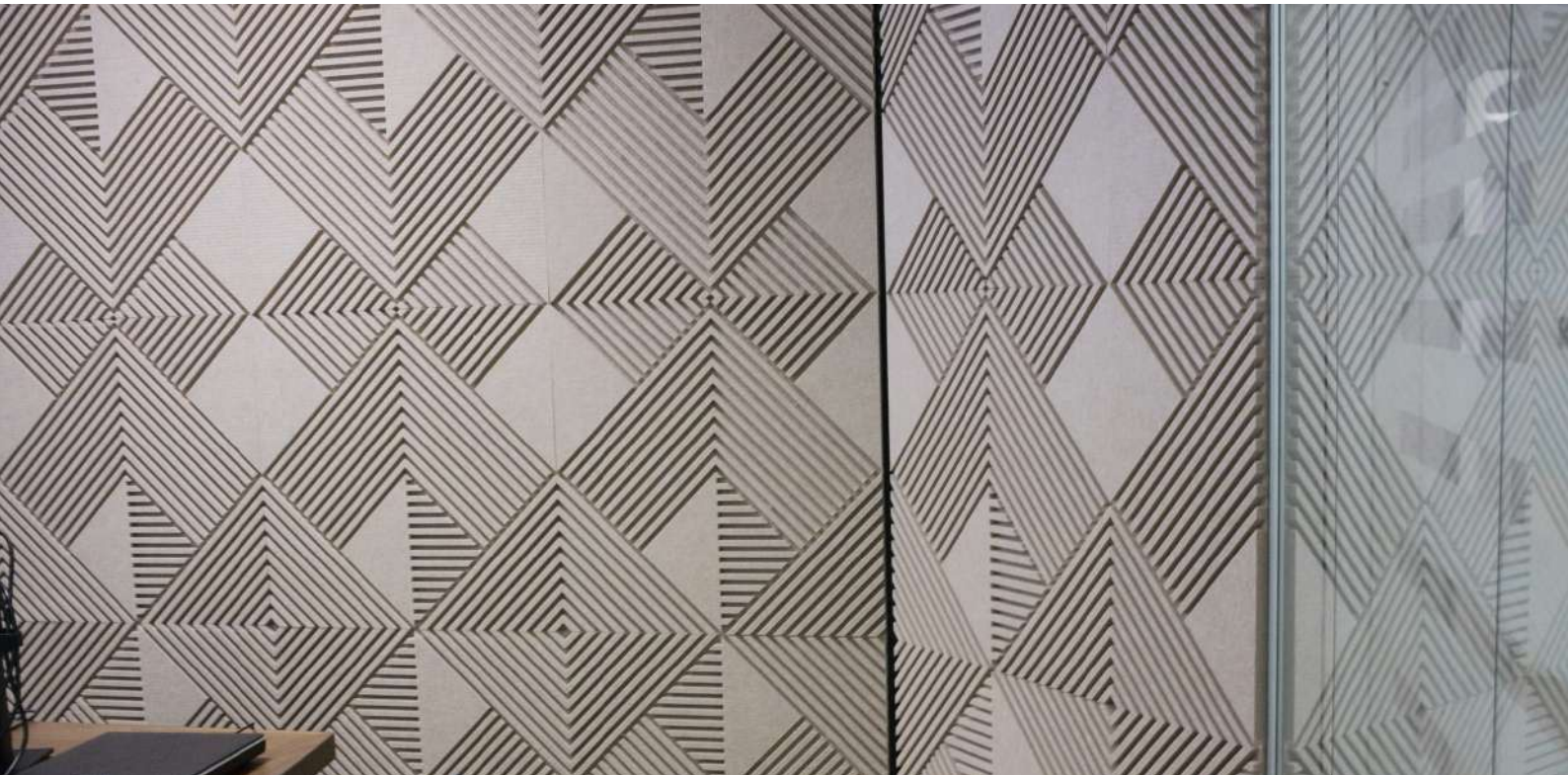

## SOUND ABSORPTION

### POLYSOUND ABSTRACT TILE 24 mm

Sound class D ( $\alpha_w=0.38$ ) [according to ISO 354:2003 & ISO 11654:1997]

Absorption coefficient measurements

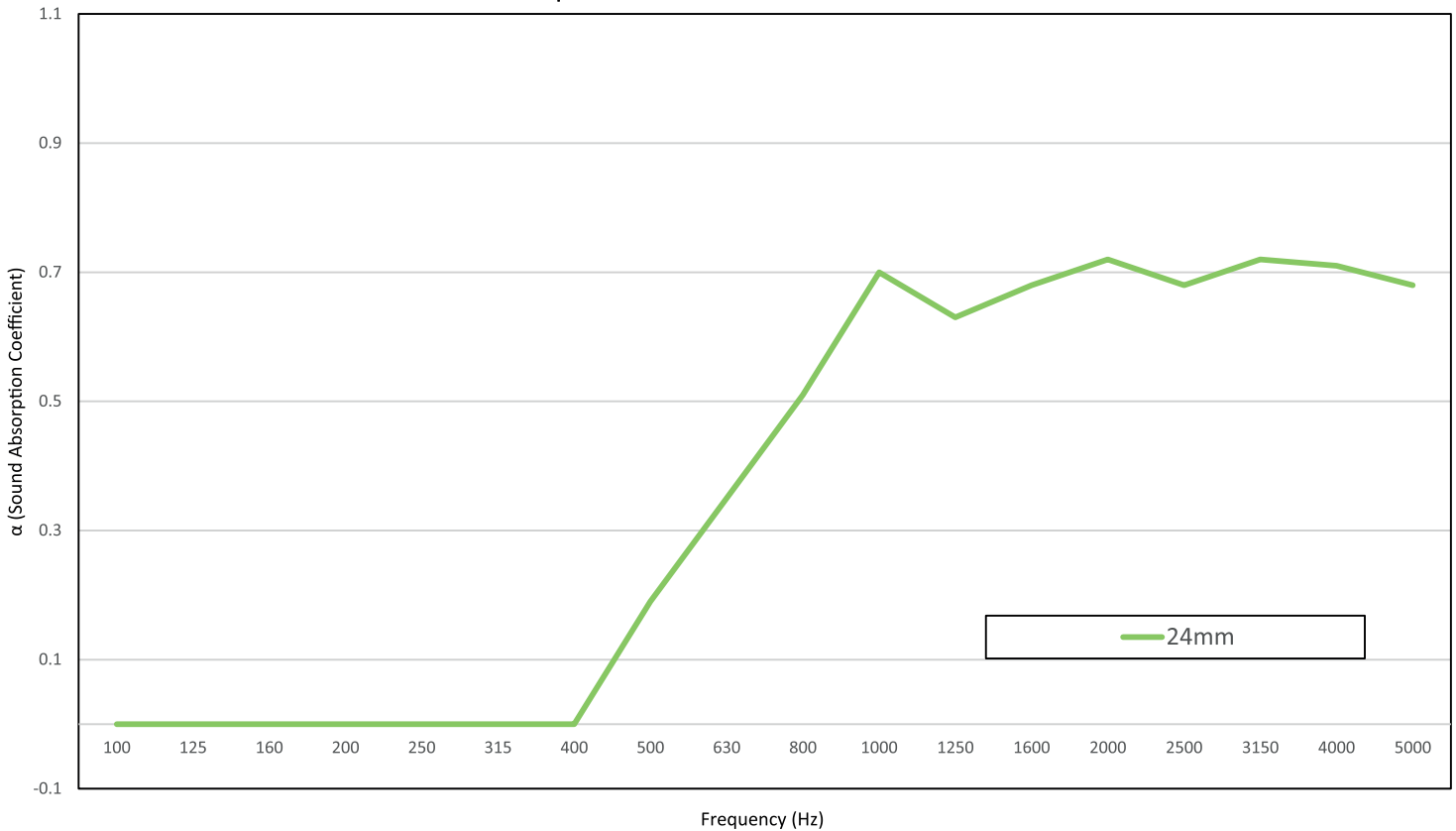

Frequency (Hz)	100	125	160	200	250	315	400	500	630	800	1000	1250	1600	2000	2500	3150	4000	5000
$\alpha_s$ 24 mm	0	0	0	0	0	0	0	0.19	0.35	0.51	0.7	0.63	0.68	0.72	0.68	0.72	0.71	0.68
	0.00			0.00			0.18			0.61			0.69			0.70		



## STANDARD DIMENSIONS AND TYPES

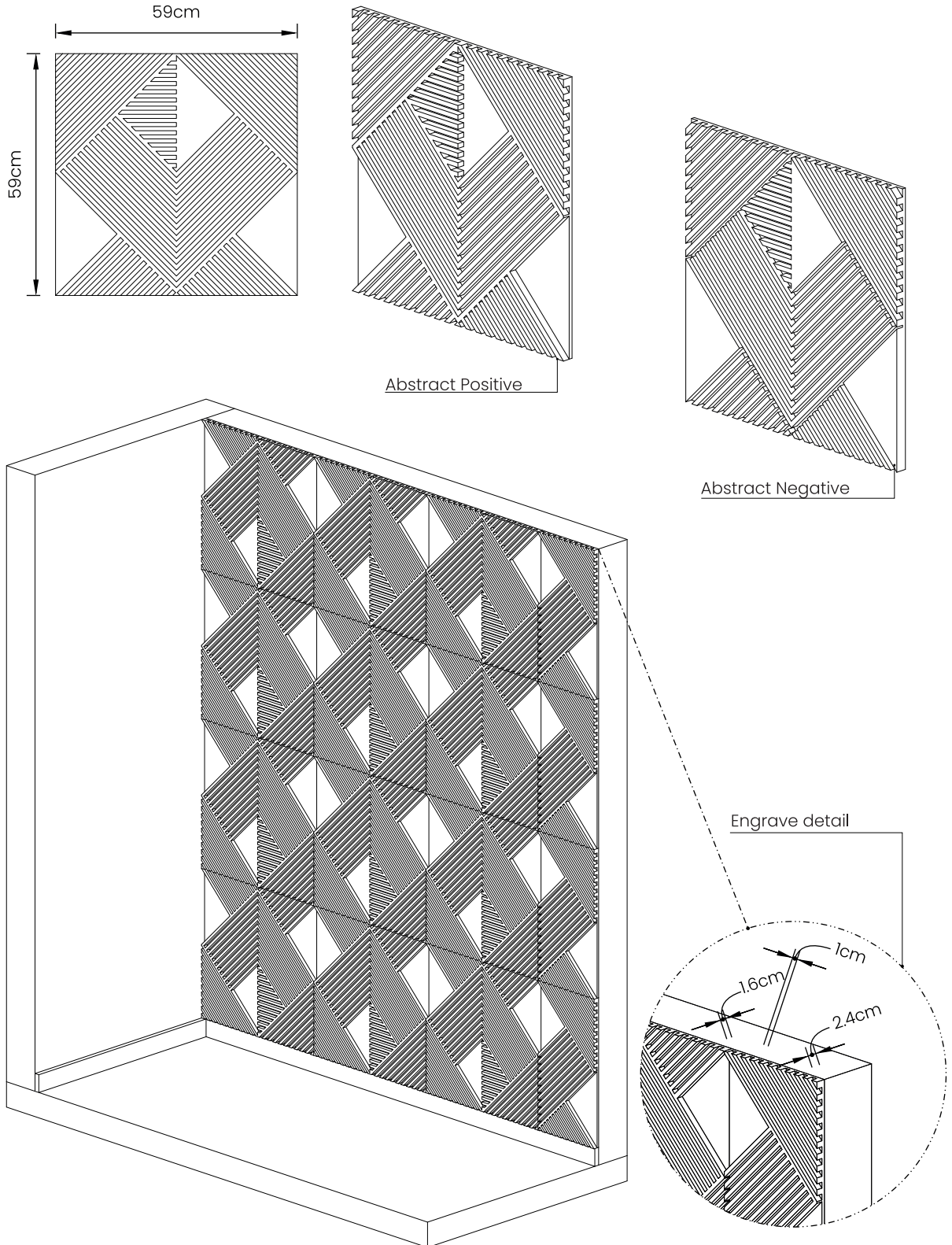





## SOUNDWALL

---

SOUNDWALL is a high-performance acoustic panel system featuring decorative wooden slats designed for installation on walls and ceilings. The system combines effective sound absorption with refined architectural aesthetics, making it suitable for a wide range of residential, commercial, and specialized interior spaces.

Each panel is manufactured as a composite acoustic element, consisting of a 12 mm polyester fiber (PET) acoustic backing combined with 8 mm wooden slats available in MDF, Iroko, or Oak. The panels are supplied as factory pre-assembled units, ensuring consistent quality and easy installation.

Produced in a rectangular modular format, the panels are installed side-by-side to create a continuous, seamless surface on walls or ceilings. SOUNDWALL offers an elegant and visually striking acoustic solution, improving interior acoustics while remaining cost-effective and practical for modern architectural projects.

## AVAILABLE SIZES

### STANDARD PANEL SIZE

240 × 60 cm

### TOTAL THICKNESS

2 cm

### PANEL TYPES

#### TYPE 30-10

Slat Width: 3 cm  
Spacing (slat-to-slat): 1 cm

#### Type 45-15-30

Slat Widths: 4.5 cm & 1.5 cm  
Spacing (slat-to-slat): 1 cm

## MATERIALS AND COLORS

### MATERIALS

Surface Slats: MDF, Iroko, or Oak (8 mm)  
Acoustic Backing: PET acoustic panel (12 mm)

### SOUNDWALL Plus

Additional acoustic backing: 50 mm mineral wool layer for enhanced sound absorption.

### Customization

Panels can be customized in size, finish, and configuration to meet the specific requirements of each project or application.

### COLORS

Refer to Wood Color Palette at page 180.

## TECHNICAL SPECIFICATIONS



### INSTALLATION

Installation can be carried out by mechanical fixing or adhesive bonding to walls or ceilings.



### SUSTAINABILITY

Panels are manufactured from sustainable materials, with PET felt made from recycled plastic and wood sourced from sustainably managed forests.



### NON TOXIC

Wooden slats meet E0 formaldehyde emission standards (desiccator method), ensuring a low-emission and healthier indoor environment.



### FLAME RETARDANT

- Polyester Fiber: Class B-s1, d0 (EN 13501-1)
- Wood: Class B-s2, d0 (EN 13501-1)



### MOISTURE RESISTANCE

The wooden slats offer high moisture resistance due to the melamine resin content, allowing installation in areas such as kitchens and bathrooms when properly finished.

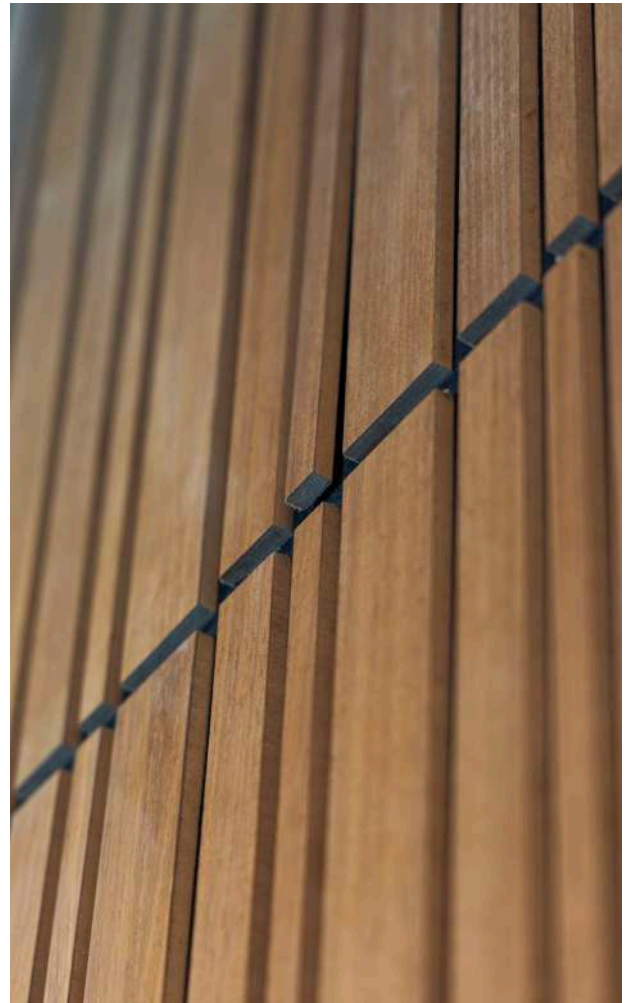

## SOUND ABSORPTION

### SOUNDWALL

Sound class C ( $\alpha_w=0.52$ ) [according to ISO 354:2003 & ISO 11654:1997]  
 (standard total thickness of 20 mm)

### SOUNDWALL PLUS

Sound class B ( $\alpha_w=0.82$ ) [according to ISO 354:2003 & ISO 11654:1997]  
 (with additional backing material of mineral wool 50mm, total thickness 70 mm)

Absorption coefficient measurement

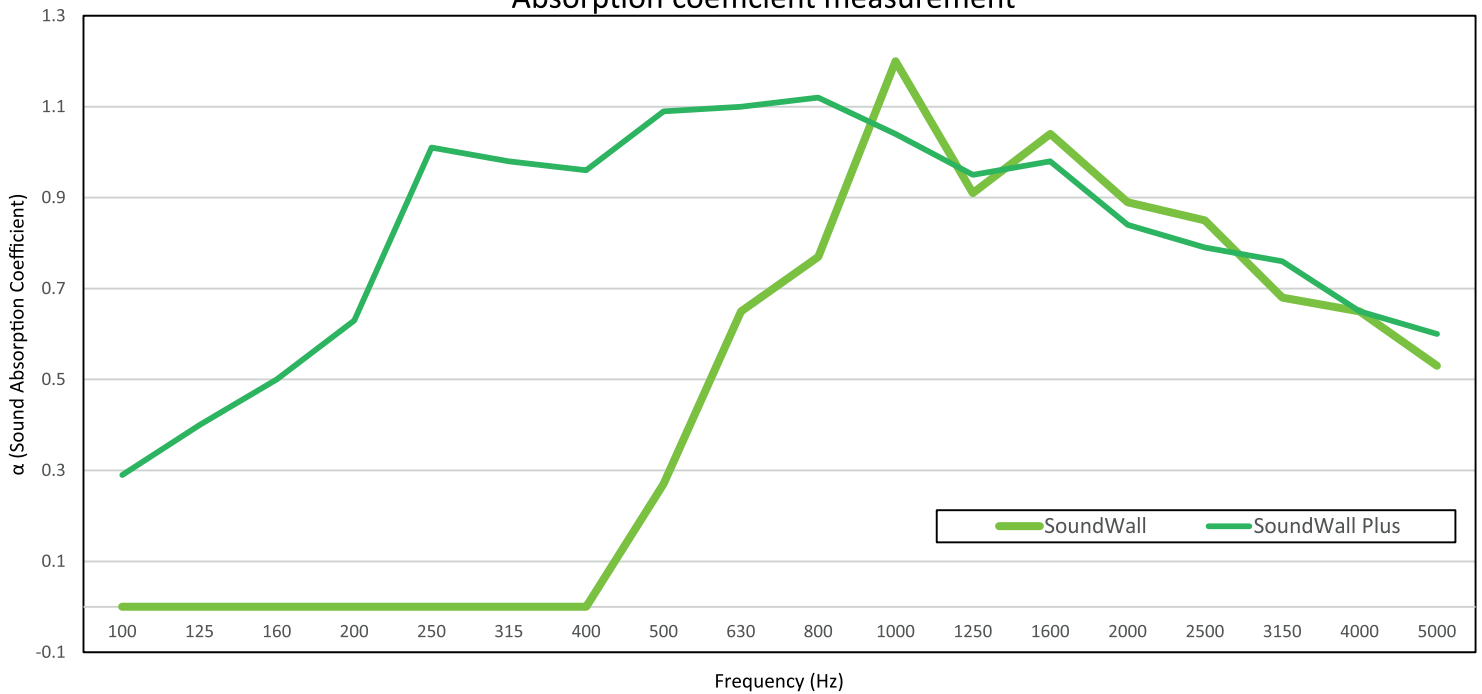

Frequency (Hz)	100	125	160	200	250	315	400	500	630	800	1000	1250	1600	2000	2500	3150	4000	5000
Soundwall	0	0	0	0	0	0	0	0.27	0.65	0.77	1.2	0.91	1.04	0.89	0.85	0.68	0.65	0.53
		0		0			0.31			0.96			0.93			0.62		
Soundwall Plus	0.29	0.4	0.5	0.63	1.01	0.98	0.96	1.09	1.1	1.12	1.04	0.95	0.98	0.84	0.79	0.76	0.65	0.6
		0.4		0.63	0.87		0.96	1.05		1.04			0.98	0.87		0.67		



## STANDARD DIMENSIONS AND TYPES

SOUNDWALL 30-10

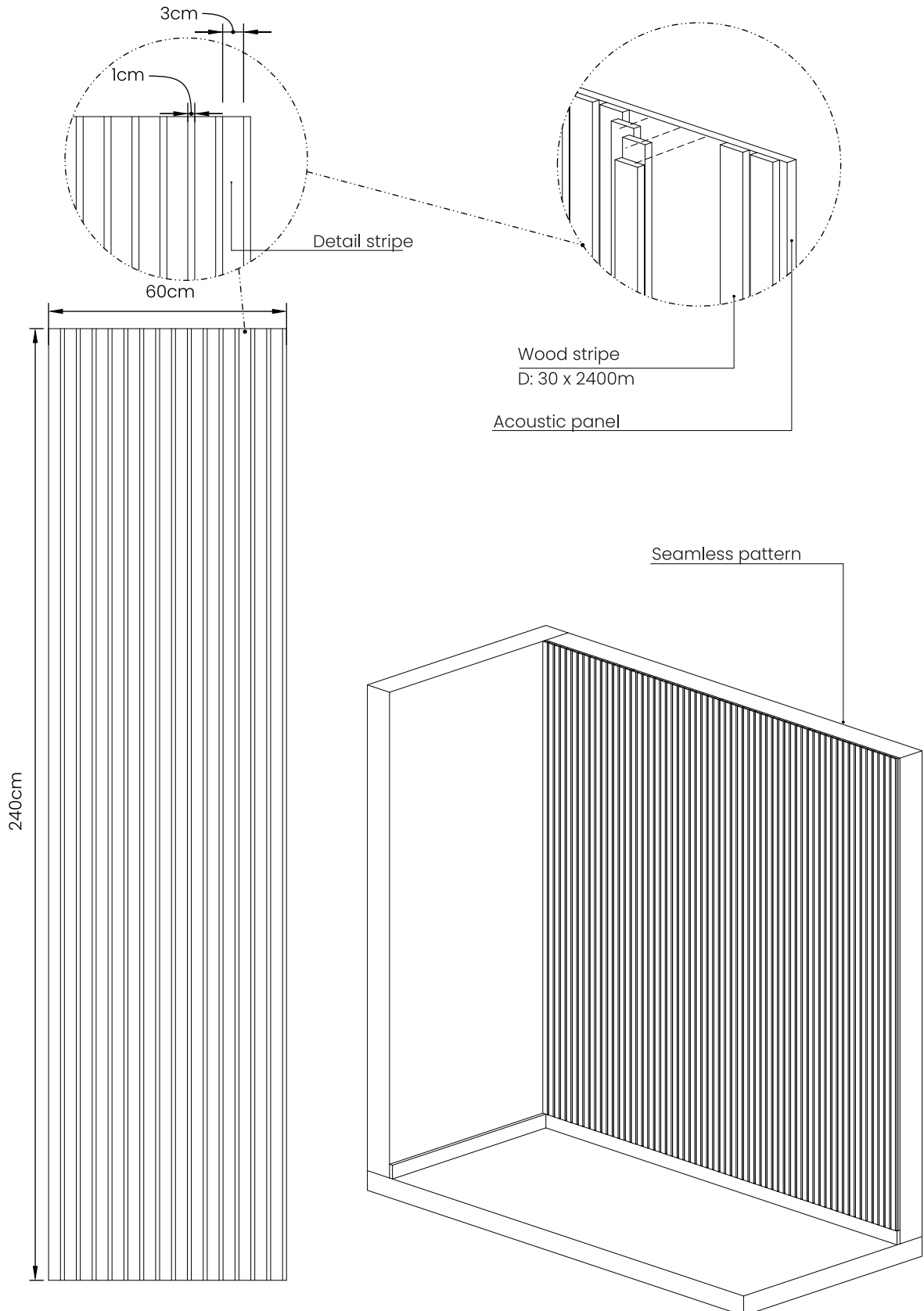

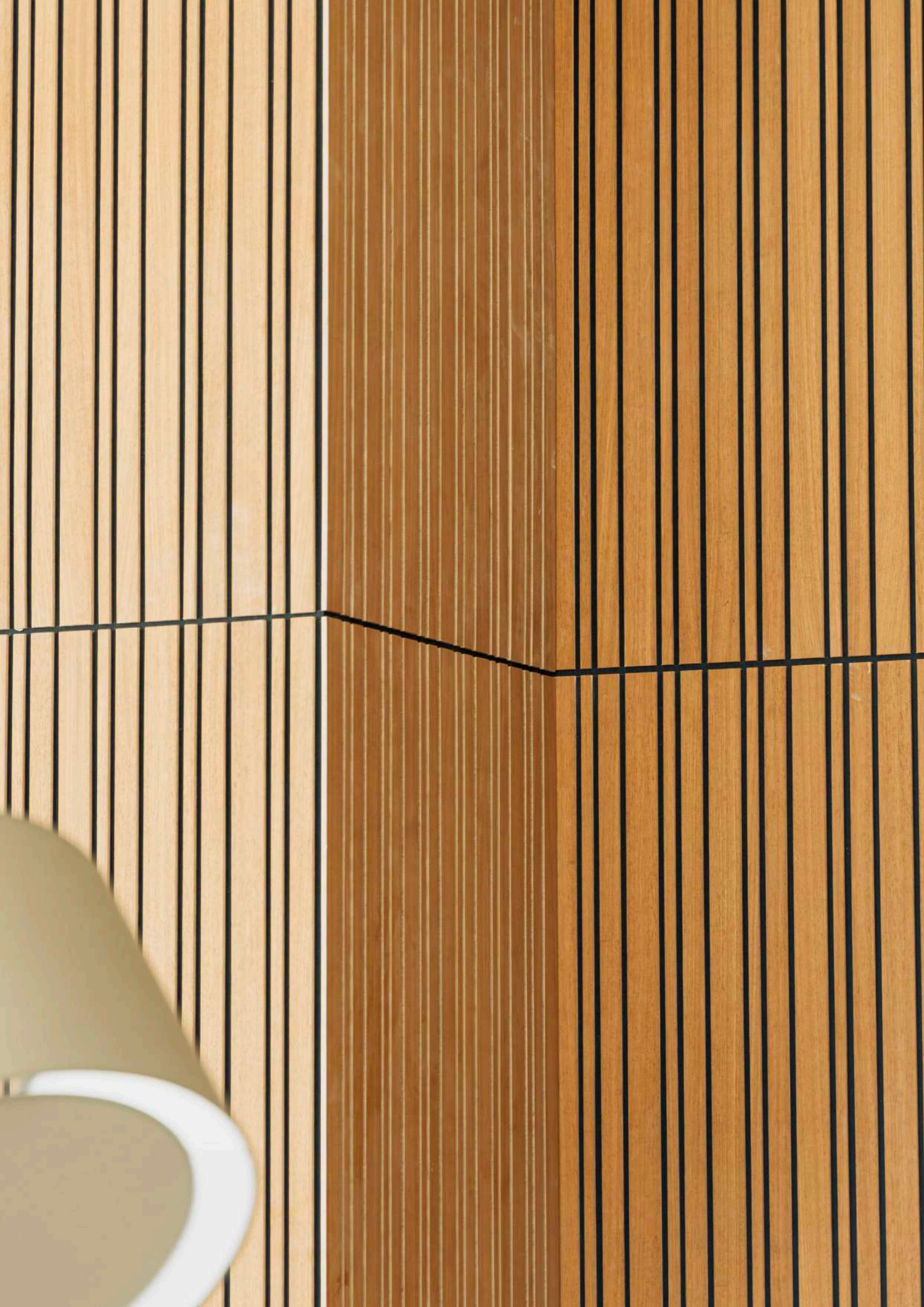

## STANDARD DIMENSIONS AND TYPES

SOUNDWALL 30-15-45

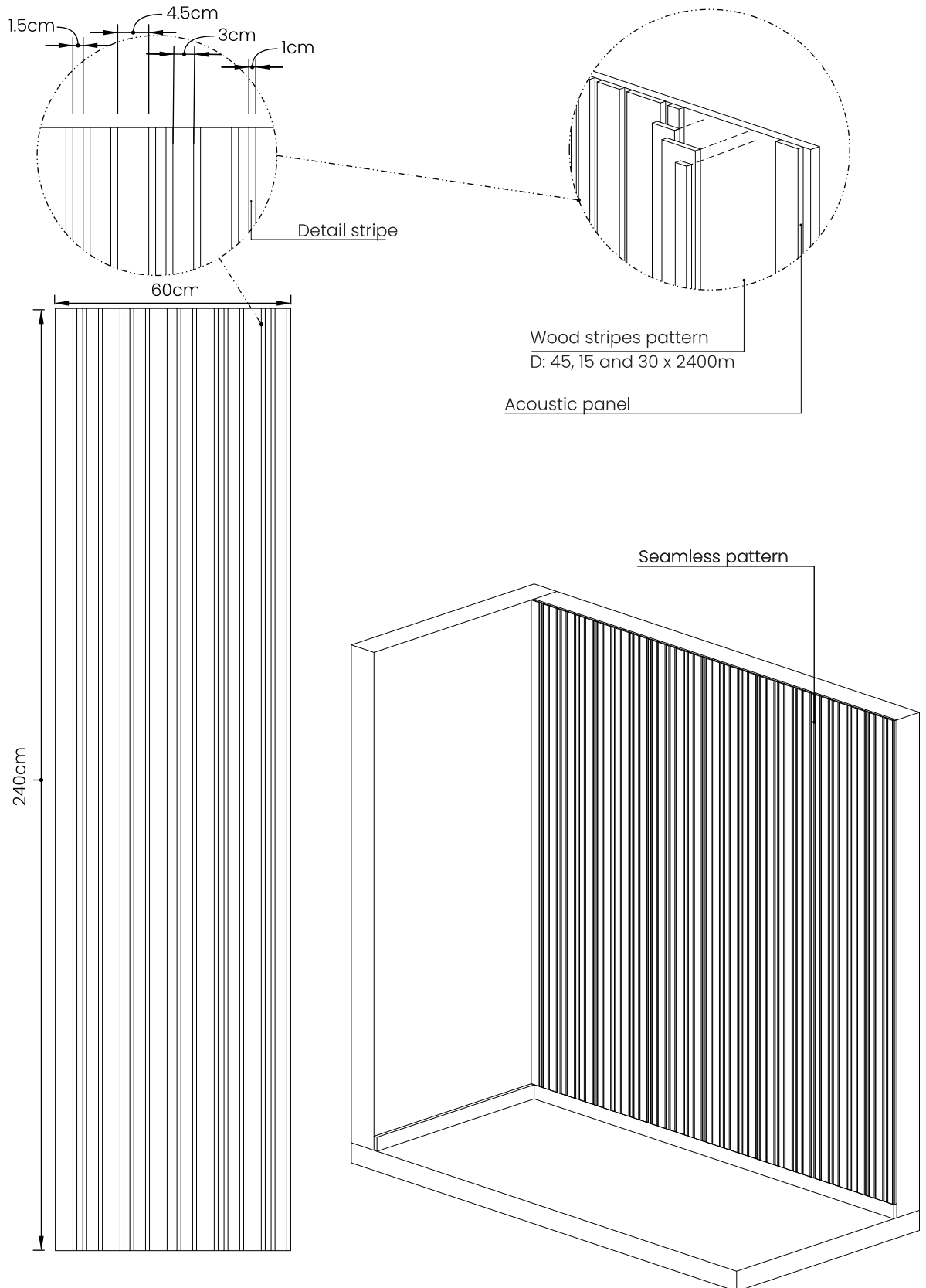



**LINEAR**



**TWISTED**



**WAVY**



**BEAM**

## M-SYSTEM

---

The M-SYSTEM is a lightweight modular ceiling system made from recycled PET acoustic panels, designed to provide effective sound absorption while enhancing interior aesthetics.

Suitable for commercial, private, and specialized spaces, the suspended baffle system helps reduce reverberation and improve acoustic comfort in a wide range of environments.

The system can function as a false ceiling and is installed through mechanical fixing or suspended installation using a metal support structure with steel threaded rods, allowing mounting on walls or ceilings depending on the project requirements.

The system also allows seamless integration of building services such as HVAC systems, lighting fixtures, fire sprinklers, and audio equipment.

Combining acoustic performance, sustainable materials, and modern design, the M-SYSTEM offers a cost-effective and visually striking ceiling solution for contemporary interior projects.

LINEAR



## AVAILABLE SIZES

### MODULE SIZE

193.8 cm x 240 cm

### THICKNESS OF BAFFLES

12 mm or 24 mm

### HEIGHT OF BAFFLES

16 cm

### SUPPORT TYPE

Galvanised steel structure

### HEIGHT OF SYSTEM

17 cm

### HANGED METHOD

Galvanised threaded screw rod

### GAP BETWEEN BAFFLES

4 cm or 9 cm

### HANGED HEIGHT

Flexible (according to needs)

## MATERIALS AND COLORS

### MATERIALS

Polyester Fiber: 100% made from recycled PET.

### COLORS

Refer to Polyester Color Palette at page 179.

## TECHNICAL SPECIFICATIONS



### INSTALLATION

Installation can be carried out by mechanical fixing or suspension using a metal structure, on walls or ceilings.



### SUSTAINABILITY

Panels manufactured from 100% polyester fibre, containing a minimum of 75% post-consumer recycled PET sourced from recycled plastic bottles.



### NON TOXIC

Tested according to BS EN 717-1 (E0) for formaldehyde emissions. The panels contain no chemical binders or formaldehyde, supporting safer indoor air quality.



### FLAME RETARDANT

Panels rated Class B-s1, d0 according to EN 13501-1, offering high fire safety performance for walls and ceilings.



### MAINTENANCE

Panels can be cleaned easily using a dust broom, vacuum cleaner, or a damp cloth.



## SOUND ABSORPTION

### M-SYSTEM LINEAR - 4 cm GAP - MATERIAL 12 mm

Sound class D ( $\alpha_w=0.30$ ) [according to ISO 354:2003 & ISO 11654:1997]

### M-SYSTEM LINEAR - 4 cm GAP - MATERIAL 24 mm

Sound class C ( $\alpha_w=0.61$ ) [according to ISO 354:2003 & ISO 11654:1997]

Absorption coefficient measurements

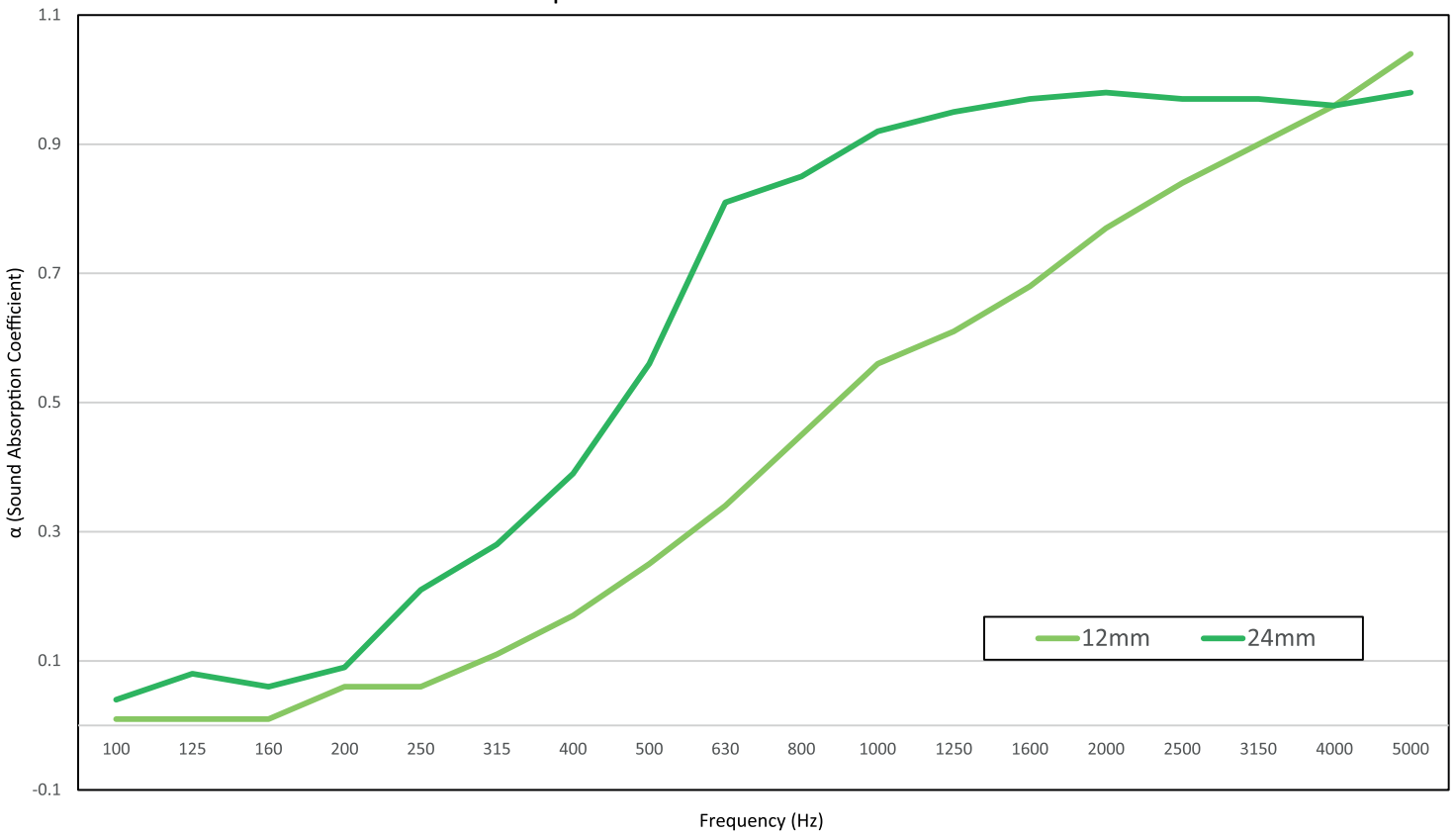

Frequency (Hz)	100	125	160	200	250	315	400	500	630	800	1000	1250	1600	2000	2500	3150	4000	5000
<b>as</b> <b>12 mm</b>	0.01	0.01	0.01	0.06	0.06	0.11	0.17	0.25	0.34	0.45	0.56	0.61	0.68	0.77	0.84	0.9	0.96	1.04
		0.01			0.08			0.25			0.54			0.76			0.97	
<b>as</b> <b>24 mm</b>	0.04	0.08	0.06	0.09	0.21	0.28	0.39	0.56	0.81	0.85	0.92	0.95	0.97	0.98	0.97	0.97	0.96	0.98
		0.06			0.19			0.59			0.91			0.97			0.97	

## SOUND ABSORPTION

### M-SYSTEM LINEAR – 9 cm GAP – 12 mm – TYPE J MOUNTING

Sound class C ( $\alpha_w=0.56$ ) [according to ISO 354:2003]

### M-SYSTEM LINEAR – 9 cm GAP – 24 mm – TYPE J MOUNTING

Sound class C ( $\alpha_w=0.62$ ) [according to ISO 354:2003]

Absorption coefficient measurements

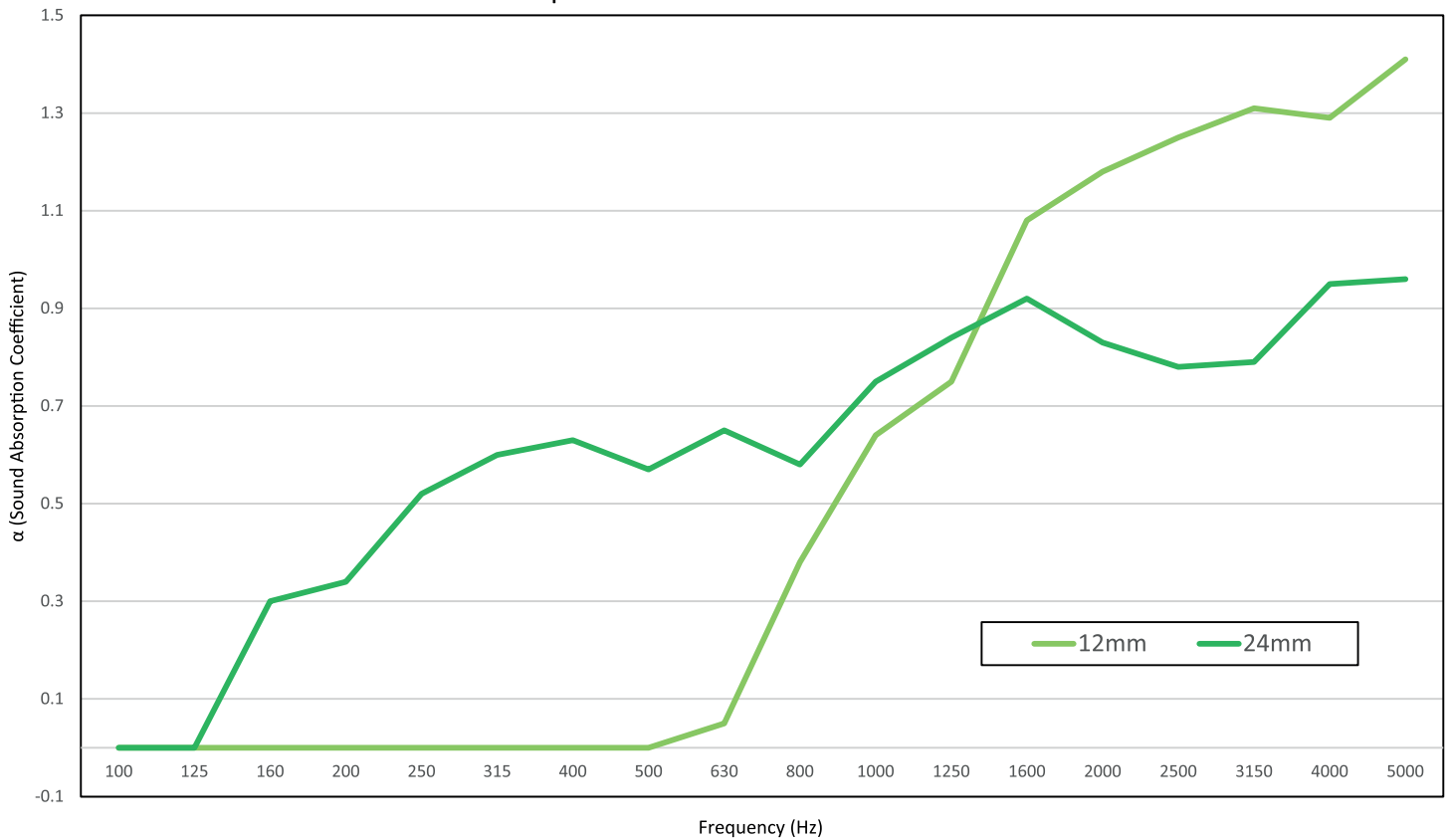

Frequency (Hz)	100	125	160	200	250	315	400	500	630	800	1000	1250	1600	2000	2500	3150	4000	5000
<b><math>\alpha_s</math></b>	0	0	0	0	0	0	0	0	0.05	0.38	0.64	0.75	1.08	1.18	1.25	1.31	1.29	1.41
<b>12 mm</b>	0.00			0.00			0.02			0.59			1.17			1.34		
<b><math>\alpha_s</math></b>	0	0	0.3	0.34	0.52	0.6	0.63	0.57	0.65	0.58	0.75	0.84	0.92	0.83	0.78	0.79	0.95	0.96
<b>24 mm</b>	0.10			0.49			0.62			0.72			0.84			0.90		



## STANDARD DIMENSIONS AND TYPES

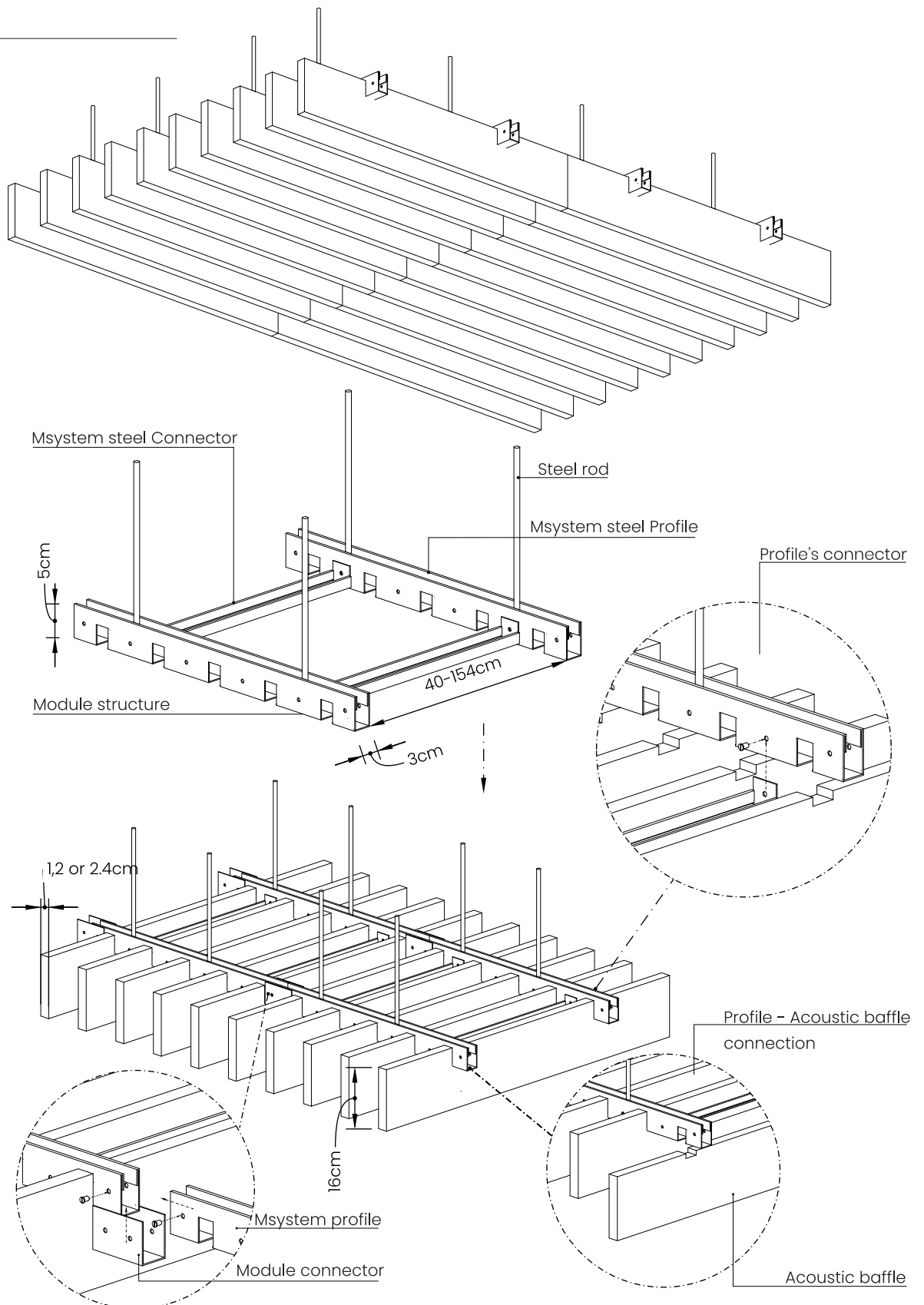



## STANDARD DIMENSIONS AND TYPES

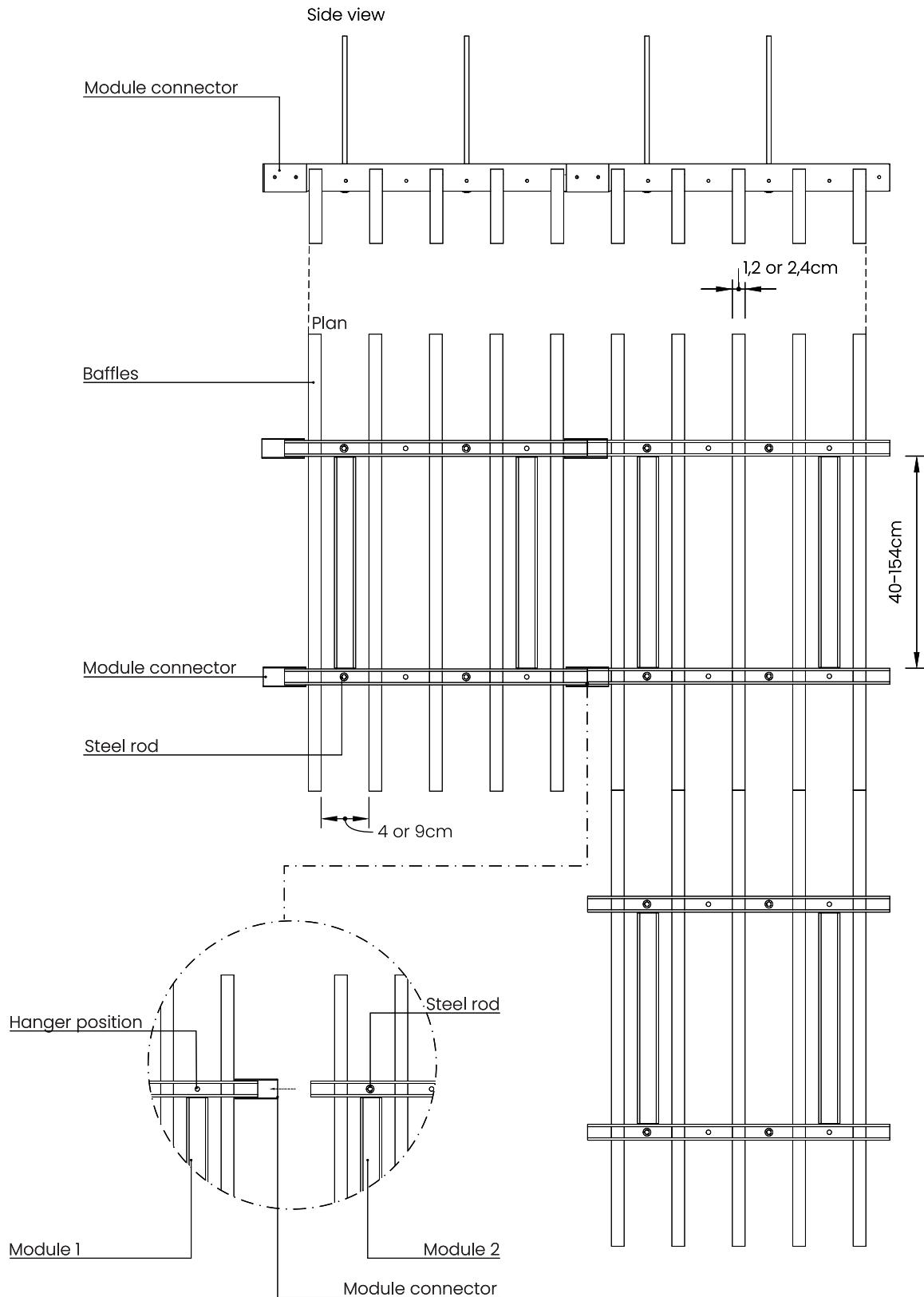

**TWISTED**



## AVAILABLE SIZES

**MODULE SIZE**

193.8 cm x 240 cm

**HEIGHT OF BAFFLES**

16 cm

**HEIGHT OF SYSTEM**

17 cm

**GAP BETWEEN BAFFLES**

4 cm or 9 cm

**THICKNESS OF BAFFLES**

12 mm or 24 mm

**SUPPORT TYPE**

Galvanised steel structure

**HANGED METHOD**

Galvanised threaded screw rod

**HANGED HEIGHT**

Flexible (according to needs)

## TECHNICAL SPECIFICATIONS



**INSTALLATION**

Installation can be carried out by mechanical fixing or suspension using a metal structure, on walls or ceilings.



**SUSTAINABILITY**

Panels manufactured from 100% polyester fibre, containing a minimum of 75% post-consumer recycled PET sourced from recycled plastic bottles.



**NON TOXIC**

Tested according to BS EN 717-1 (E0) for formaldehyde emissions. The panels contain no chemical binders or formaldehyde, supporting safer indoor air quality.



**FLAME RETARDANT**

Panels rated Class B-s1, d0 according to EN 13501-1, offering high fire safety performance for walls and ceilings.



**MAINTENANCE**

Panels can be cleaned easily using a dust broom, vacuum cleaner, or a damp cloth.

## MATERIALS AND COLORS

**MATERIALS**

Polyester Fiber: 100% made from recycled PET

**COLORS**

Refer to Polyester Color Palette at page 179.



## SOUND ABSORPTION

### M-SYSTEM TWISTED - 4 cm GAP - MATERIAL 12 mm

Sound class D ( $\alpha_w=0.30$ ) [according to ISO 354:2003 & ISO 11654:1997]

### M-SYSTEM TWISTED - 4 cm GAP - MATERIAL 24 mm

Sound class C ( $\alpha_w=0.61$ ) [according to ISO 354:2003 & ISO 11654:1997]

Absorption coefficient measurements

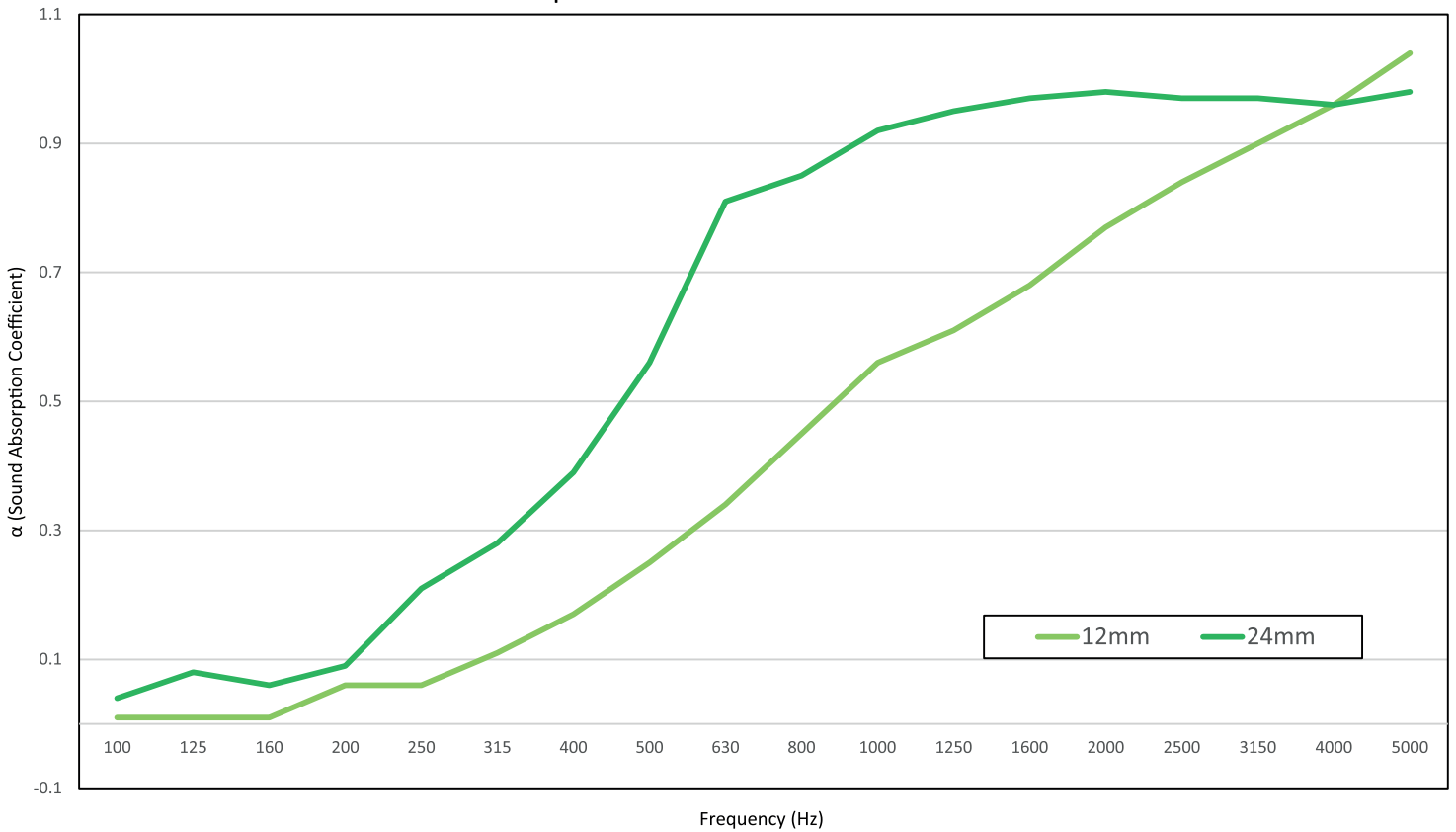

Frequency (Hz)	100	125	160	200	250	315	400	500	630	800	1000	1250	1600	2000	2500	3150	4000	5000
<b>α<sub>s</sub></b> <b>12 mm</b>	0.01	0.01	0.01	0.06	0.06	0.11	0.17	0.25	0.34	0.45	0.56	0.61	0.68	0.77	0.84	0.9	0.96	1.04
	0.01			0.08			0.25			0.54			0.76			0.97		
<b>α<sub>s</sub></b> <b>24 mm</b>	0.04	0.08	0.06	0.09	0.21	0.28	0.39	0.56	0.81	0.85	0.92	0.95	0.97	0.98	0.97	0.97	0.96	0.98
	0.06			0.19			0.59			0.91			0.97			0.97		

## SOUND ABSORPTION

### M-SYSTEM TWISTED - 9 cm GAP - 12 mm - TYPE J MOUNTING

Sound class C ( $\alpha_w=0.56$ ) [according to ISO 354:2003]

### M-SYSTEM TWISTED - 9 cm GAP - 24 mm - TYPE J MOUNTING

Sound class C ( $\alpha_w=0.62$ ) [according to ISO 354:2003]

Absorption coefficient measurements

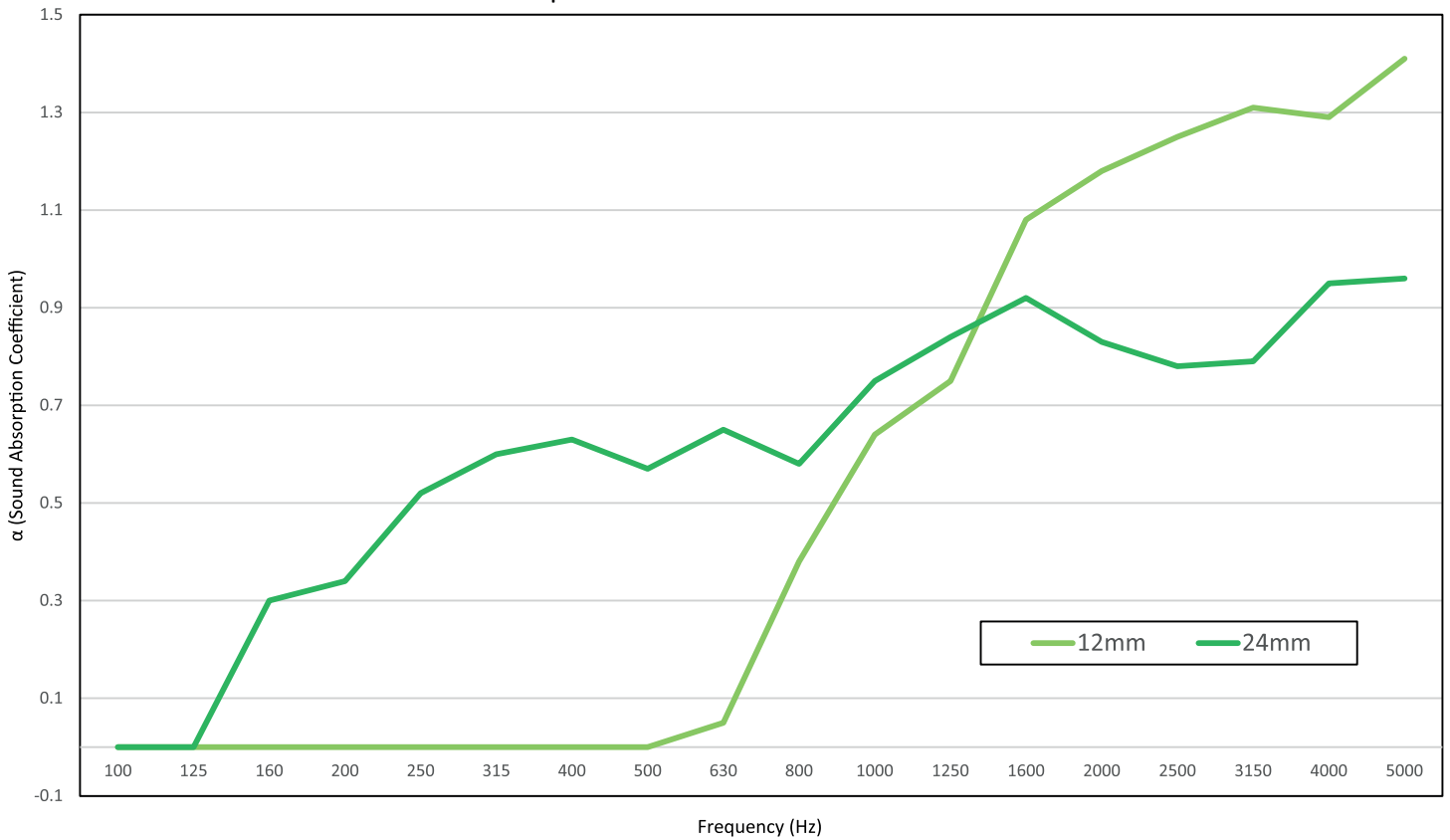

Frequency (Hz)	100	125	160	200	250	315	400	500	630	800	1000	1250	1600	2000	2500	3150	4000	5000
<b><math>\alpha_s</math> 12 mm</b>	0	0	0	0	0	0	0	0	0.05	0.38	0.64	0.75	1.08	1.18	1.25	1.31	1.29	1.41
	0.00			0.00			0.02			0.59			1.17			1.34		
<b><math>\alpha_s</math> 24 mm</b>	0	0	0.3	0.34	0.52	0.6	0.63	0.57	0.65	0.58	0.75	0.84	0.92	0.83	0.78	0.79	0.95	0.96
	0.10			0.49			0.62			0.72			0.84			0.90		



**STANDARD DIMENSIONS  
AND TYPES**

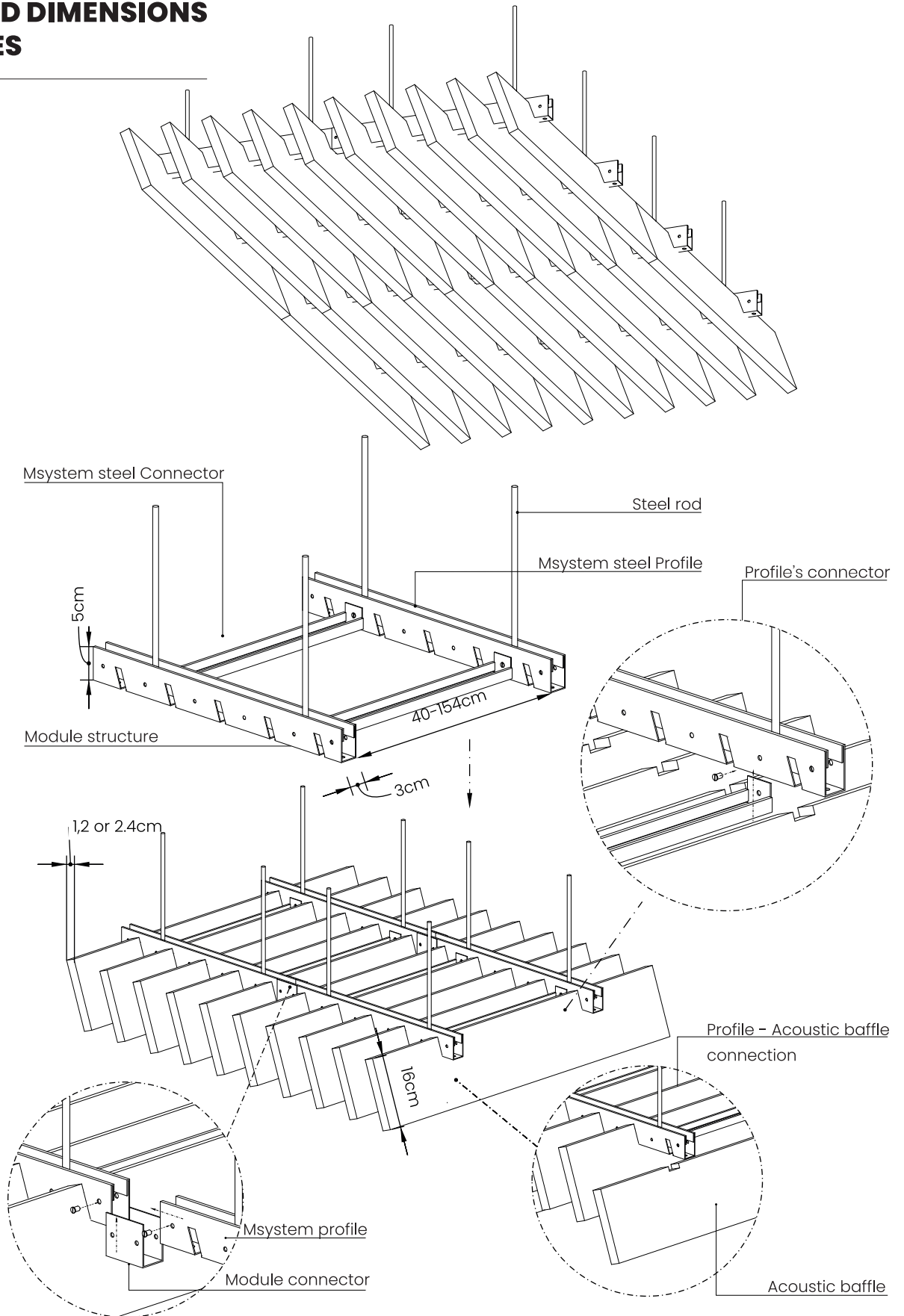



# STANDARD DIMENSIONS AND TYPES

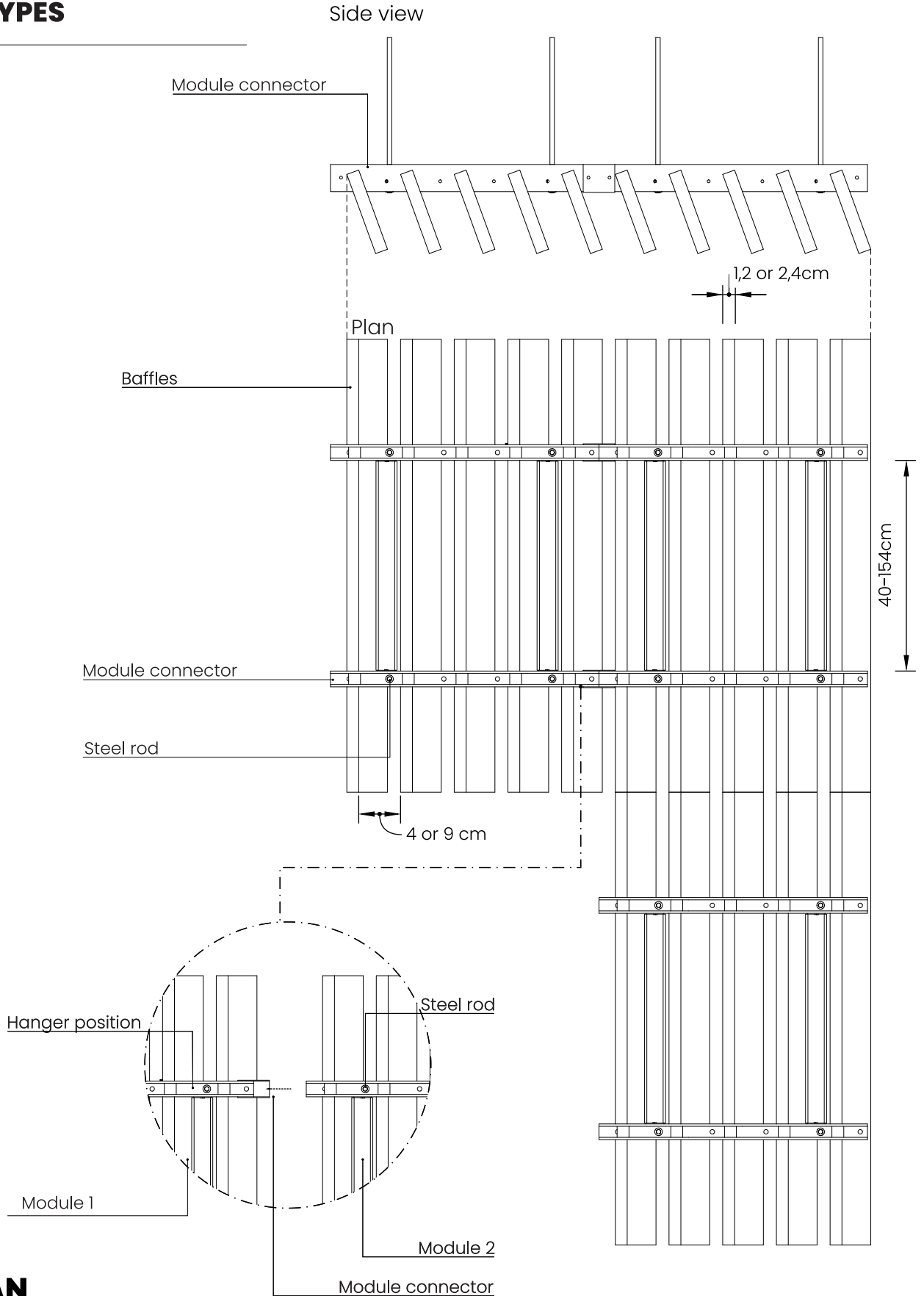

WAVY



## AVAILABLE SIZES

### MODULE SIZE

193.8 cm x 240 cm

### HEIGHT OF BAFFLES

16 cm

### HEIGHT OF SYSTEM

17 cm

### GAP BETWEEN BAFFLES

4 cm or 9 cm

### THICKNESS OF BAFFLES

12 mm or 24 mm

### SUPPORT TYPE

Galvanised steel structure

### HANGED METHOD

Galvanised threaded screw rod

### HANGED HEIGHT

Flexible (according to needs)

## MATERIALS AND COLORS

### MATERIALS

Polyester Fiber: 100% made from recycled PET.

### COLORS

Refer to Polyester Color Palette at page 179.

## TECHNICAL SPECIFICATIONS



### INSTALLATION

Installation can be carried out by mechanical fixing or suspension using a metal structure, on walls or ceilings.



### SUSTAINABILITY

Panels manufactured from 100% polyester fibre, containing a minimum of 75% post-consumer recycled PET sourced from recycled plastic bottles.



### NON TOXIC

Tested according to BS EN 717-1 (E0) for formaldehyde emissions. The panels contain no chemical binders or formaldehyde, supporting safer indoor air quality.



### FLAME RETARDANT

Panels rated Class B-s1, d0 according to EN 13501-1, offering high fire safety performance for walls and ceilings.



### MAINTENANCE

Panels can be cleaned easily using a dust broom, vacuum cleaner, or a damp cloth.



## SOUND ABSORPTION

### M-SYSTEM WAVY - 4 cm GAP - MATERIAL 12 mm

Sound class D ( $\alpha_w=0.30$ ) [according to ISO 354:2003 & ISO 11654:1997]

### M-SYSTEM WAVY - 4 cm GAP - MATERIAL 24 mm

Sound class C ( $\alpha_w=0.61$ ) [according to ISO 354:2003 & ISO 11654:1997]

Absorption coefficient measurements

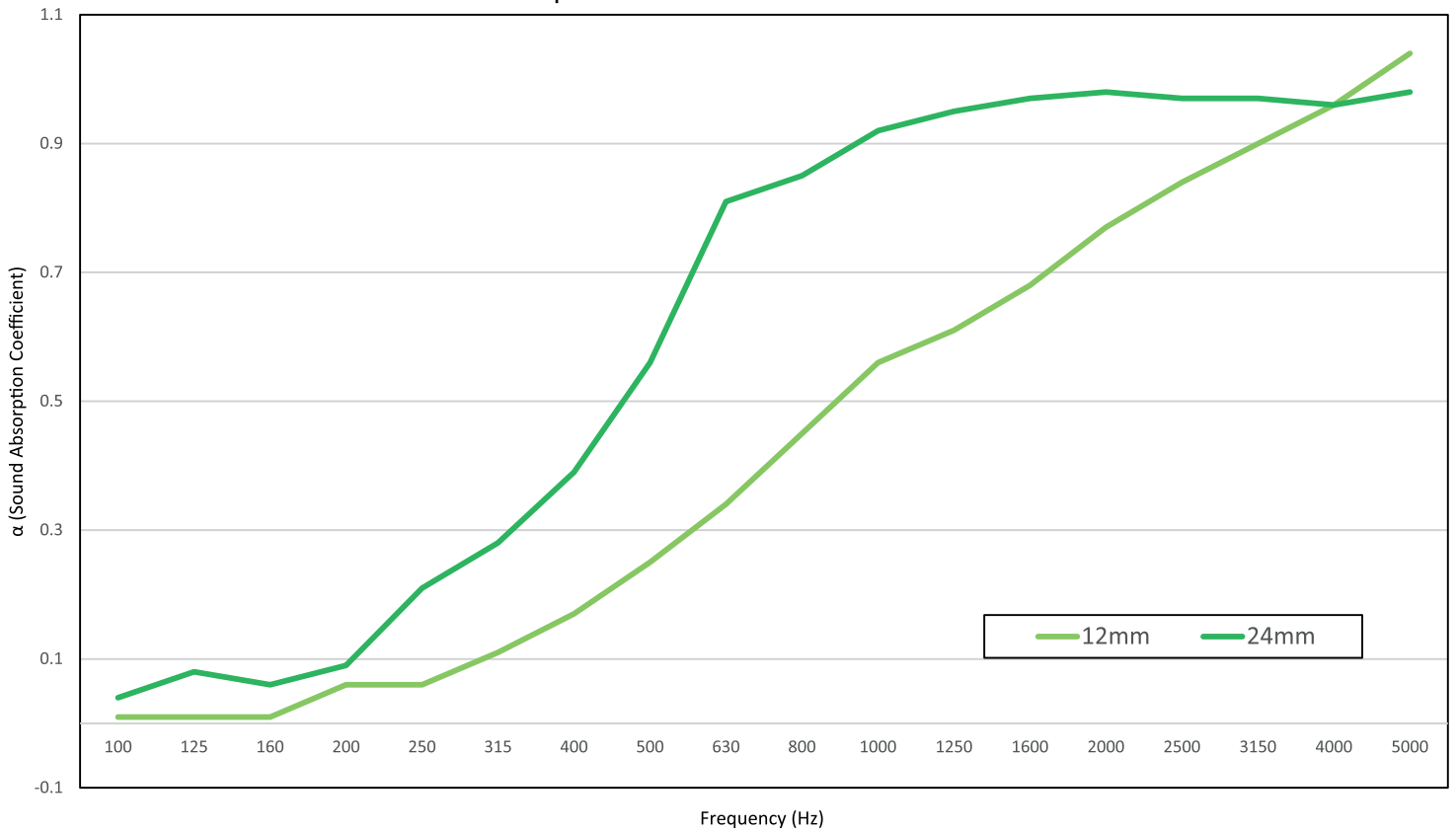

Frequency (Hz)	100	125	160	200	250	315	400	500	630	800	1000	1250	1600	2000	2500	3150	4000	5000
α <sub>s</sub> 12 mm	0.01	0.01	0.01	0.06	0.06	0.11	0.17	0.25	0.34	0.45	0.56	0.61	0.68	0.77	0.84	0.9	0.96	1.04
	0.01			0.08			0.25			0.54			0.76			0.97		
α <sub>s</sub> 24 mm	0.04	0.08	0.06	0.09	0.21	0.28	0.39	0.56	0.81	0.85	0.92	0.95	0.97	0.98	0.97	0.97	0.96	0.98
	0.06			0.19			0.59			0.91			0.97			0.97		

## SOUND ABSORPTION

### M-SYSTEM WAVY - 9 cm GAP - 12 mm - TYPE J MOUNTING

Sound class C ( $\alpha_w=0.56$ ) [according to ISO 354:2003]

### M-SYSTEM WAVY - 9 cm GAP - 24 mm - TYPE J MOUNTING

Sound class C ( $\alpha_w=0.62$ ) [according to ISO 354:2003]

Absorption coefficient measurements

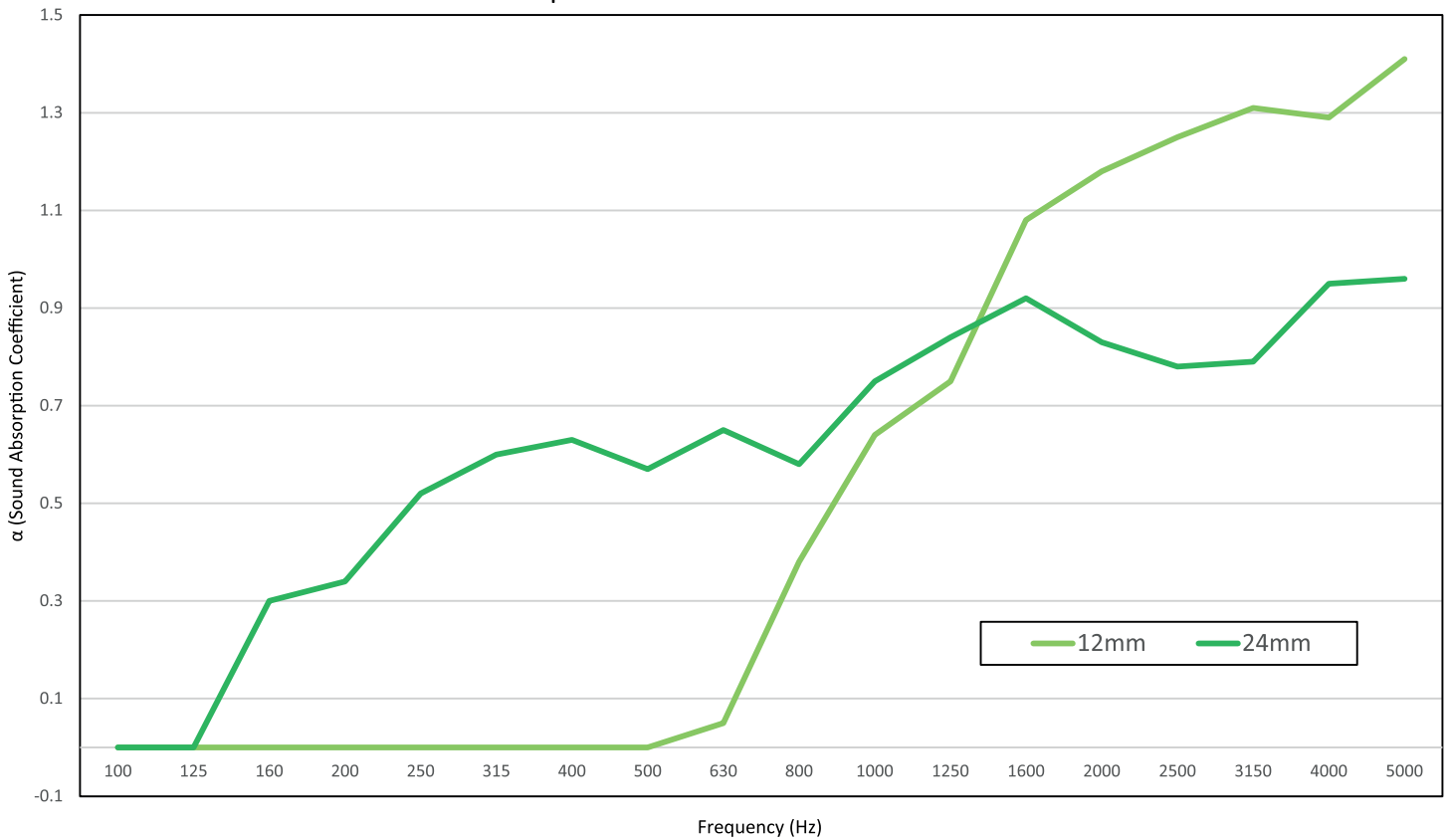

Frequency (Hz)	100	125	160	200	250	315	400	500	630	800	1000	1250	1600	2000	2500	3150	4000	5000
<b><math>\alpha_s</math></b>	0	0	0	0	0	0	0	0	0.05	0.38	0.64	0.75	1.08	1.18	1.25	1.31	1.29	1.41
<b>12 mm</b>	0.00			0.00			0.02			0.59			1.17			1.34		
<b><math>\alpha_s</math></b>	0	0	0.3	0.34	0.52	0.6	0.63	0.57	0.65	0.58	0.75	0.84	0.92	0.83	0.78	0.79	0.95	0.96
<b>24 mm</b>	0.10			0.49			0.62			0.72			0.84			0.90		

## STANDARD DIMENSIONS AND TYPES

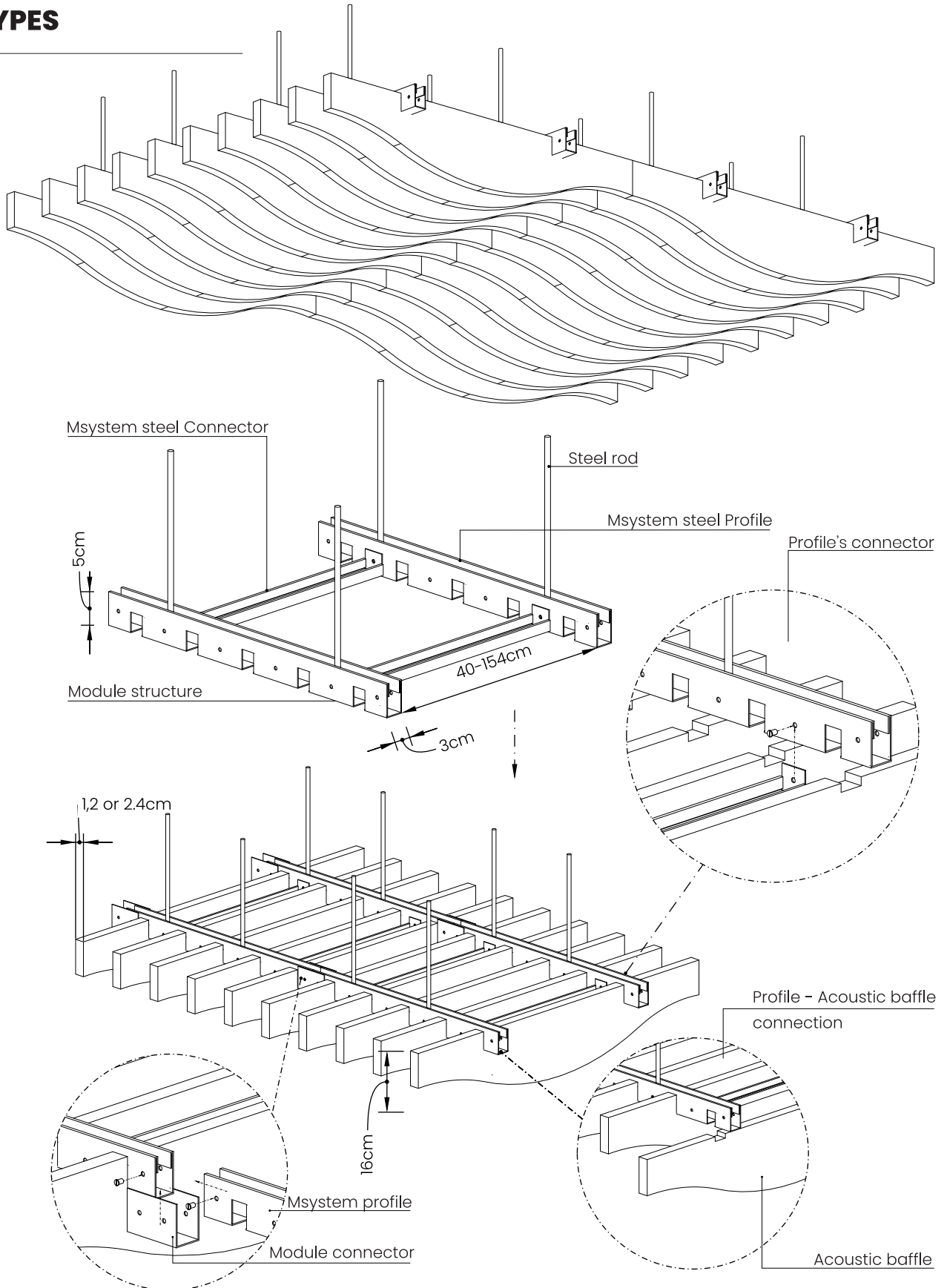

**STANDARD DIMENSIONS  
AND TYPES**

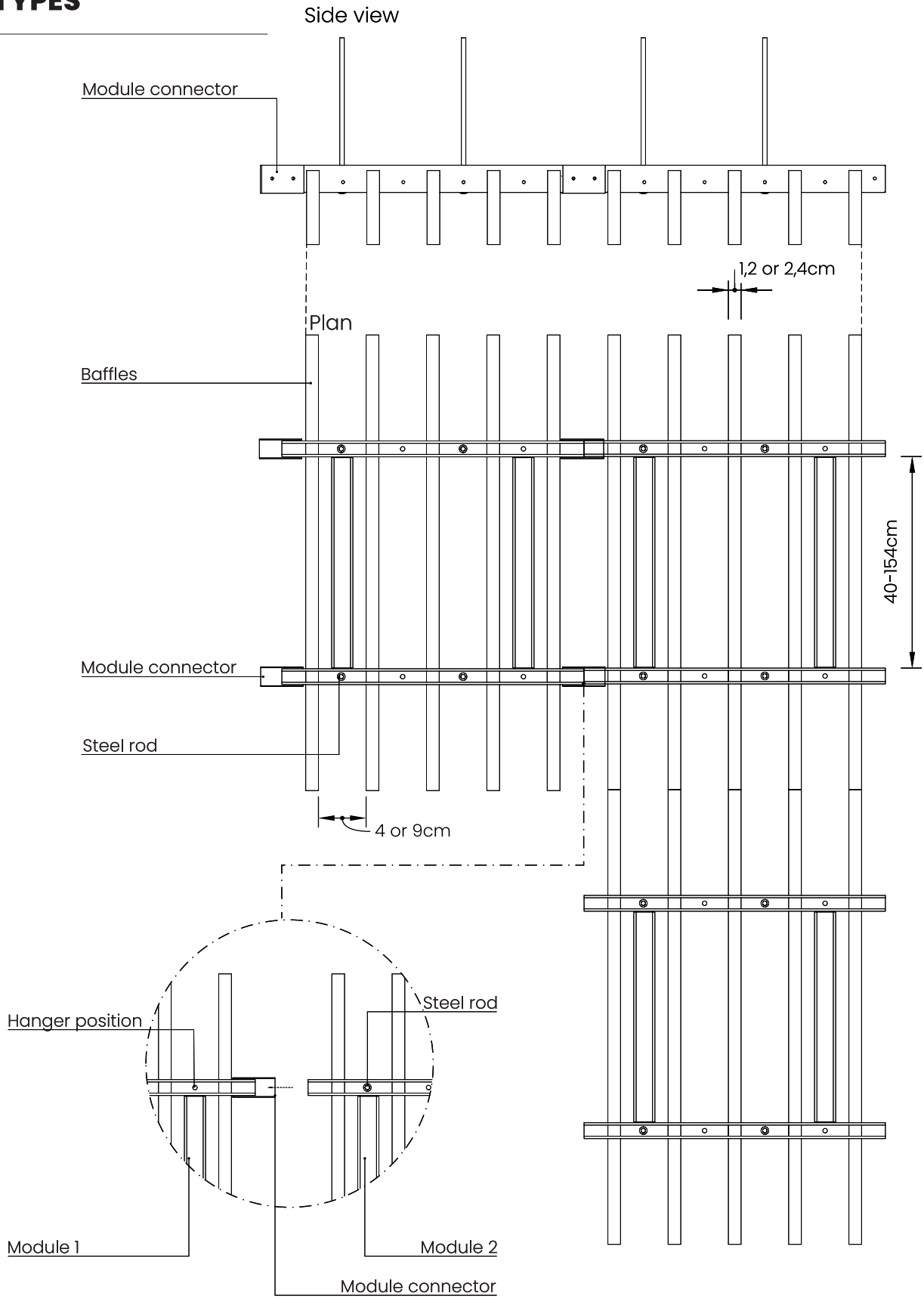

BEAM



---

## AVAILABLE SIZES

---

### MODULE SIZE

193.8 cm x 240 cm

### HEIGHT OF BAFFLES

16 cm

### HEIGHT OF SYSTEM

17 cm

### GAP BETWEEN BAFFLES

4 cm or 9 cm

### THICKNESS OF BAFFLES

50 mm

### SUPPORT TYPE

Galvanised steel structure

### HANGED METHOD

Galvanised threaded screw rod

### HANGED HEIGHT

Flexible (according to needs)

---

## MATERIALS AND COLORS

---

### MATERIALS

Polyester Fiber: 100% made from recycled PET.

### COLORS

Refer to Polyester Color Palette at page 179.

---

## TECHNICAL SPECIFICATIONS

---



### INSTALLATION

Installation can be carried out by mechanical fixing or suspension using a metal structure, on walls or ceilings.



### SUSTAINABILITY

Panels manufactured from 100% polyester fibre, containing a minimum of 75% post-consumer recycled PET sourced from recycled plastic bottles.



### NON TOXIC

Tested according to BS EN 717-1 (E0) for formaldehyde emissions. The panels contain no chemical binders or formaldehyde, supporting safer indoor air quality.



### FLAME RETARDANT

Panels rated Class B-s1, d0 according to EN 13501-1, offering high fire safety performance for walls and ceilings.



### MAINTENANCE

Panels can be cleaned easily using a dust broom, vacuum cleaner, or a damp cloth.

## SOUND ABSORPTION

### M-SYSTEM BEAM - 4 cm GAP - MATERIAL 12 mm

Sound class D ( $\alpha_w=0.30$ ) [according to ISO 354:2003 & ISO 11654:1997]

### M-SYSTEM BEAM - 4 cm GAP - MATERIAL 24 mm

Sound class C ( $\alpha_w=0.61$ ) [according to ISO 354:2003 & ISO 11654:1997]

Absorption coefficient measurements

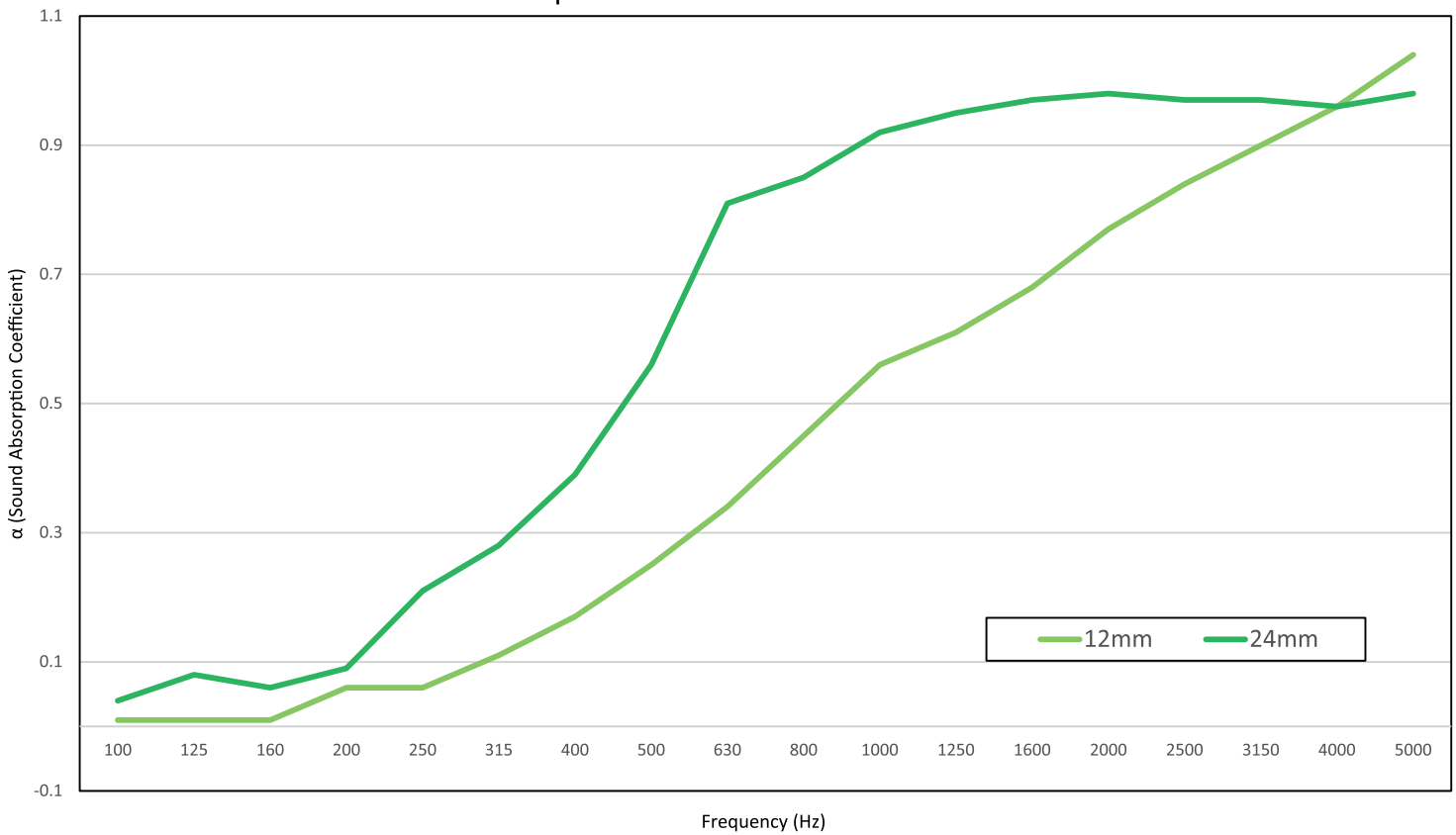

Frequency (Hz)	100	125	160	200	250	315	400	500	630	800	1000	1250	1600	2000	2500	3150	4000	5000
as 12 mm	0.01	0.01	0.01	0.06	0.06	0.11	0.17	0.25	0.34	0.45	0.56	0.61	0.68	0.77	0.84	0.9	0.96	1.04
		0.01			0.08			0.25			0.54			0.76			0.97	
as 24 mm	0.04	0.08	0.06	0.09	0.21	0.28	0.39	0.56	0.81	0.85	0.92	0.95	0.97	0.98	0.97	0.97	0.96	0.98
		0.06			0.19			0.59			0.91			0.97			0.97	

**STANDARD DIMENSIONS  
AND TYPES**

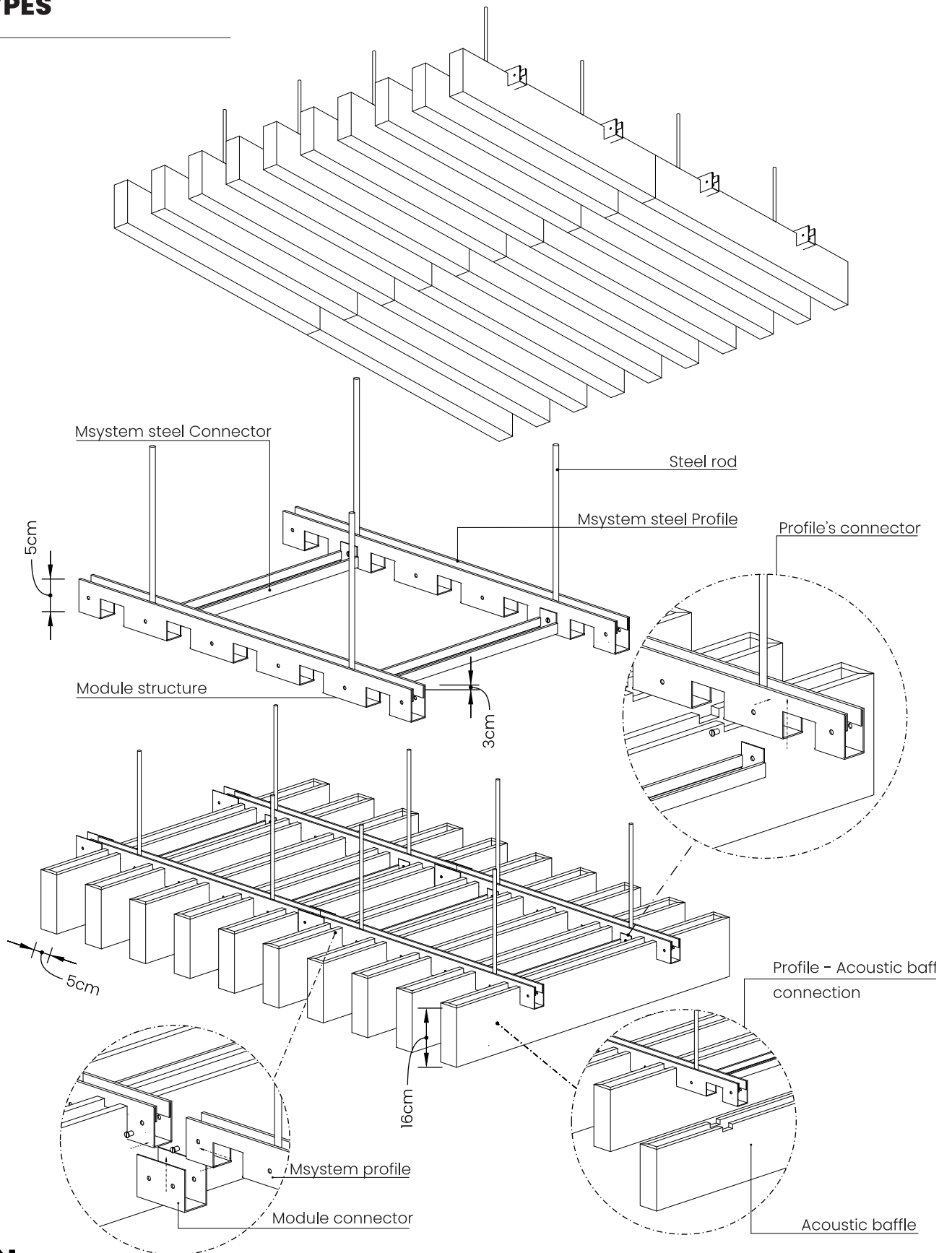



## STANDARD DIMENSIONS AND TYPES

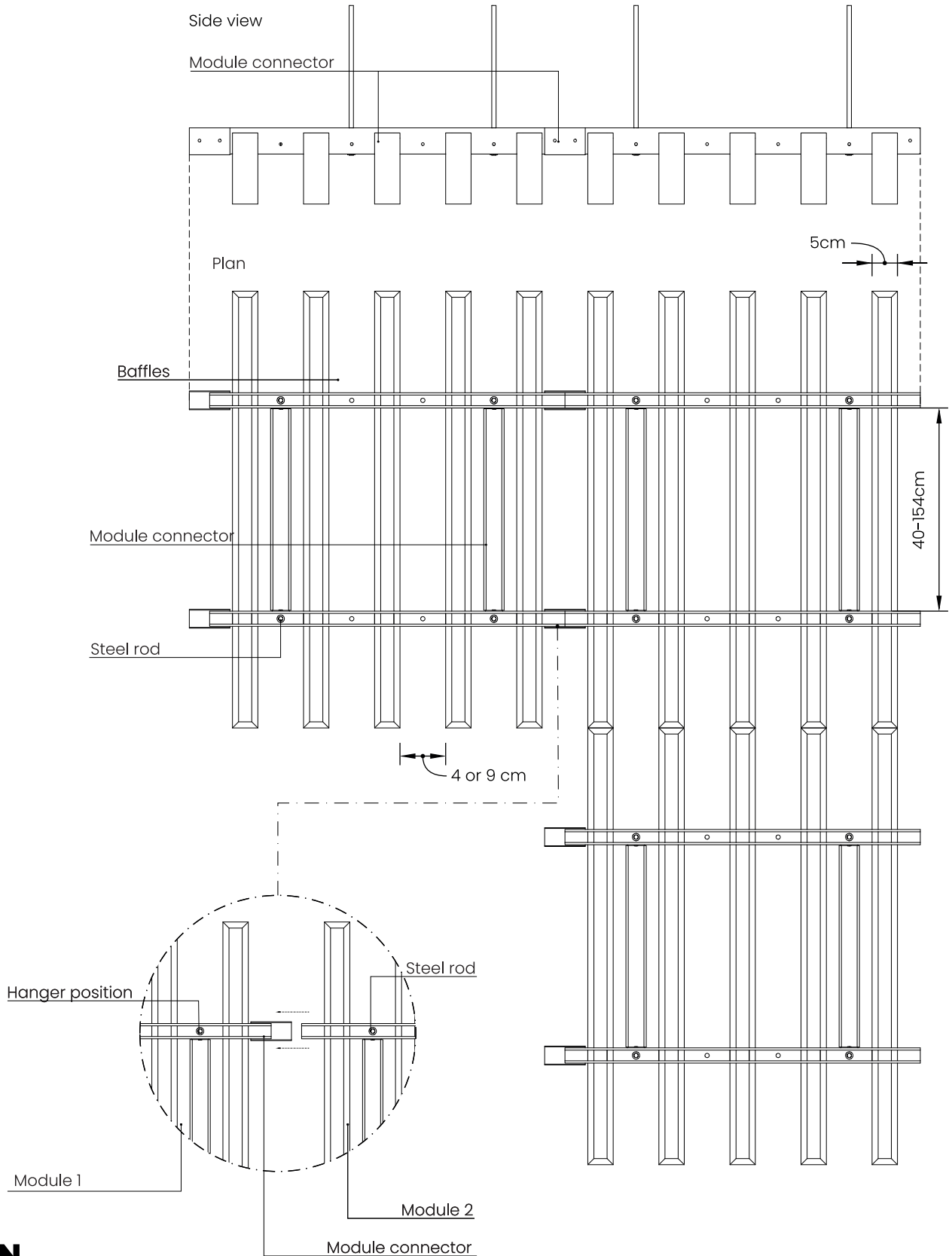



**EDGY**



**RHINO**



**CURVED**



**CROSS**



## MODULAR

---

MODULAR is a lightweight modular ceiling system made from recycled PET acoustic panels, designed to provide effective sound absorption while enhancing interior aesthetics.

Suitable for commercial, private, and specialized spaces, the suspended baffle system helps reduce reverberation and improve acoustic comfort in a wide range of environments.

The system is designed to function as a suspended (false) ceiling, installed using a durable metal wire rope system. This flexible installation method allows for seamless integration at various ceiling heights, adapting easily to the specific requirements of each project.

The system also allows seamless integration of building services such as HVAC systems, lighting fixtures, fire sprinklers, and audio equipment.

Combining acoustic performance, sustainable materials, and modern design, the MODULAR offers a cost-effective and visually striking ceiling solution for contemporary interior projects.

EDGY



## AVAILABLE SIZES

**MODULE SIZE**

Ø 120 cm & Ø 180cm

**MODULE HEIGHT (MAX)**

18 cm

**GAP BETWEEN BAFFLES**

10 cm

**THICKNESS OF BAFFLES**

12 mm

**HANGED METHOD**

Galvanised wire rope

**HANGED HEIGHT**

Flexible (according to needs)

## MATERIALS AND COLORS

**MATERIALS**

Polyester Fiber: 100% made from recycled PET.

**COLORS**

Refer to Polyester Color Palette at page 179.

## TECHNICAL SPECIFICATIONS



**INSTALLATION**

Installation can be carried out by suspension from the ceiling using steel wire rope.



**SUSTAINABILITY**

Panels manufactured from 100% polyester fibre, containing a minimum of 75% post-consumer recycled PET sourced from recycled plastic bottles.



**NON TOXIC**

Tested according to BS EN 717-1 (E0) for formaldehyde emissions. The panels contain no chemical binders or formaldehyde, supporting safer indoor air quality.



**FLAME RETARDANT**

Panels rated Class B-s1, d0 according to EN 13501-1, offering high fire safety performance for walls and ceilings.



**MAINTENANCE**

Panels can be cleaned easily using a dust broom, vacuum cleaner, or a damp cloth.



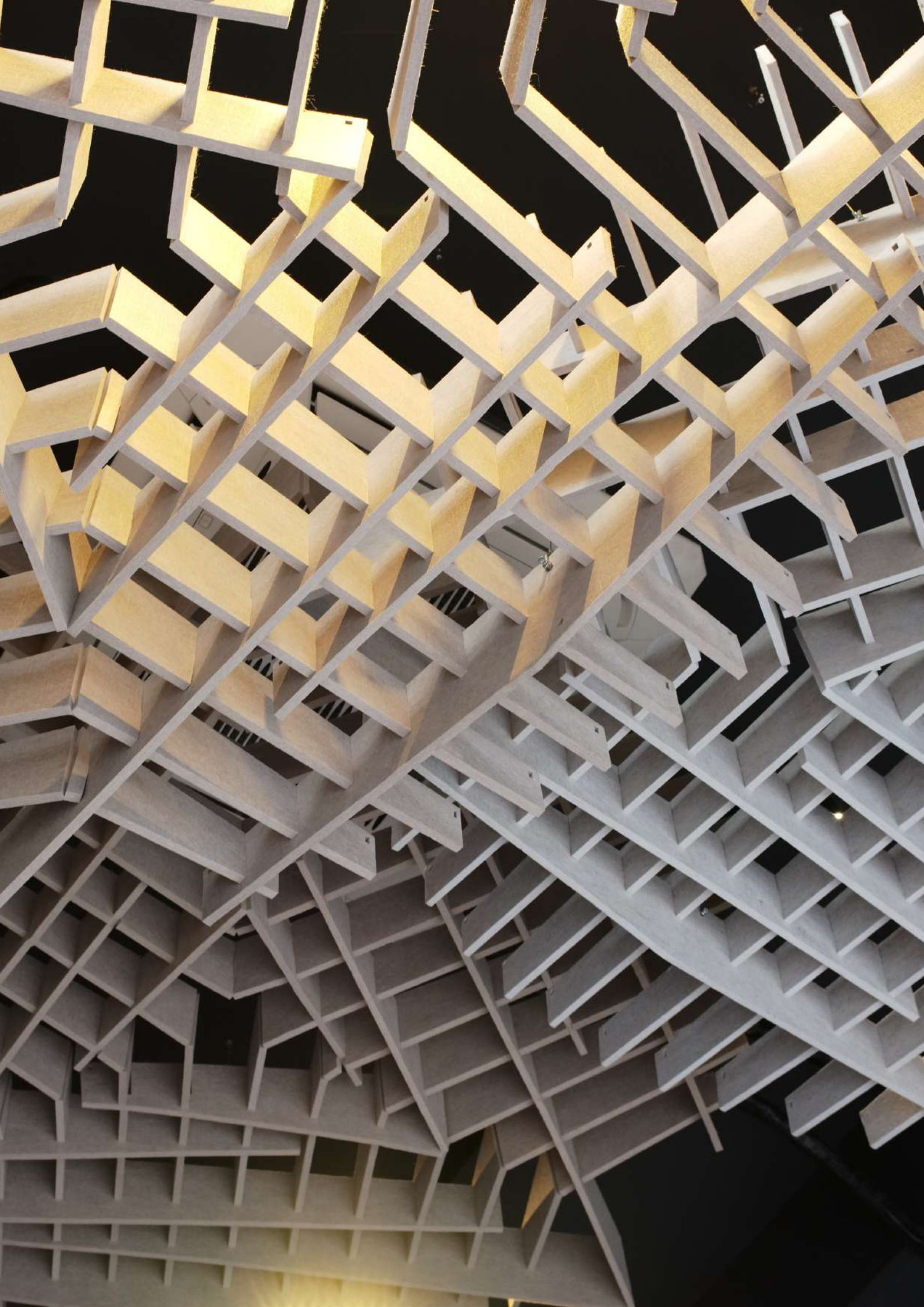

## SOUND ABSORPTION

### MODULAR PET MATERIAL

Sound class D ( $\alpha_w=0.30$ ) [according to ISO 354:2003 & ISO 11654:1997]

Absorption coefficient measurements

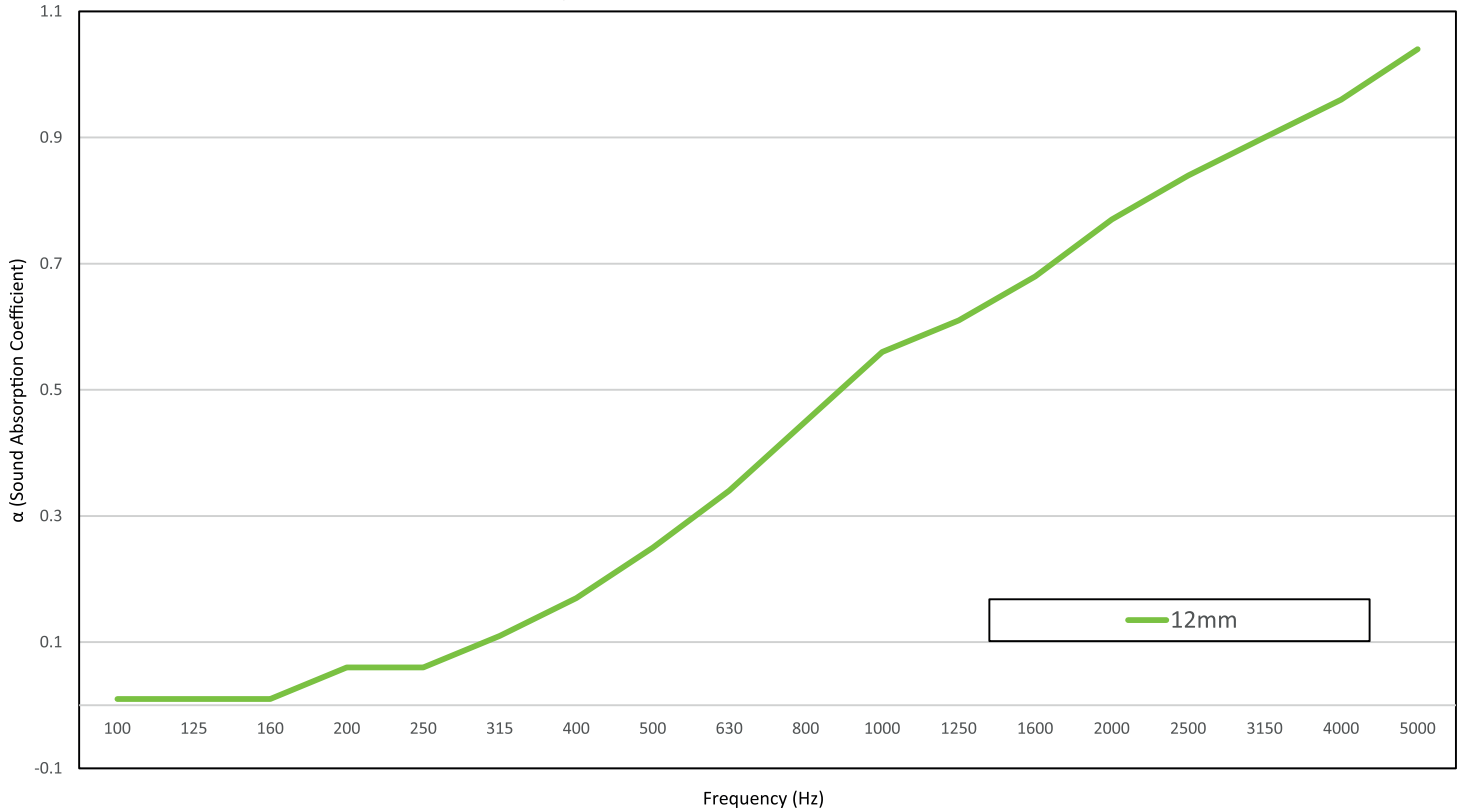

Frequency (Hz)	100	125	160	200	250	315	400	500	630	800	1000	1250	1600	2000	2500	3150	4000	5000
$\alpha_s$ 12mm	0.01	0.01	0.01	0.06	0.06	0.11	0.17	0.25	0.34	0.45	0.56	0.61	0.68	0.77	0.84	0.9	0.96	1.04
	0.01			0.08			0.25			0.54			0.76			0.97		



**STANDARD DIMENSIONS AND TYPES**

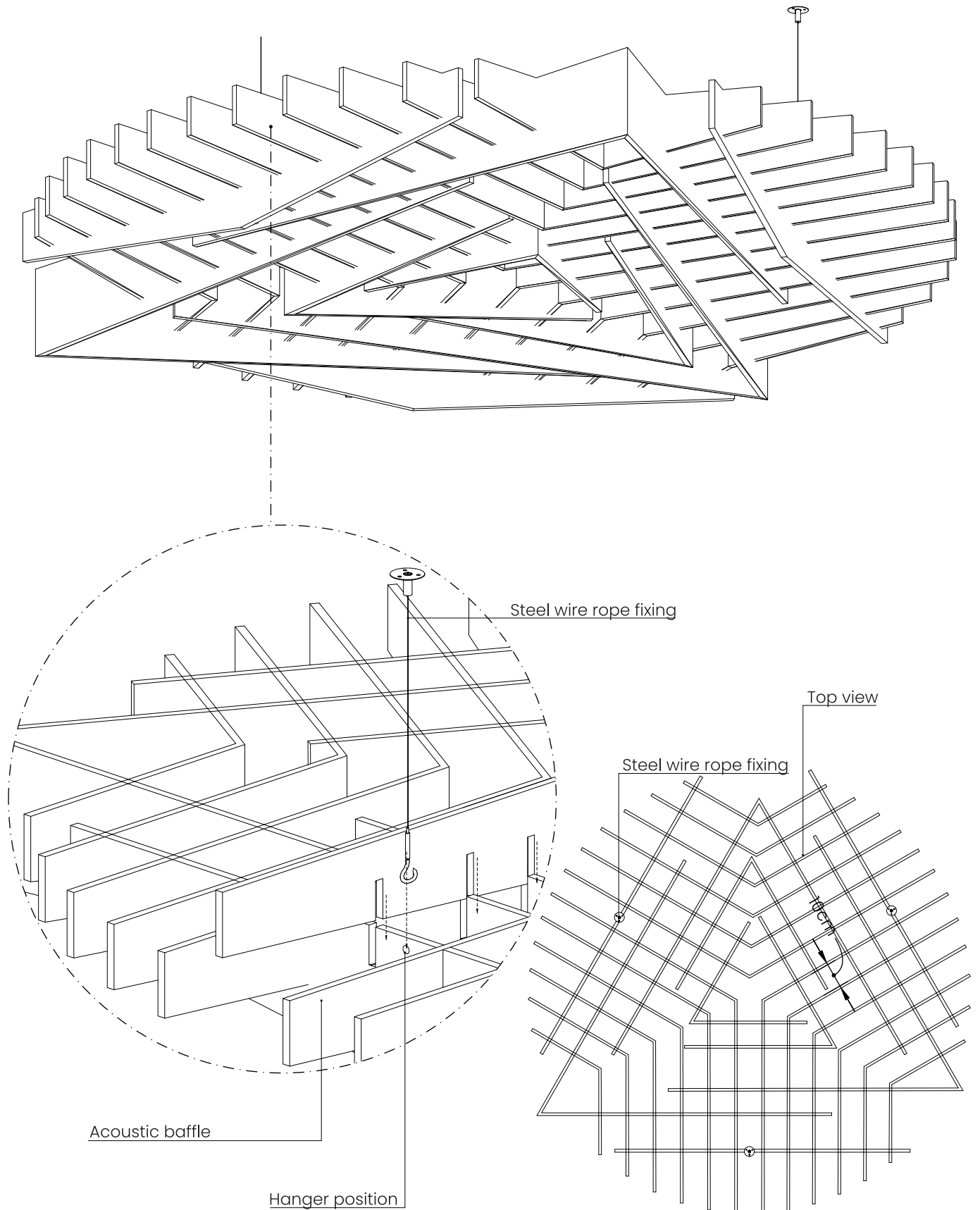

RHINO

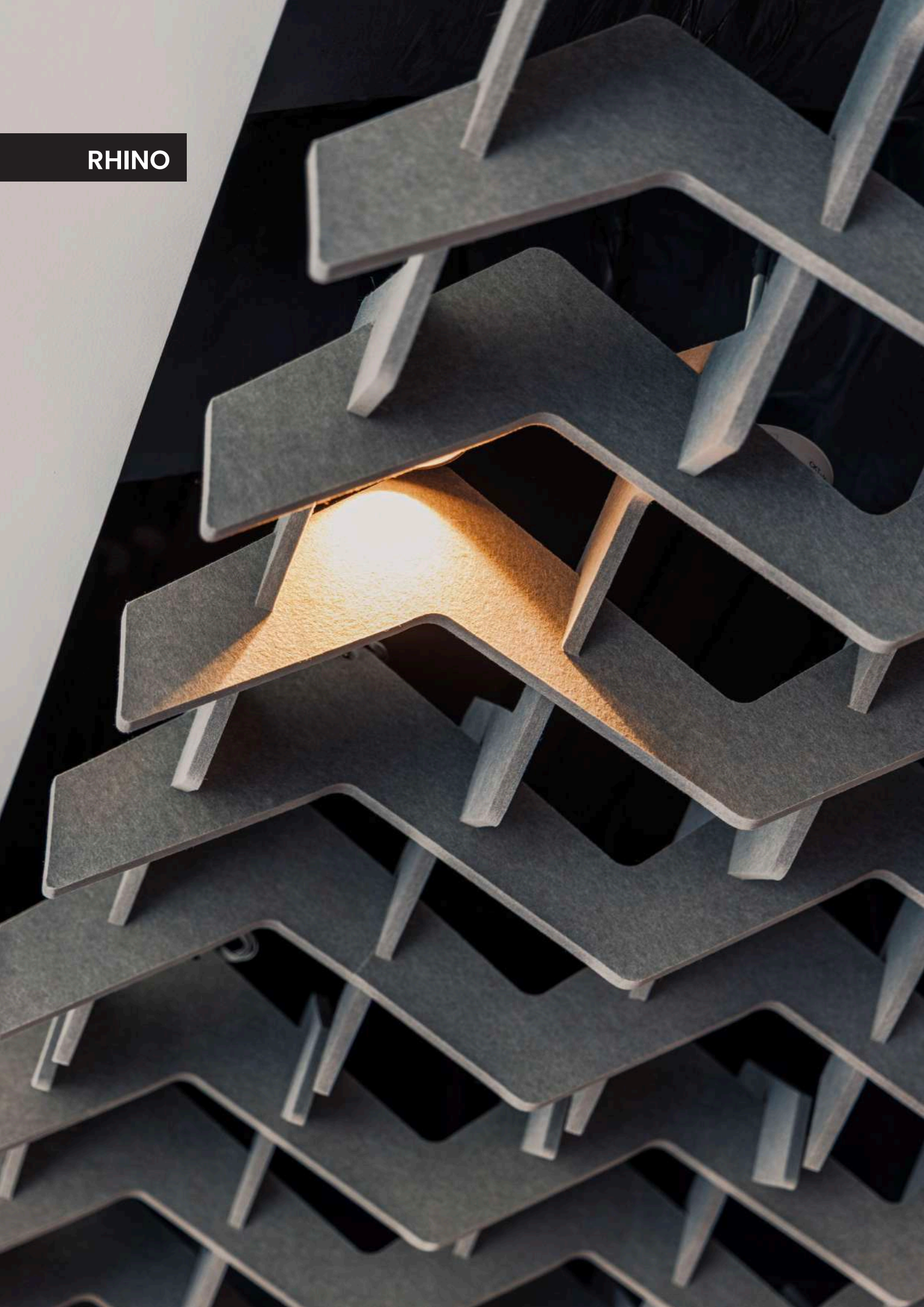

## AVAILABLE SIZES

**MODULE SIZE**

106 x 106 cm & 212 x 212 cm

**THICKNESS OF BAFFLES**

12 mm

**MODULE HEIGHT (MAX)**

30 cm

**HANGED METHOD**

Galvanised wire rope

**GAP BETWEEN BAFFLES**

20 cm

**HANGED HEIGHT**

Flexible (according to needs)

## MATERIALS AND COLORS

**MATERIALS**

Polyester Fiber: 100% made from recycled PET.

**COLORS**

Refer to Polyester Color Palette at page 179.

## TECHNICAL SPECIFICATIONS



**INSTALLATION**

Installation can be carried out by suspension from the ceiling using steel wire rope.



**SUSTAINABILITY**

Panels manufactured from 100% polyester fibre, containing a minimum of 75% post-consumer recycled PET sourced from recycled plastic bottles.



**NON TOXIC**

Tested according to BS EN 717-1 (E0) for formaldehyde emissions. The panels contain no chemical binders or formaldehyde, supporting safer indoor air quality.



**FLAME RETARDANT**

Panels rated Class B-s1, d0 according to EN 13501-1, offering high fire safety performance for walls and ceilings.



**MAINTENANCE**

Panels can be cleaned easily using a dust broom, vacuum cleaner, or a damp cloth.





## SOUND ABSORPTION

### MODULAR PET MATERIAL

Sound class D ( $\alpha_w=0.30$ ) [according to ISO 354:2003 & ISO 11654:1997]

Absorption coefficient measurements

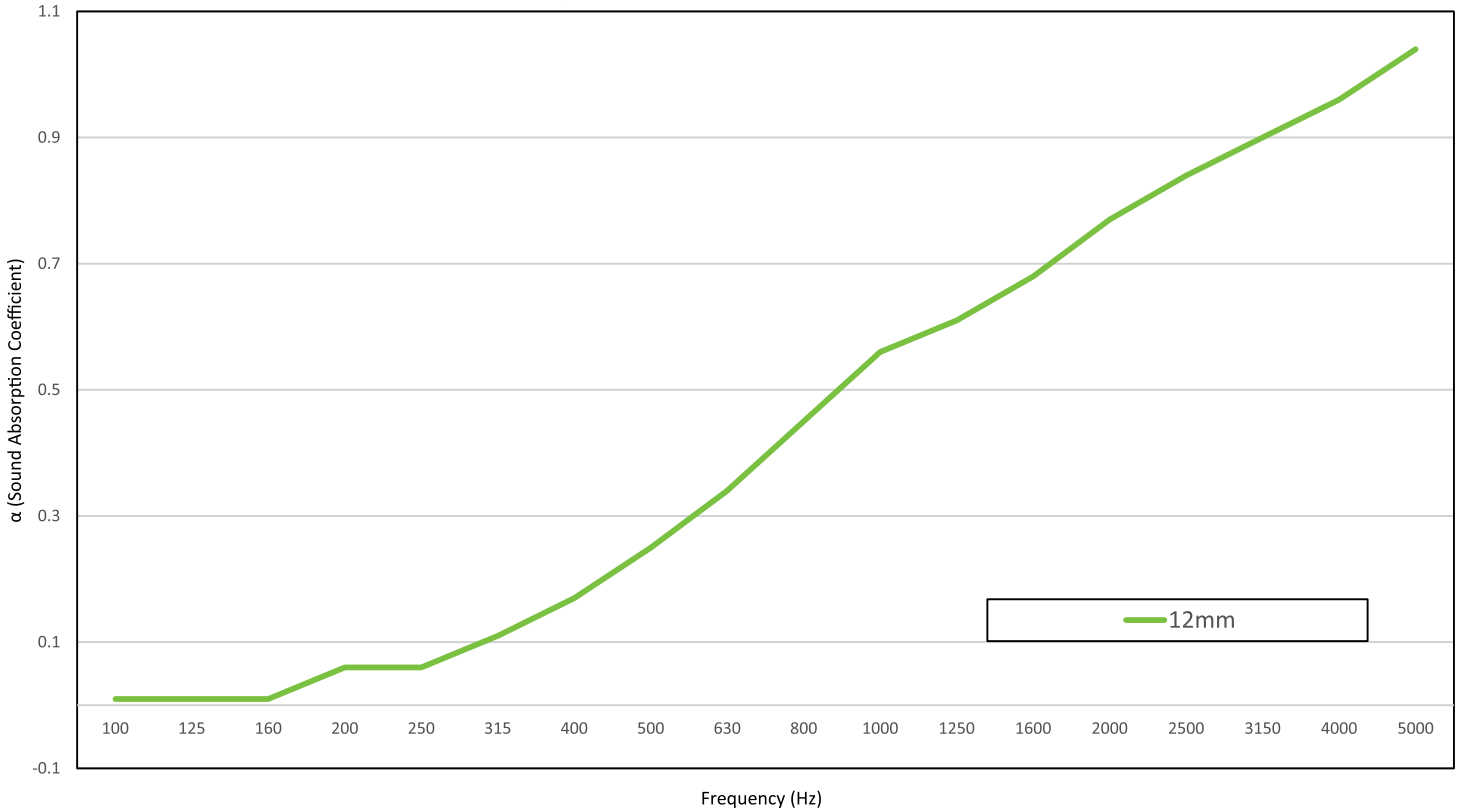

Frequency (Hz)	100	125	160	200	250	315	400	500	630	800	1000	1250	1600	2000	2500	3150	4000	5000
$\alpha_s$	0.01	0.01	0.01	0.06	0.06	0.11	0.17	0.25	0.34	0.45	0.56	0.61	0.68	0.77	0.84	0.9	0.96	1.04
12mm	0.01			0.08			0.25			0.54			0.76			0.97		



**STANDARD DIMENSIONS  
AND TYPES**

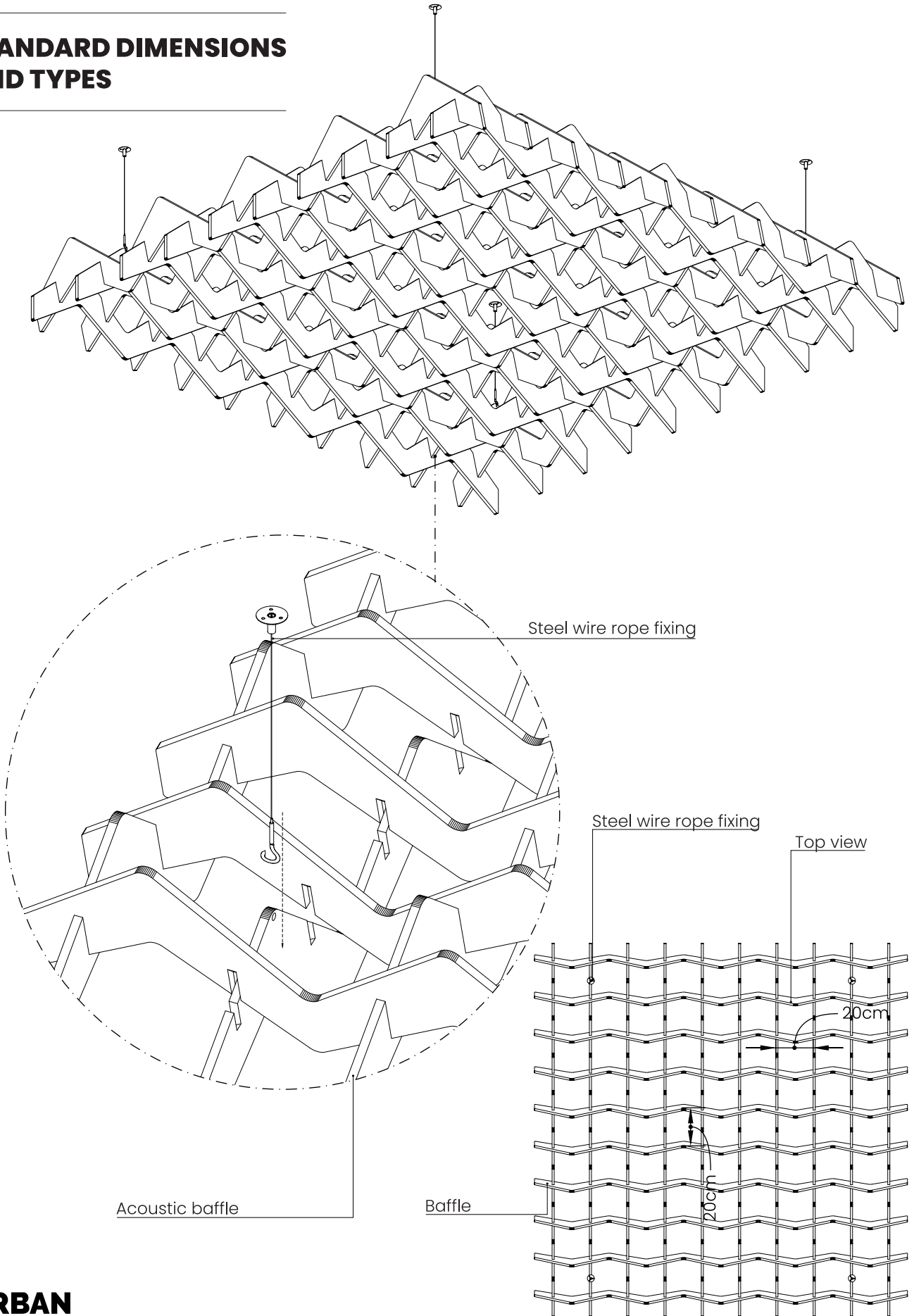

**CURVED**

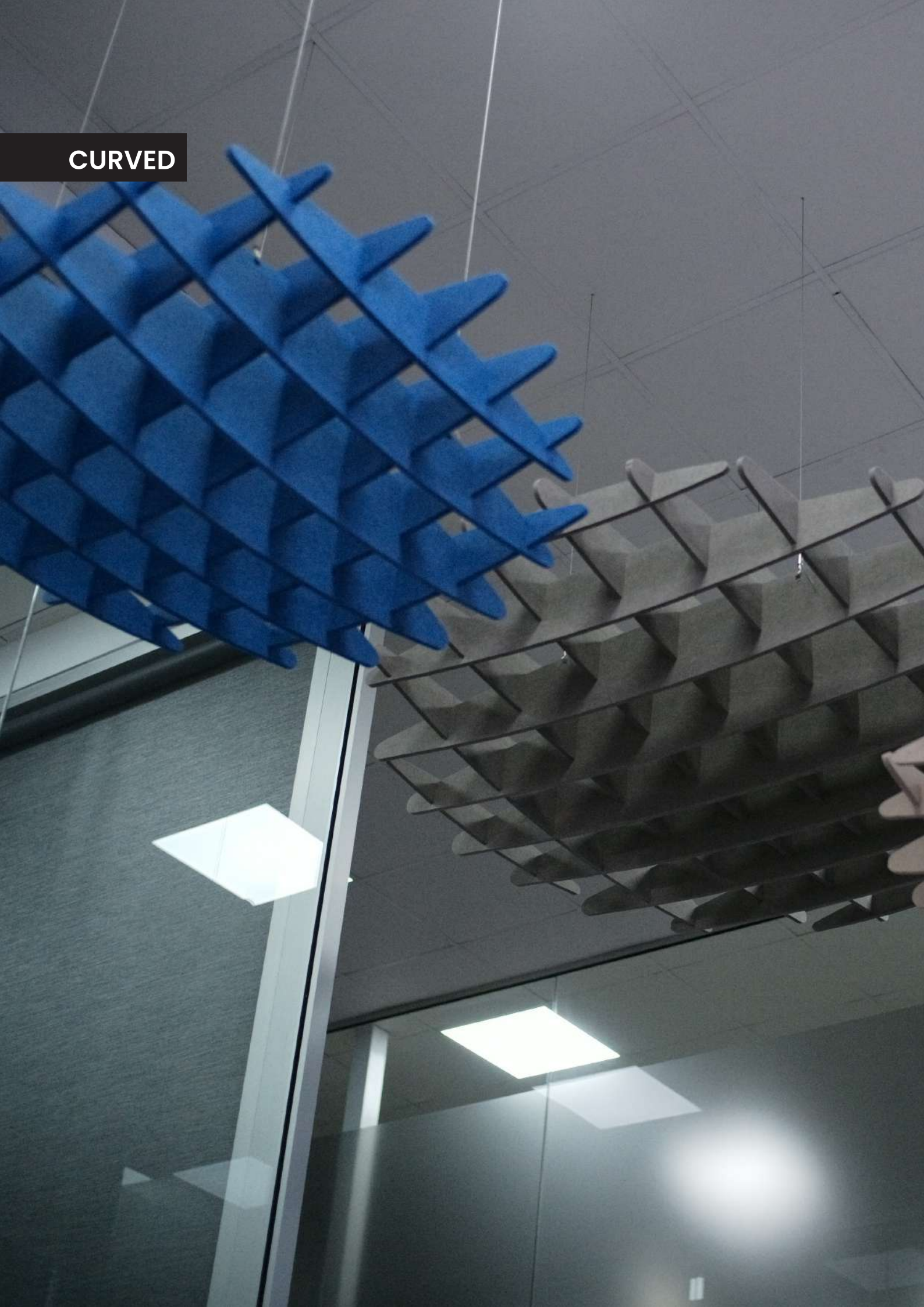

## AVAILABLE SIZES

**MODULE SIZE**

Ø 120 cm & Ø 180 cm

**MODULE HEIGHT (MAX)**

27 cm

**GAP BETWEEN BAFFLES**

13.8 cm

**THICKNESS OF BAFFLES**

12 mm

**HANGED METHOD**

Galvanised wire rope

**HANGED HEIGHT**

Flexible (according to needs)

## MATERIALS AND COLORS

**MATERIALS**

Polyester Fiber: 100% made from recycled PET.

**COLORS**

Refer to Polyester Color Palette at page 179.

## TECHNICAL SPECIFICATIONS



**INSTALLATION**

Installation can be carried out by suspension from the ceiling using steel wire rope.



**SUSTAINABILITY**

Panels manufactured from 100% polyester fibre, containing a minimum of 75% post-consumer recycled PET sourced from recycled plastic bottles.



**NON TOXIC**

Tested according to BS EN 717-1 (E0) for formaldehyde emissions. The panels contain no chemical binders or formaldehyde, supporting safer indoor air quality.



**FLAME RETARDANT**

Panels rated Class B-s1, d0 according to EN 13501-1, offering high fire safety performance for walls and ceilings.



**MAINTENANCE**

Panels can be cleaned easily using a dust broom, vacuum cleaner, or a damp cloth.





## SOUND ABSORPTION

### MODULAR PET MATERIAL

Sound class D ( $\alpha_w=0.30$ ) [according to ISO 354:2003 & ISO 11654:1997]

Absorption coefficient measurements

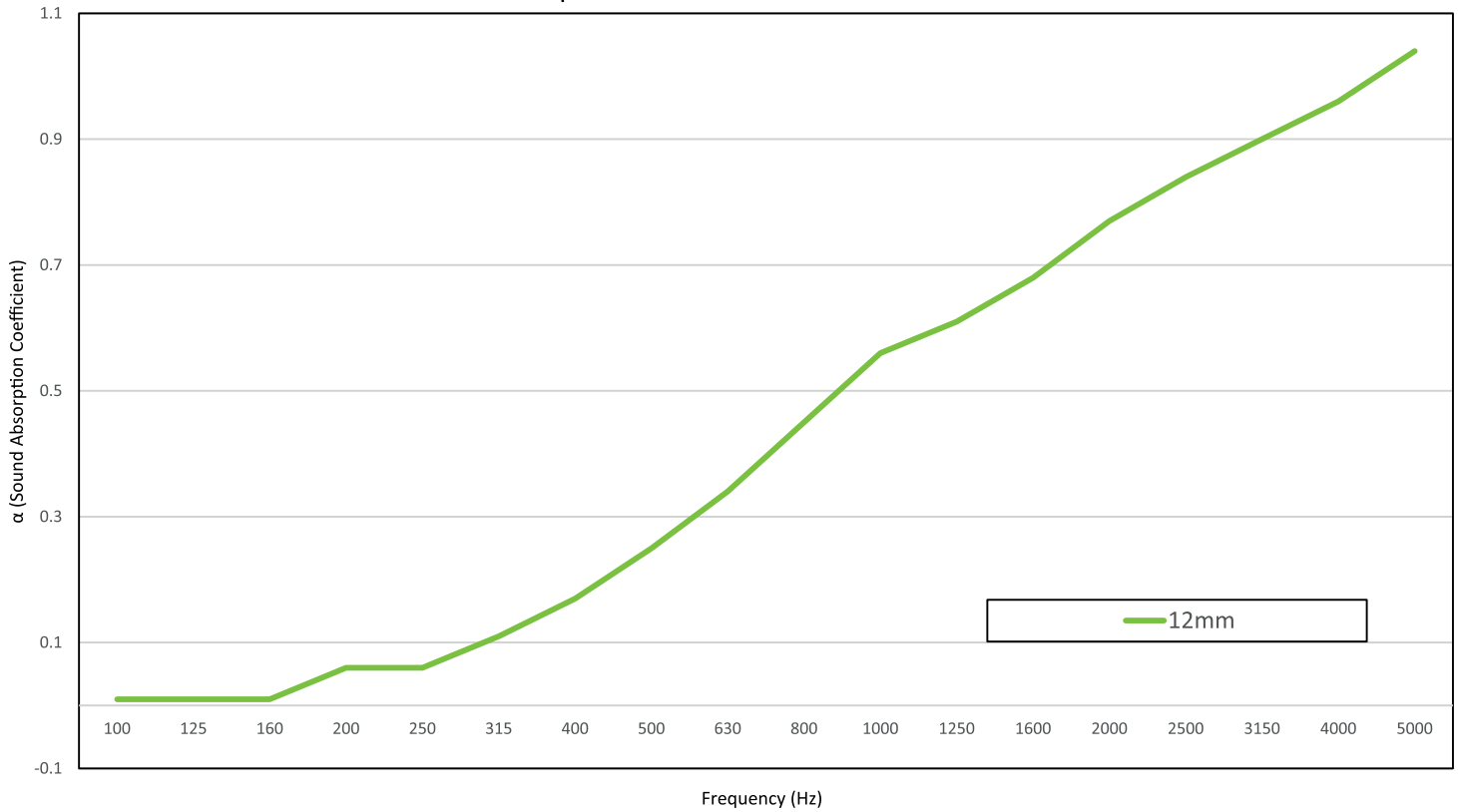

Frequency (Hz)	100	125	160	200	250	315	400	500	630	800	1000	1250	1600	2000	2500	3150	4000	5000
$\alpha_s$	0.01	0.01	0.01	0.06	0.06	0.11	0.17	0.25	0.34	0.45	0.56	0.61	0.68	0.77	0.84	0.9	0.96	1.04
12mm	0.01			0.08			0.25			0.54			0.76			0.97		



**STANDARD DIMENSIONS  
AND TYPES**

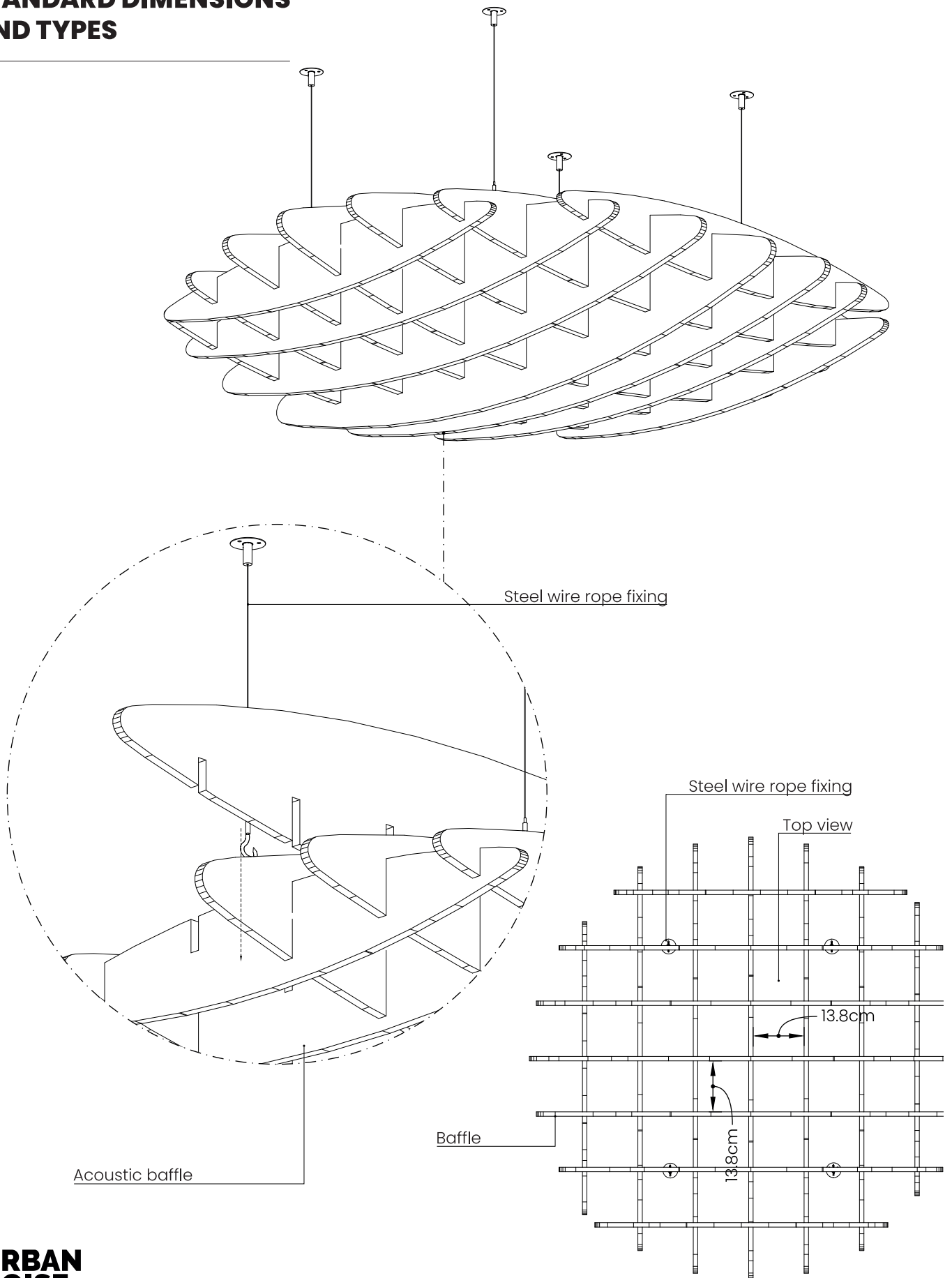

CROSS



---

## AVAILABLE SIZES

---

### MODULE SIZE

106 x 106 cm & 212 x 212 cm

### THICKNESS OF BAFFLES

12 mm

### MODULE HEIGHT (MAX)

16 cm

### HANGED METHOD

Galvanised wire rope

### GAP BETWEEN BAFFLES

20 cm

### HANGED HEIGHT

Flexible (according to needs)

---

## MATERIALS AND COLORS

---

### MATERIALS

Polyester Fiber: 100% made from recycled PET.

### COLORS

Refer to Polyester Color Palette at page 179.

---

## TECHNICAL SPECIFICATIONS

---



### INSTALLATION

Installation can be carried out by suspension from the ceiling using steel wire rope.



### SUSTAINABILITY

Panels manufactured from 100% polyester fibre, containing a minimum of 75% post-consumer recycled PET sourced from recycled plastic bottles.



### NON TOXIC

Tested according to BS EN 717-1 (E0) for formaldehyde emissions. The panels contain no chemical binders or formaldehyde, supporting safer indoor air quality.



### FLAME RETARDANT

Panels rated Class B-s1, d0 according to EN 13501-1, offering high fire safety performance for walls and ceilings.



### MAINTENANCE

Panels can be cleaned easily using a dust broom, vacuum cleaner, or a damp cloth.



## SOUND ABSORPTION

### MODULAR PET MATERIAL

Sound class D ( $\alpha_w=0.30$ ) [according to ISO 354:2003 & ISO 11654:1997]

Absorption coefficient measurements

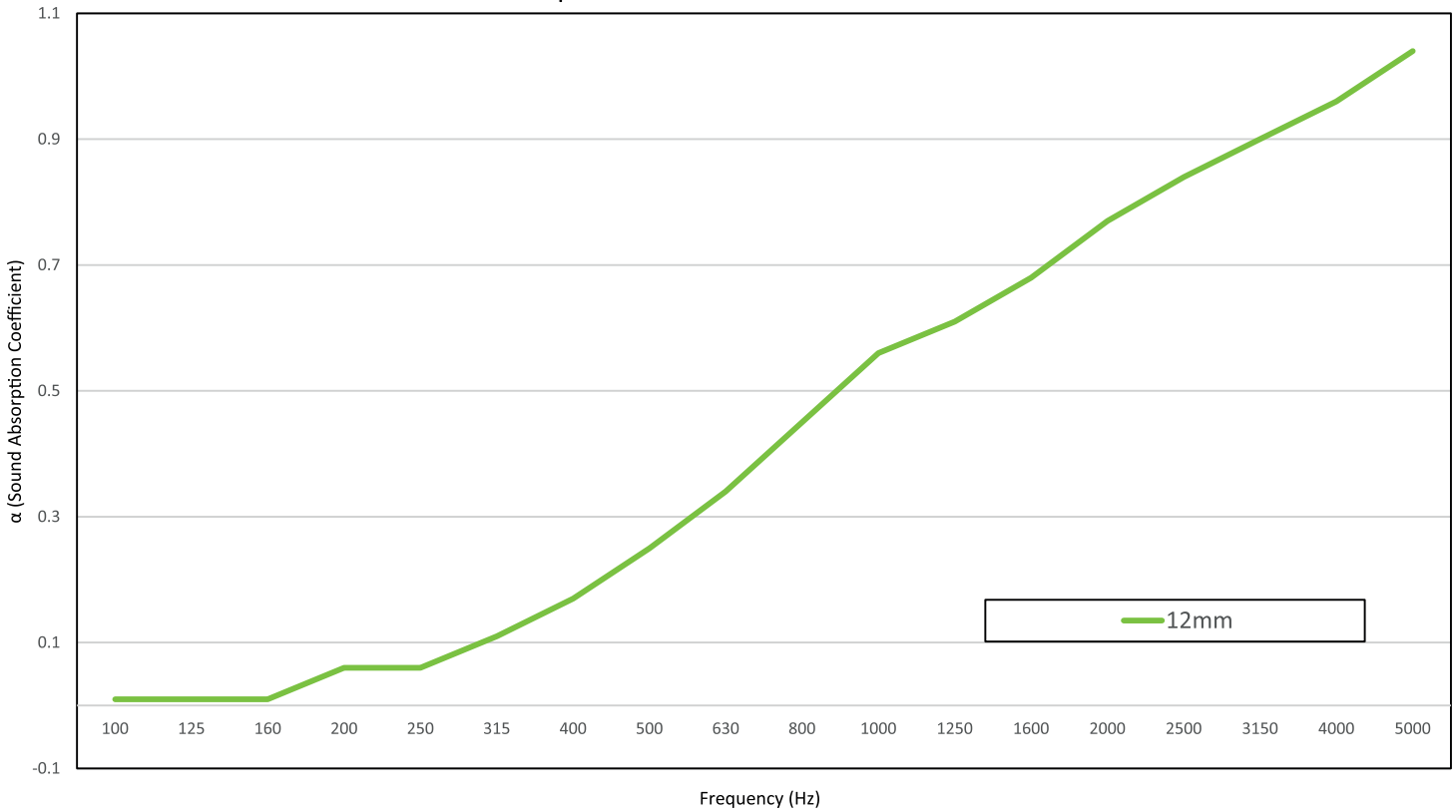

Frequency (Hz)	100	125	160	200	250	315	400	500	630	800	1000	1250	1600	2000	2500	3150	4000	5000
$\alpha_s$	0.01	0.01	0.01	0.06	0.06	0.11	0.17	0.25	0.34	0.45	0.56	0.61	0.68	0.77	0.84	0.9	0.96	1.04
12mm	0.01			0.08			0.25			0.54			0.76			0.97		



**STANDARD DIMENSIONS  
AND TYPES**

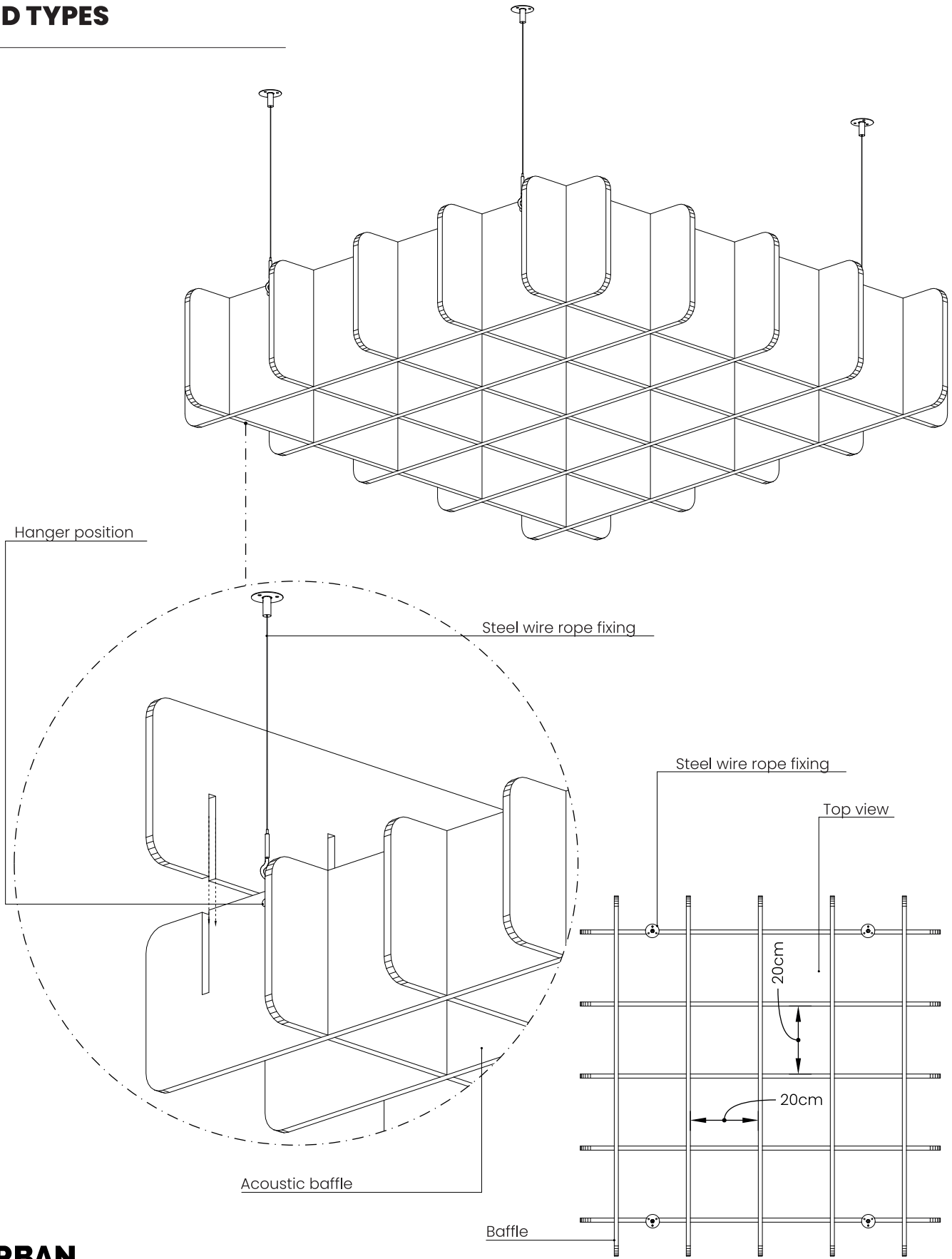

**FLOWER**



**POLYCLOUD**

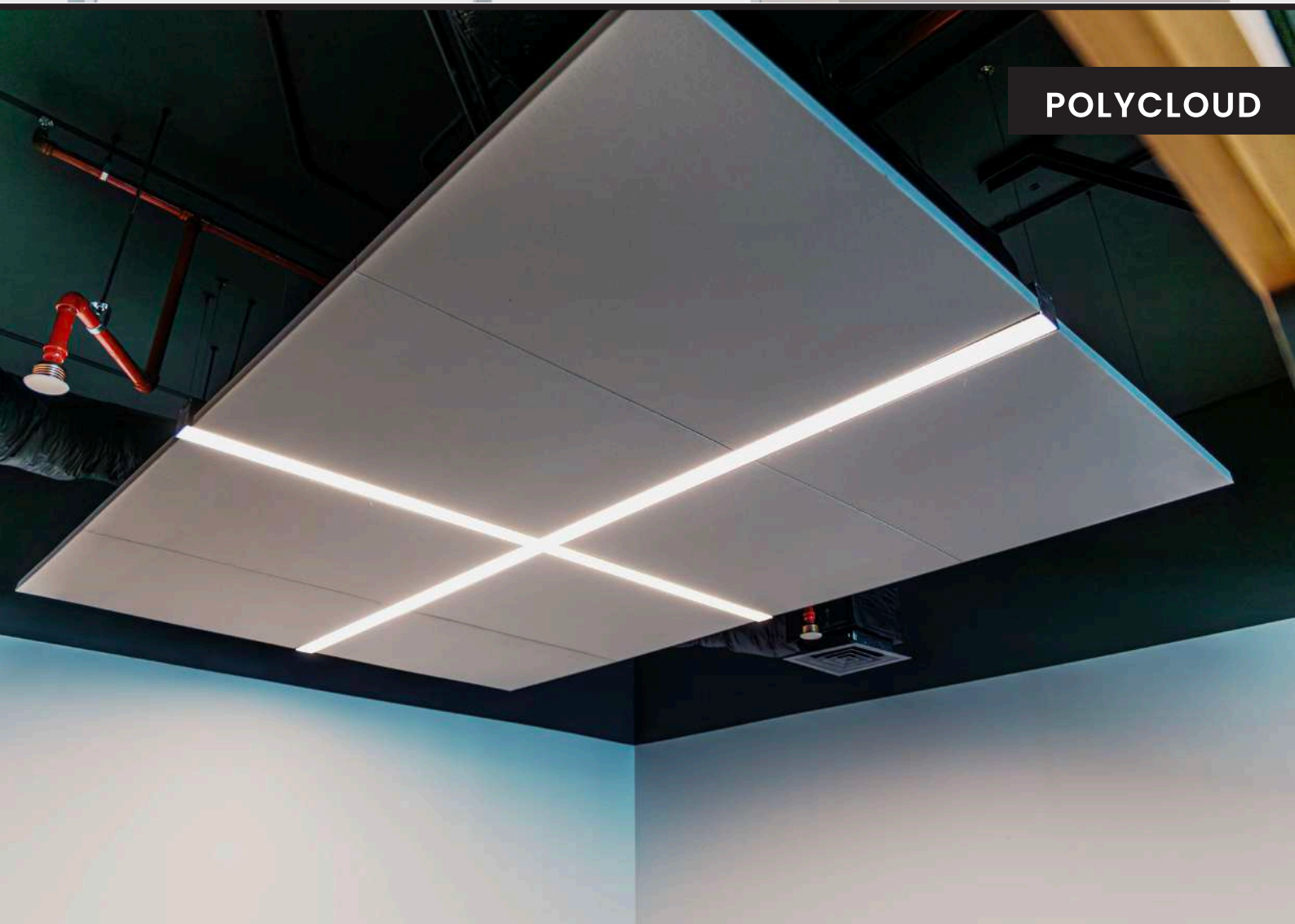

## TESSERA

---

TESSERA is a solid suspended acoustic system designed for ceiling installation. The system consists of recycled polyester fiber acoustic elements supported by a steel structural frame, providing high sound absorption performance while enhancing the visual quality of interior spaces.

It is suitable for a wide range of environments, including private, commercial, and specialized spaces where acoustic comfort and architectural aesthetics are required.

Installation is achieved through suspension from the ceiling using adjustable steel wire ropes, allowing flexible height positioning and easy integration within different architectural layouts.

The system can function as a floating acoustic ceiling solution, enabling the integration or coordination of building services such as HVAC units, lighting fixtures, fire sprinkler systems, speakers, and other technical installations either above, below, or in between the acoustic elements.

TESSERA offers a visually distinctive ceiling design while delivering effective acoustic performance through a cost-efficient and sustainable solution.

# FLOWER



---

## AVAILABLE SIZES

---

### SYSTEM SIZE

152 cm x 177 cm x 27 cm (L x W x H)

### PET THICKNESS

12 mm

### HANGED METHOD

Suspension using a galvanised steel hook and steel wire rope.

### HANGED HEIGHT

Flexible and height-adjustable.

---

## GEOMETRIC CONFIGURATION

---

Four triangular elements form a rhombus module, and three rhombus modules combine to create the characteristic flower-shaped configuration.

---

## MATERIALS AND COLORS

---

### MATERIALS

Polyester Fiber: 100% made from recycled PET.

### COLORS

Refer to Polyester Color Palette at page 179.

---

## TECHNICAL SPECIFICATIONS

---



### INSTALLATION

Installation can be carried out by suspension from the ceiling using wire rope.



### SUSTAINABILITY

PET panels manufactured from 100% polyester fibre, containing a minimum of 75% post-consumer recycled PET sourced from recycled plastic bottles. Galvanised steel components are durable and recyclable, contributing to long service life and reduced environmental impact. The protective zinc coating extends the material's lifespan and supports sustainable use.



### NON TOXIC

Tested according to BS EN 717-1 (E0) for formaldehyde emissions. The PET panels contain no chemical binders or formaldehyde, supporting safer indoor air quality. Galvanised steel is a stable material that does not release harmful substances under normal indoor conditions, supporting safe indoor environments.



### FLAME RETARDANT

PET panels rated Class B-s1, d0 according to EN 13501-1, offering high fire safety performance for walls and ceilings. Galvanised steel is a non-combustible material, providing reliable fire resistance for use in wall and ceiling systems.



### MAINTENANCE

PET Panels can be cleaned easily using a dust broom, vacuum cleaner, or a damp cloth. Galvanised steel surfaces require minimal maintenance and can be cleaned with a soft cloth and mild cleaning agents to preserve their protective coating and appearance.



## SOUND ABSORPTION

### PET MATERIAL 12 mm

Sound class D ( $\alpha_w=0.30$ ) [according to ISO 354:2003 & ISO 11654:1997]

Absorption coefficient measurements

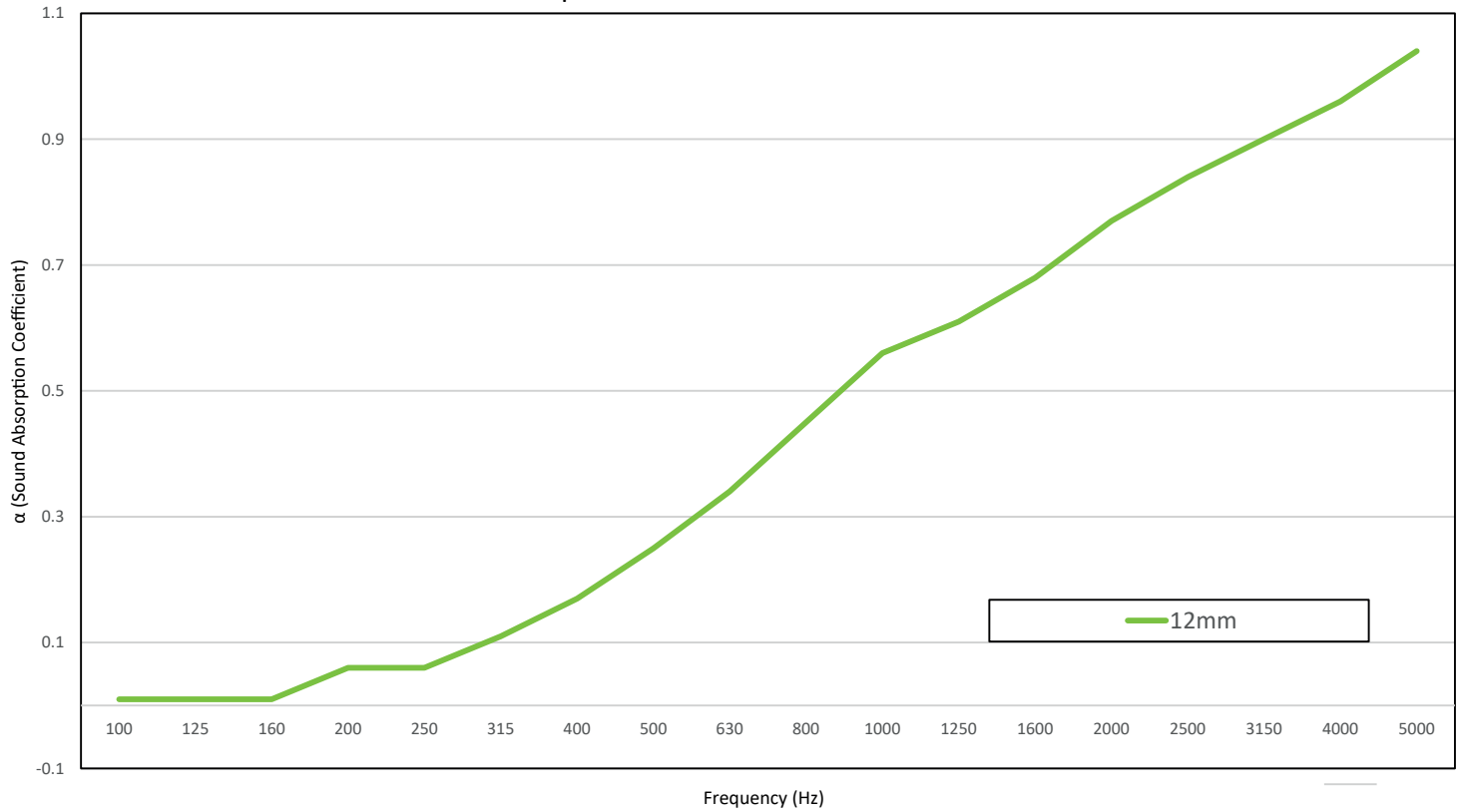

Frequency (Hz)	100	125	160	200	250	315	400	500	630	800	1000	1250	1600	2000	2500	3150	4000	5000
$\alpha_s$ 12mm	0.01	0.01	0.01	0.06	0.06	0.11	0.17	0.25	0.34	0.45	0.56	0.61	0.68	0.77	0.84	0.9	0.96	1.04
	0.01			0.08			0.25			0.54			0.76			0.97		



**STANDARD DIMENSIONS AND TYPES**

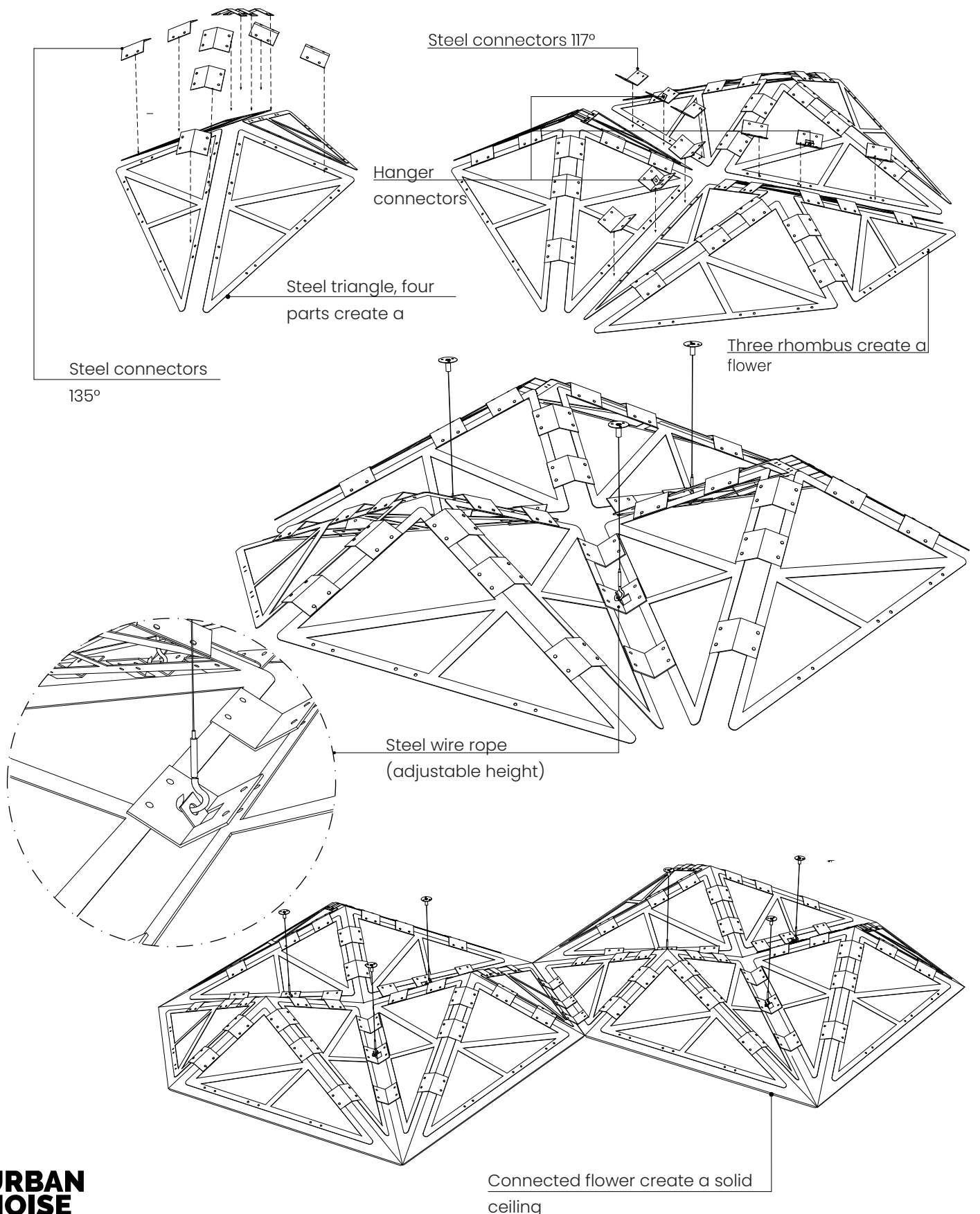



**STANDARD DIMENSIONS AND TYPES**

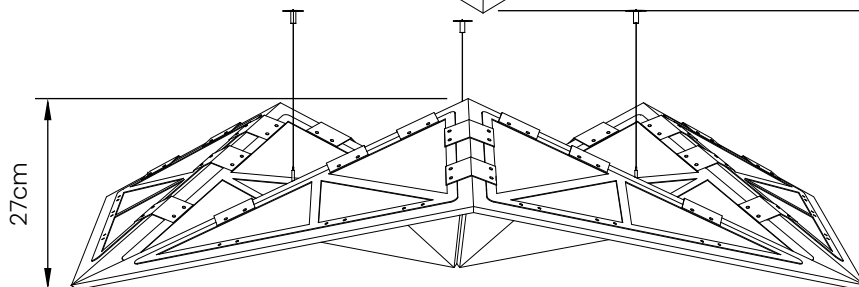
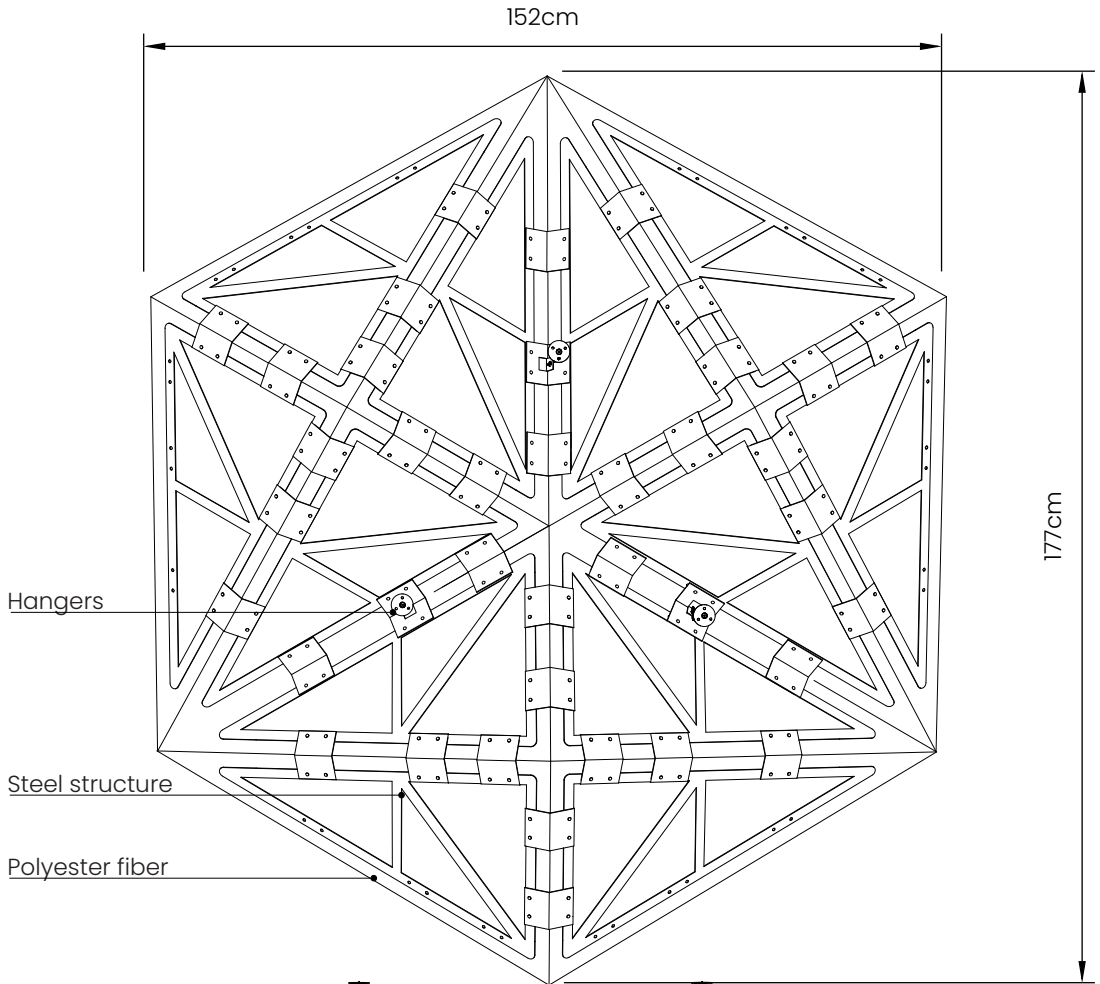
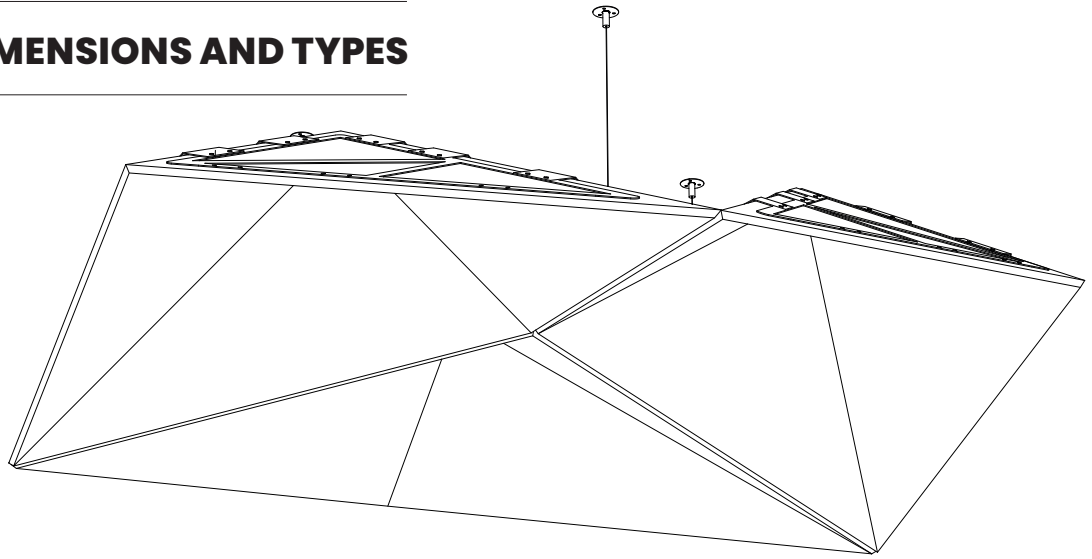

**POLYCLOUD**



---

## AVAILABLE SIZES

---

### PANEL SIZE

100 cm x 74 cm x 3 cm (L x W x H)

### PET THICKNESS

12 mm

### HANGED METHOD

Suspension using a galvanised steel hook and steel wire rope.

### HANGED HEIGHT

Flexible and height-adjustable.

---

## GEOMETRIC CONFIGURATION

---

Two rectangular panels positioned side by side for optimal balance and visual symmetry.

---

## MATERIALS AND COLORS

---

### MATERIALS

Polyester Fiber: 100% made from recycled PET.

### COLORS

Refer to Polyester Color Palette at page 179.

---

## TECHNICAL SPECIFICATIONS

---



### INSTALLATION

Installation can be carried out by suspension from the ceiling using wire rope.



### SUSTAINABILITY

PET panels manufactured from 100% polyester fibre, containing a minimum of 75% post-consumer recycled PET sourced from recycled plastic bottles. Galvanised steel components are durable and recyclable, contributing to long service life and reduced environmental impact. The protective zinc coating extends the material's lifespan and supports sustainable use.



### NON TOXIC

Tested according to BS EN 717-1 (E0) for formaldehyde emissions. The PET panels contain no chemical binders or formaldehyde, supporting safer indoor air quality. Galvanised steel is a stable material that does not release harmful substances under normal indoor conditions, supporting safe indoor environments.



### FLAME RETARDANT

PET panels rated Class B-s1, d0 according to EN 13501-1, offering high fire safety performance for walls and ceilings. Galvanised steel is a non-combustible material, providing reliable fire resistance for use in wall and ceiling systems.



### MAINTENANCE

PET Panels can be cleaned easily using a dust broom, vacuum cleaner, or a damp cloth. Galvanised steel surfaces require minimal maintenance and can be cleaned with a soft cloth and mild cleaning agents to preserve their protective coating and appearance.



## SOUND ABSORPTION

### PET MATERIAL 12mm

Sound class D ( $\alpha_w=0.30$ ) [according to ISO 354:2003 & ISO 11654:1997]

Absorption coefficient measurements

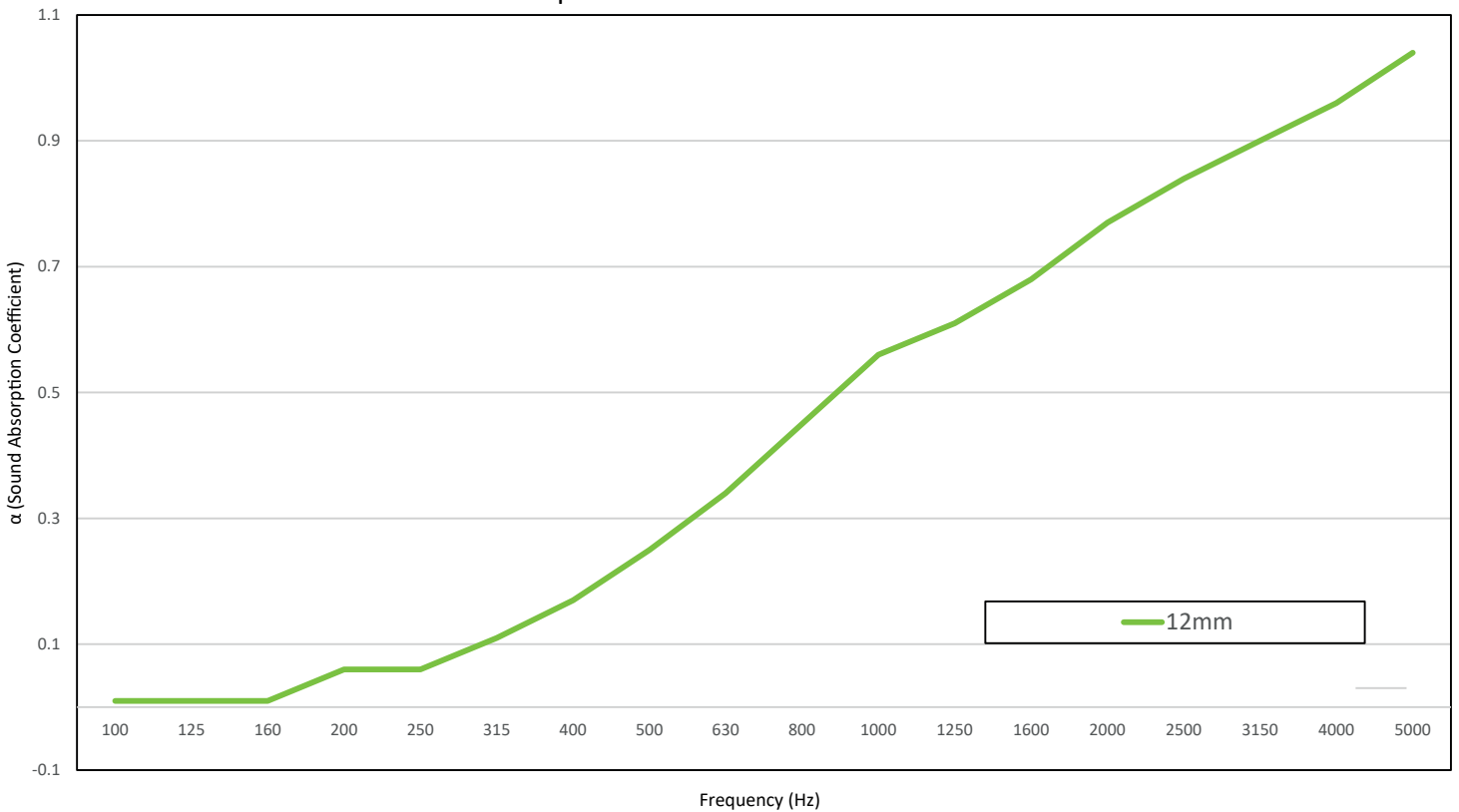

Frequency (Hz)	100	125	160	200	250	315	400	500	630	800	1000	1250	1600	2000	2500	3150	4000	5000
$\alpha_s$ 12mm	0.01	0.01	0.01	0.06	0.06	0.11	0.17	0.25	0.34	0.45	0.56	0.61	0.68	0.77	0.84	0.9	0.96	1.04
	0.01			0.08			0.25			0.54			0.76			0.97		

**STANDARD DIMENSIONS  
AND TYPES**

Bottom view

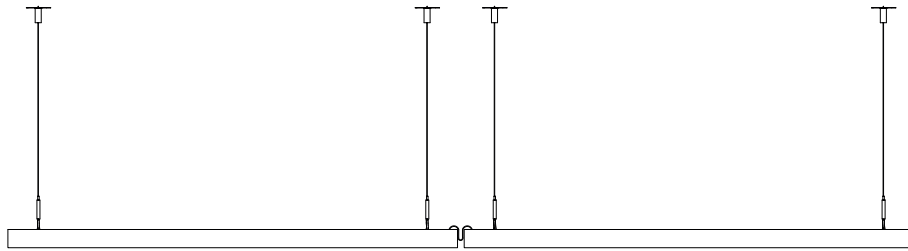
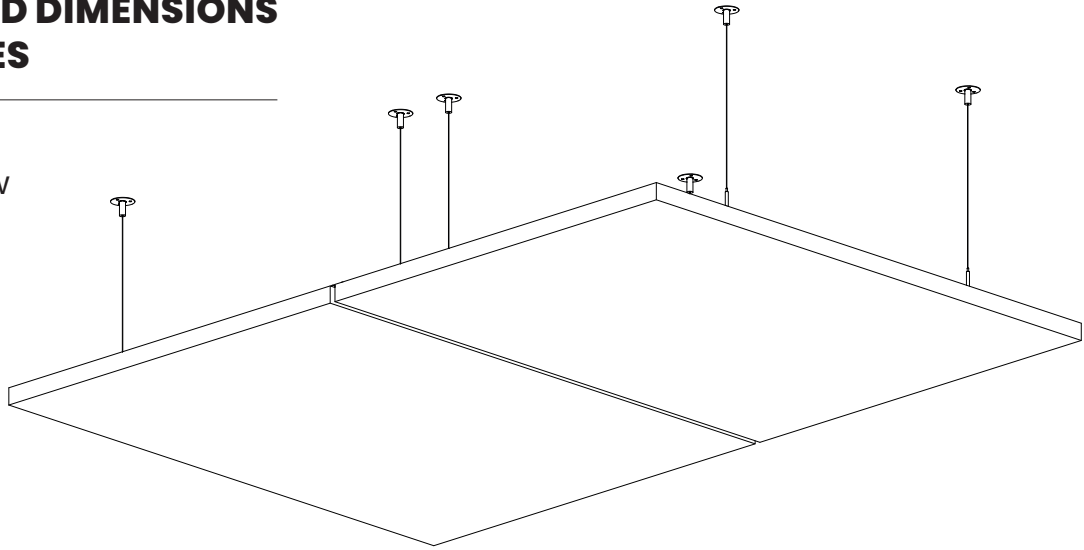

Side view

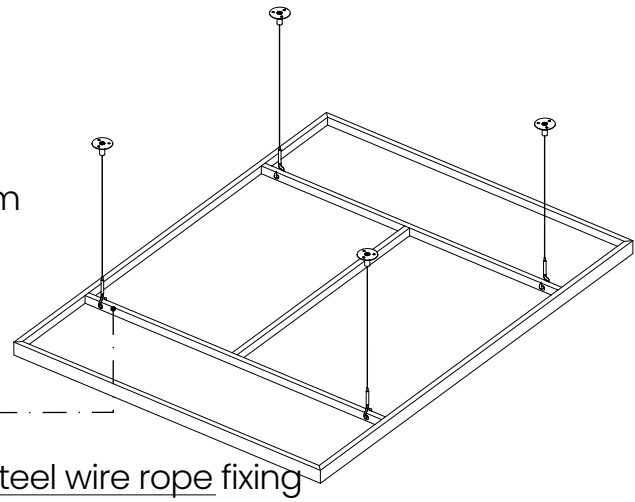
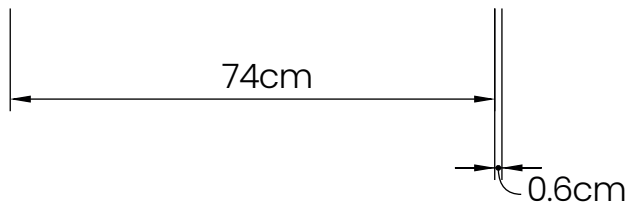

Steel wire rope fixing

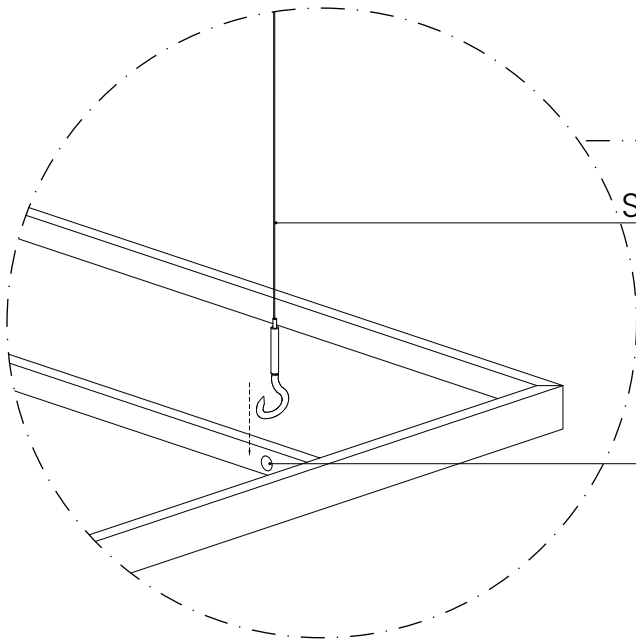

Hanger hole

**STANDARD DIMENSIONS  
AND TYPES**

Top view

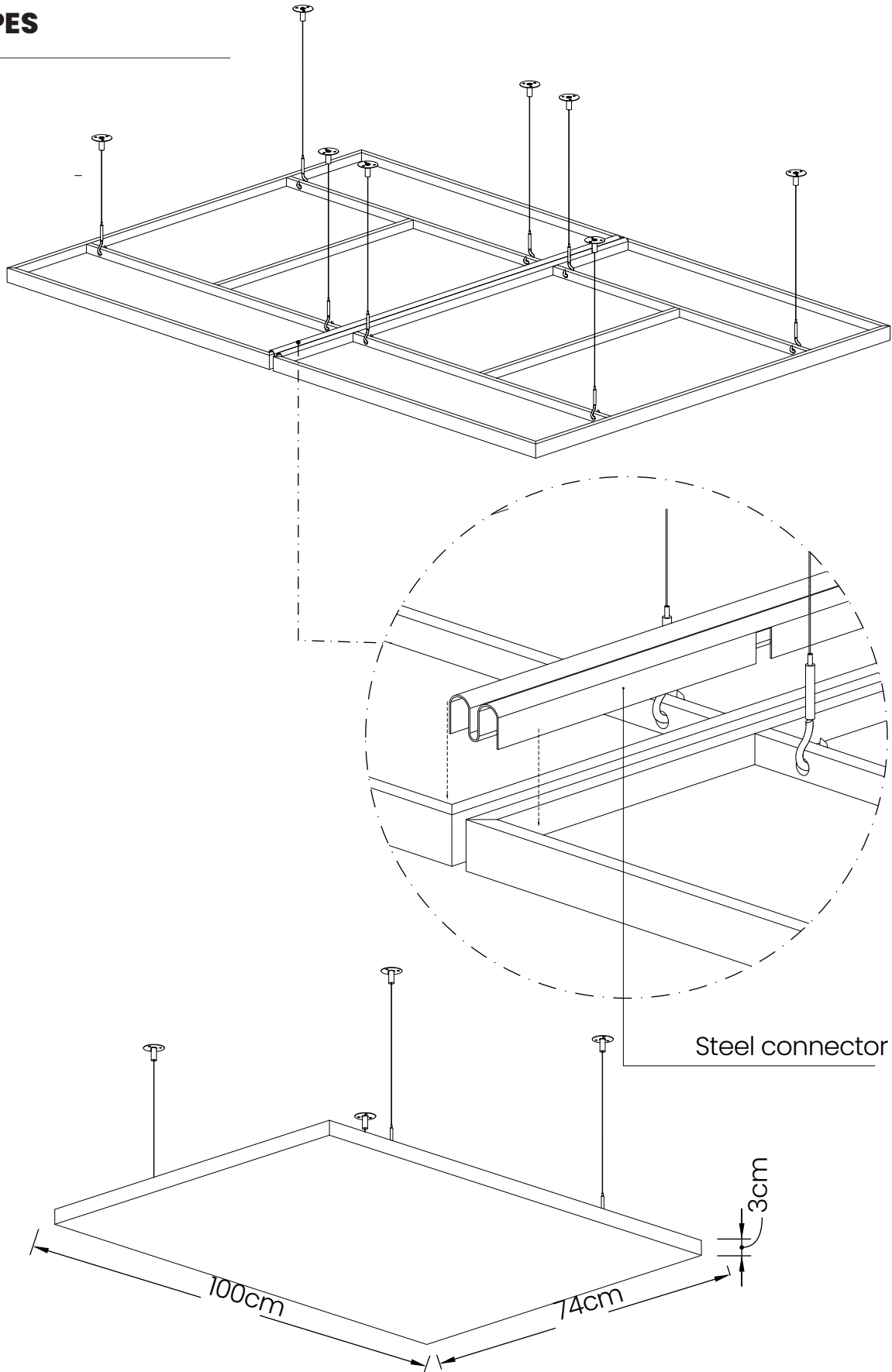

A close-up photograph of vertical acoustic panels. The panels are light-colored with a fine, woven texture. The lighting is soft and even, highlighting the vertical ridges and valleys of the panels. A black rectangular label with the word 'BEAM' in white capital letters is positioned in the top right corner.

**BEAM**

A photograph of an office interior. The wall is covered in vertical acoustic panels. To the left, there is a wooden desk with a black office chair, a laptop, and some papers. In the background, a glass-walled meeting room is visible. A black rectangular label with the word 'BUBBLE' in white capital letters is positioned in the top right corner.

**BUBBLE**

A close-up photograph of vertical acoustic panels, similar to the first image. The lighting is more dramatic, with several recessed ceiling lights visible at the top, casting shadows and highlighting the texture of the panels. A black rectangular label with the word 'NOISY' in white capital letters is positioned in the top right corner.

**NOISY**

## EXTRUDED

---

EXTRUDED acoustic panels are manufactured from recycled PET, offering an environmentally responsible solution for enhancing acoustic comfort. Designed for installation on both walls and ceilings, these panels deliver high sound absorption while elevating the visual character of interior spaces.

Suitable for a wide range of environments—including residential, commercial, and specialized applications—EXTRUDED panels combine reliable acoustic performance with modern design flexibility.

Available in three distinct shapes and formats, the panels are engineered for seamless edge-to-edge installation without visible joints. This allows for the creation of continuous, uniform surfaces across walls and ceilings, resulting in a clean and refined architectural finish.

EXTRUDED panels provide a visually striking solution for wall and ceiling coverings, balancing acoustic efficiency, design versatility, and cost-effectiveness—making them an ideal choice for contemporary interior projects.

**BEAM**



---

## AVAILABLE SIZES

---

### MODULE SIZE

240 cm x 60 cm

### STRIP HEIGHT

7.2 cm

### STRIP THICKNESS

2.5 cm

### GAP BETWEEN BAFFLES

5 cm

### THICKNESS OF BAFFLES

12 mm

---

## MATERIALS AND COLORS

---

### MATERIALS

Polyester Fiber: 100% made from recycled PET.

### COLORS

Refer to Polyester Color Palette at page 179.

---

## TECHNICAL SPECIFICATIONS

---



### INSTALLATION

Installation can be carried out by adhesive bonding to walls or ceilings.



### SUSTAINABILITY

Panels manufactured from 100% polyester fibre, containing a minimum of 75% post-consumer recycled PET sourced from recycled plastic bottles.



### NON TOXIC

Tested according to BS EN 717-1 (E0) for formaldehyde emissions. The panels contain no chemical binders or formaldehyde, supporting safer indoor air quality.



### FLAME RETARDANT

Panels rated Class B-s1, d0 according to EN 13501-1, offering high fire safety performance for walls and ceilings.



### MAINTENANCE

Panels can be cleaned easily using a dust broom, vacuum cleaner, or a damp cloth.



## SOUND ABSORPTION

### MODULAR PET MATERIAL

Sound class D ( $\alpha_w=0.30$ ) [according to ISO 354:2003 & ISO 11654:1997]

Absorption coefficient measurements

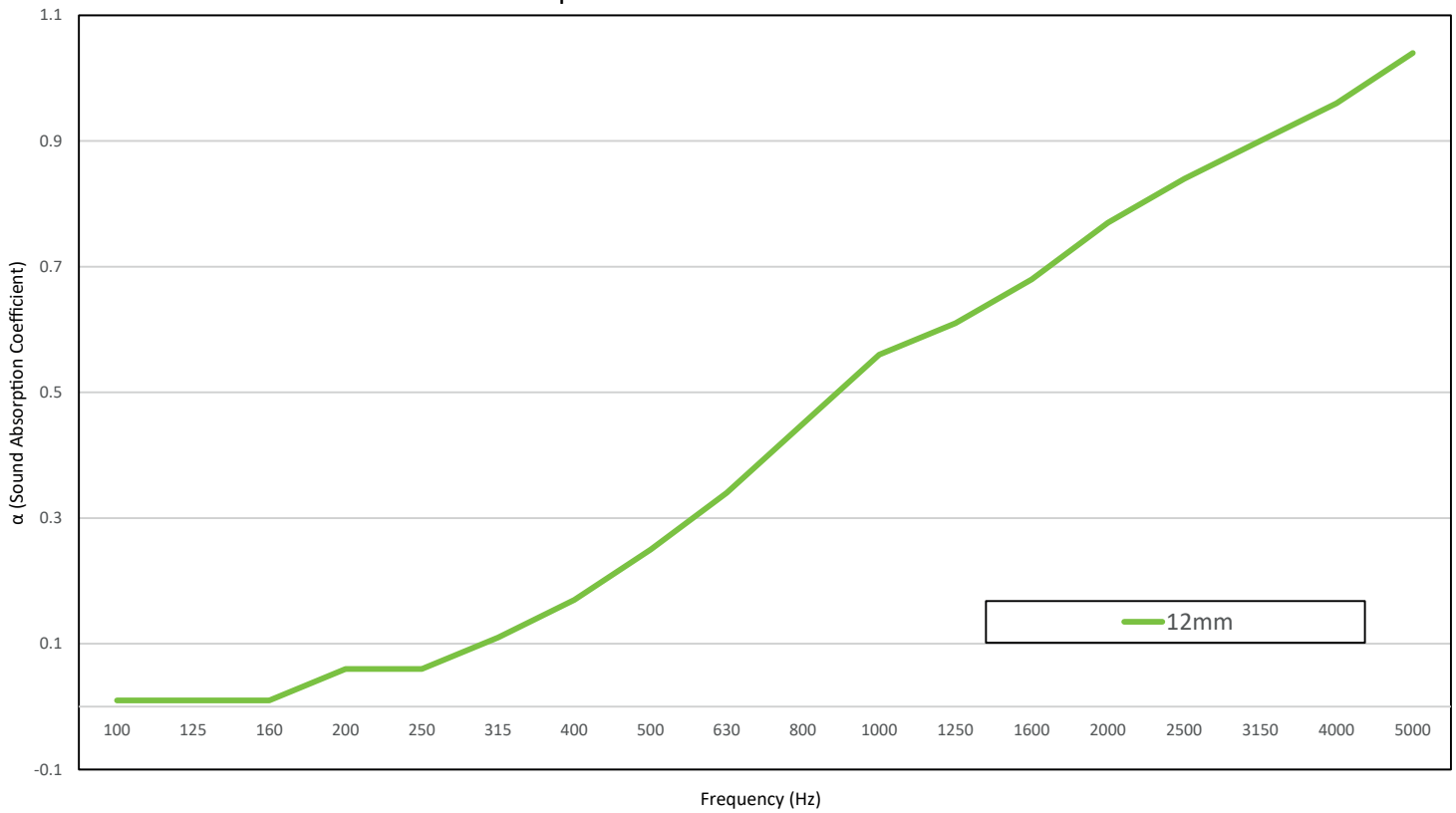

Frequency (Hz)	100	125	160	200	250	315	400	500	630	800	1000	1250	1600	2000	2500	3150	4000	5000
$\alpha_s$ 12mm	0.01	0.01	0.01	0.06	0.06	0.11	0.17	0.25	0.34	0.45	0.56	0.61	0.68	0.77	0.84	0.9	0.96	1.04
	0.01			0.08			0.25			0.54			0.76			0.97		



**STANDARD DIMENSIONS  
AND TYPES**

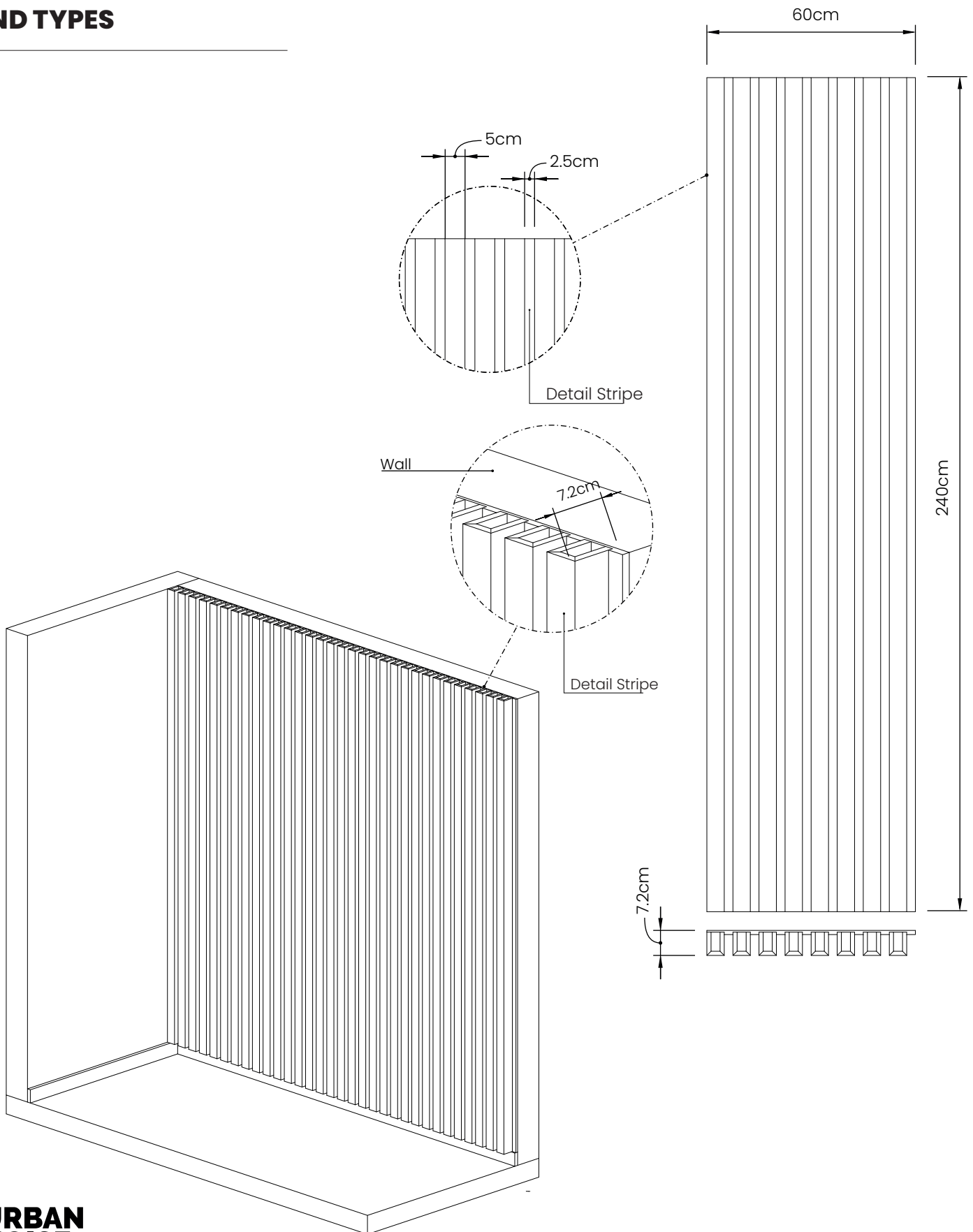

**BUBBLE**



## AVAILABLE SIZES

### MODULE SIZE

240 cm x 60 cm

### STRIP HEIGHT

4.7 cm

### STRIP THICKNESS

5 cm

### THICKNESS OF BAFFLES

12 mm

## MATERIALS AND COLORS

### MATERIALS

Polyester Fiber: 100% made from recycled PET.

### COLORS

Refer to Polyester Color Palette at page 179.

## TECHNICAL SPECIFICATIONS



### INSTALLATION

Installation can be carried out by adhesive bonding to walls or ceilings.



### SUSTAINABILITY

Panels manufactured from 100% polyester fibre, containing a minimum of 75% post-consumer recycled PET sourced from recycled plastic bottles.



### NON TOXIC

Tested according to BS EN 717-1 (E0) for formaldehyde emissions. The panels contain no chemical binders or formaldehyde, supporting safer indoor air quality.



### FLAME RETARDANT

Panels rated Class B-s1, d0 according to EN 13501-1, offering high fire safety performance for walls and ceilings.



### MAINTENANCE

Panels can be cleaned easily using a dust broom, vacuum cleaner, or a damp cloth.



## SOUND ABSORPTION

### MODULAR PET MATERIAL

Sound class D ( $\alpha_w=0.30$ ) [according to ISO 354:2003 & ISO 11654:1997]

Absorption coefficient measurements

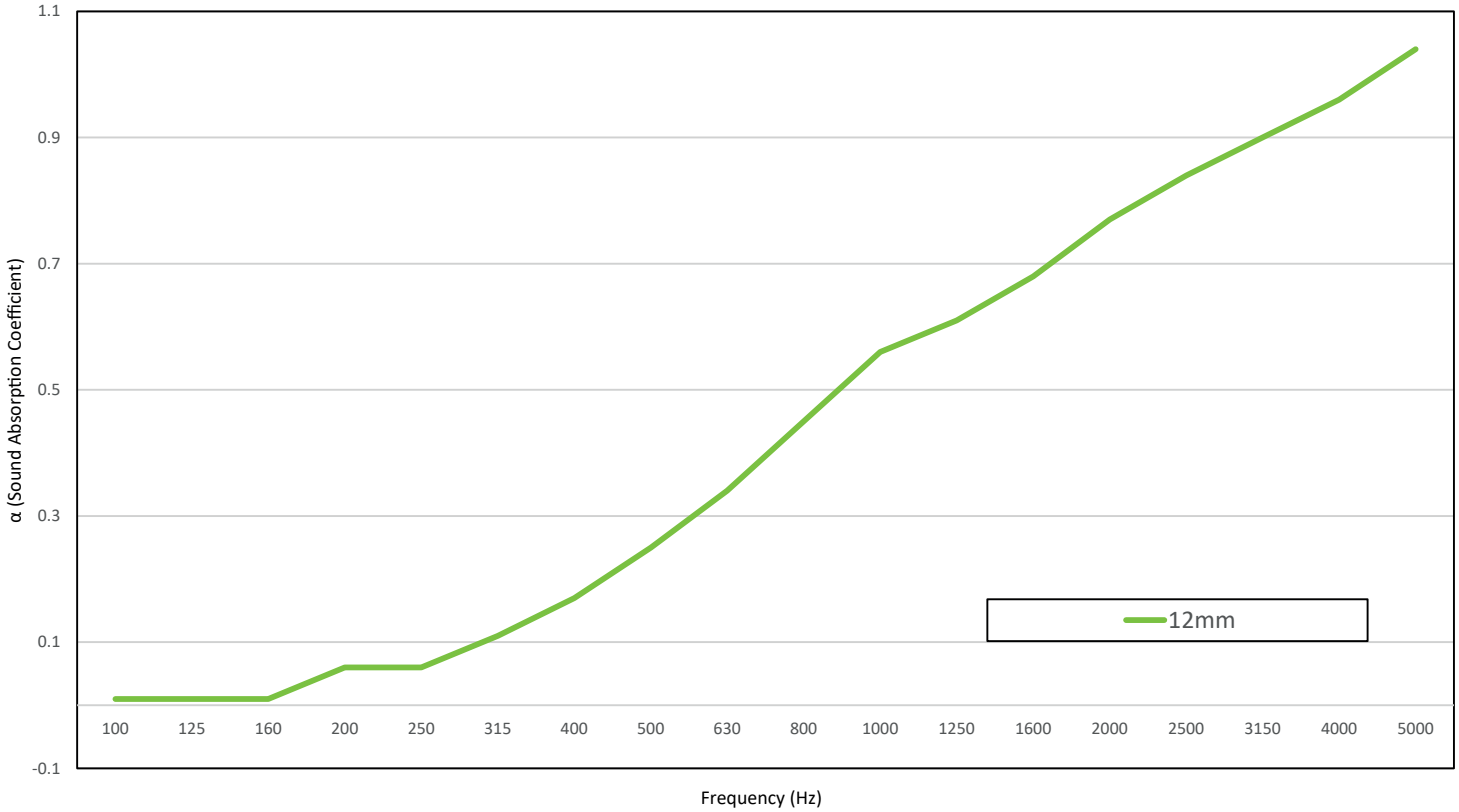

Frequency (Hz)	100	125	160	200	250	315	400	500	630	800	1000	1250	1600	2000	2500	3150	4000	5000
$\alpha_s$	0.01	0.01	0.01	0.06	0.06	0.11	0.17	0.25	0.34	0.45	0.56	0.61	0.68	0.77	0.84	0.9	0.96	1.04
12mm	0.01			0.08			0.25			0.54			0.76			0.97		

**STANDARD DIMENSIONS  
AND TYPES**

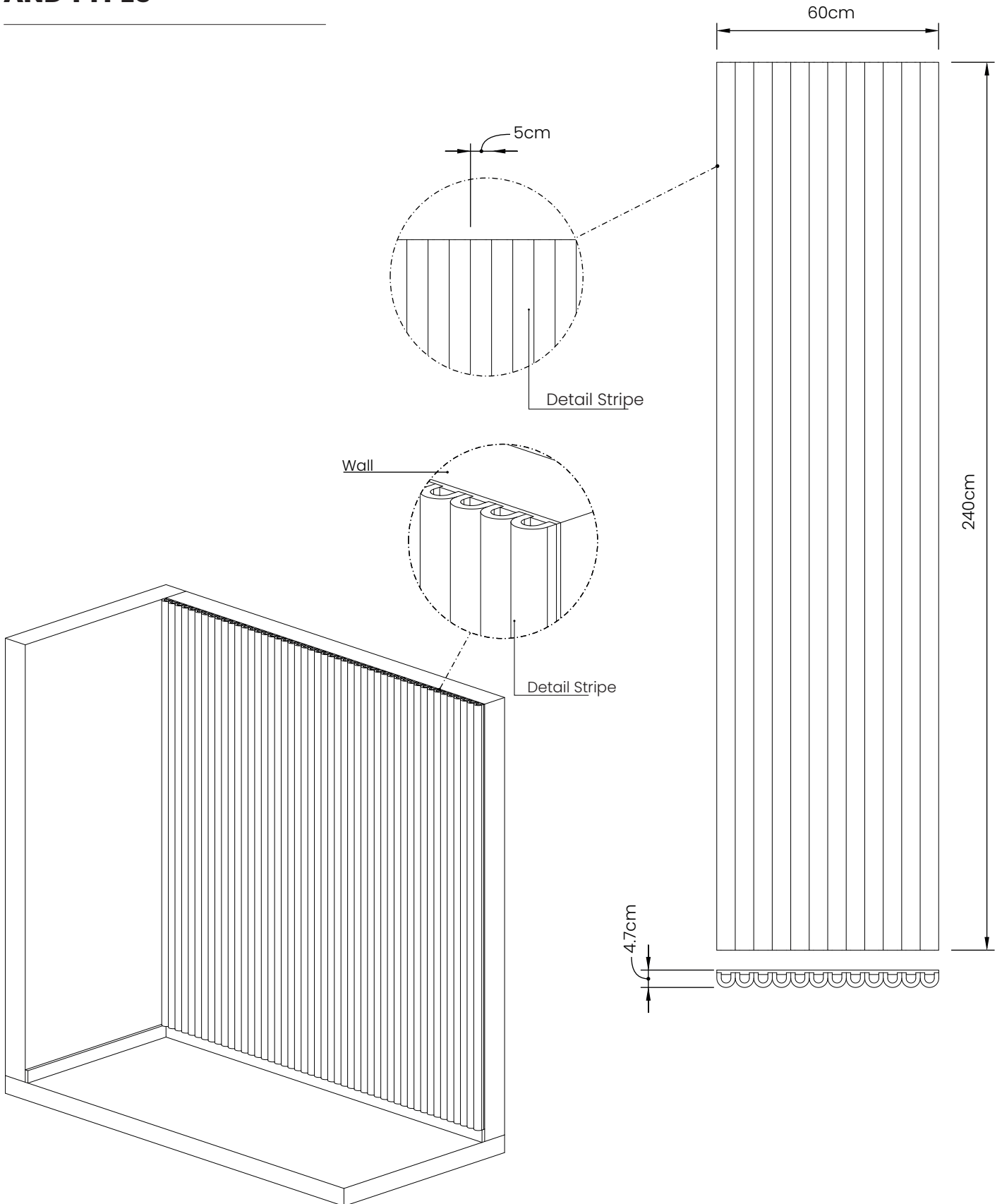

**NOISY**



## AVAILABLE SIZES

### MODULE SIZE

240 cm x 60 cm

### STRIP HEIGHT

4.9 cm

### STRIP THICKNESS

7.5 cm

### THICKNESS OF BAFFLES

12 mm

## MATERIALS AND COLORS

### MATERIALS

Polyester Fiber: 100% made from recycled PET.

### COLORS

Refer to Polyester Color Palette at page 179.

## TECHNICAL SPECIFICATIONS



### INSTALLATION

Installation can be carried out by adhesive bonding to walls or ceilings.



### SUSTAINABILITY

Panels manufactured from 100% polyester fibre, containing a minimum of 75% post-consumer recycled PET sourced from recycled plastic bottles.



### NON TOXIC

Tested according to BS EN 717-1 (E0) for formaldehyde emissions. The panels contain no chemical binders or formaldehyde, supporting safer indoor air quality.



### FLAME RETARDANT

Panels rated Class B-s1, d0 according to EN 13501-1, offering high fire safety performance for walls and ceilings.



### MAINTENANCE

Panels can be cleaned easily using a dust broom, vacuum cleaner, or a damp cloth.

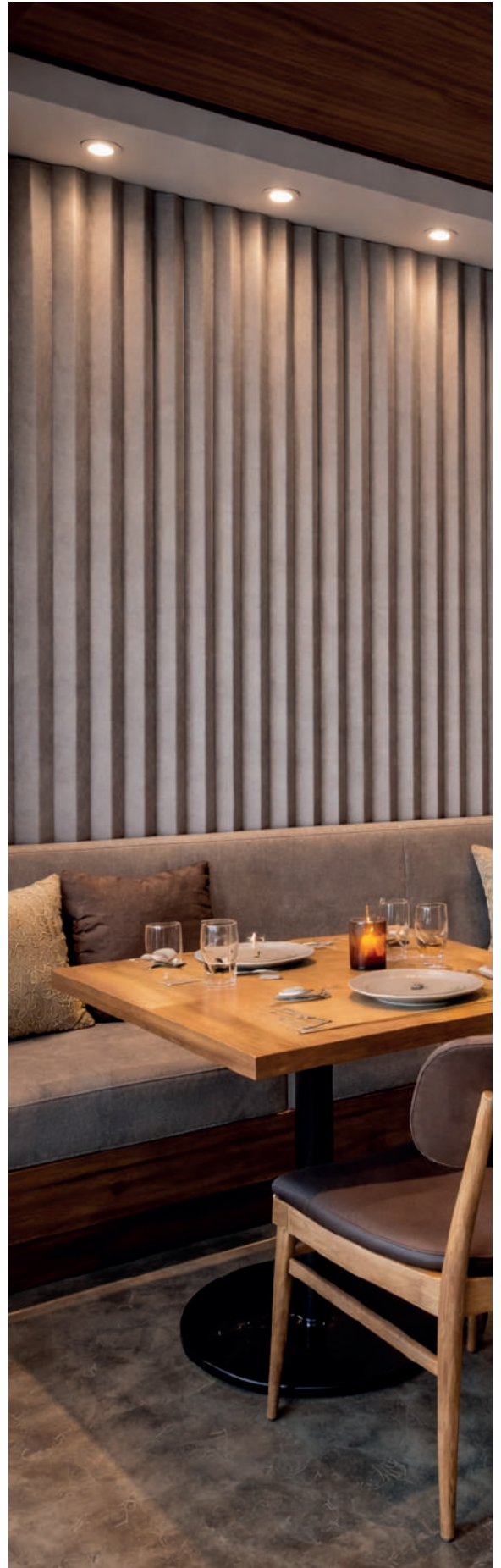

## SOUND ABSORPTION

### MODULAR PET MATERIAL

Sound class D ( $\alpha_w=0.30$ ) [according to ISO 354:2003 & ISO 11654:1997]

Absorption coefficient measurements

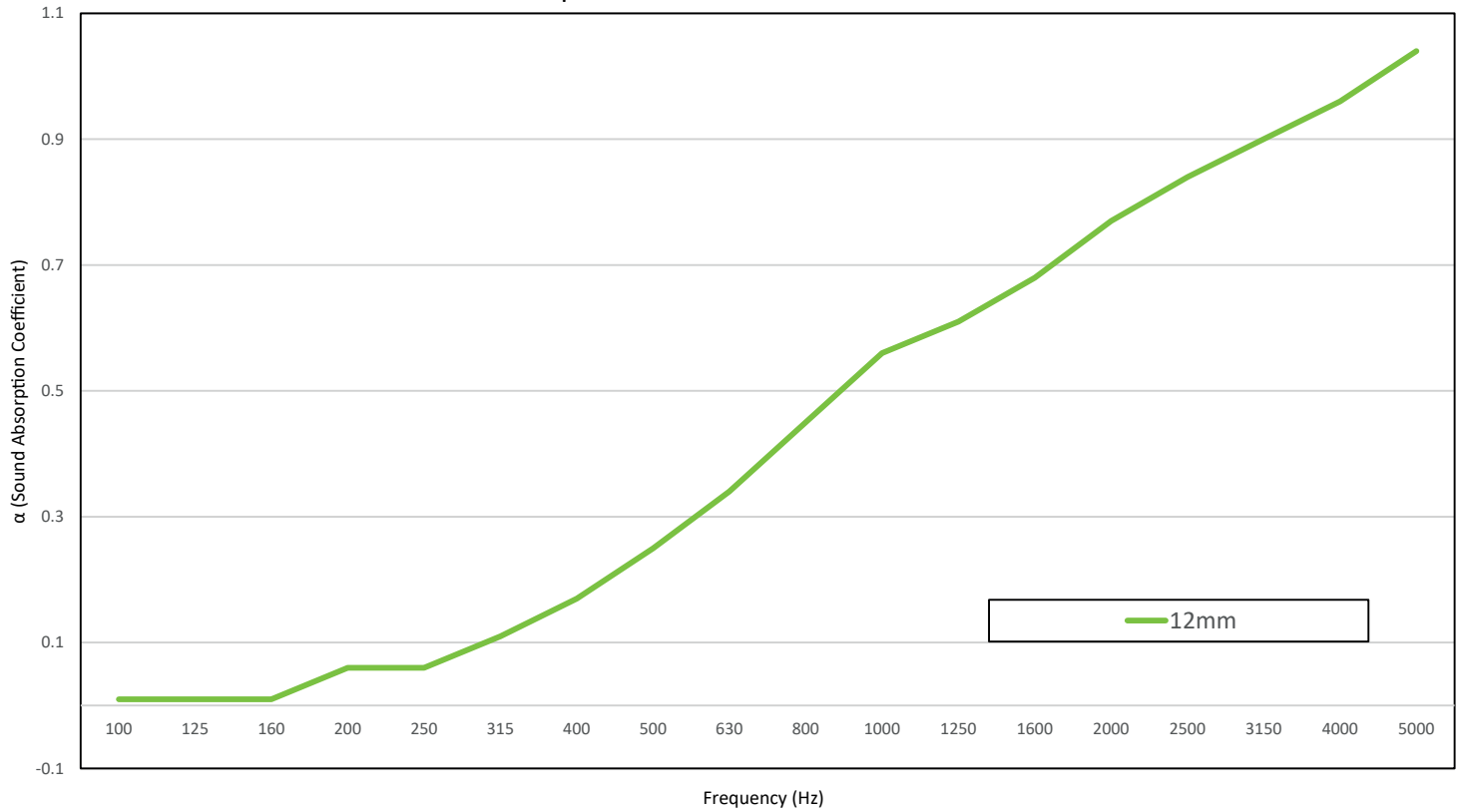

Frequency (Hz)	100	125	160	200	250	315	400	500	630	800	1000	1250	1600	2000	2500	3150	4000	5000
$\alpha_w$	0.01	0.01	0.01	0.06	0.06	0.11	0.17	0.25	0.34	0.45	0.56	0.61	0.68	0.77	0.84	0.9	0.96	1.04
12mm	0.01			0.08			0.25			0.54			0.76			0.97		

## STANDARD DIMENSIONS AND TYPES

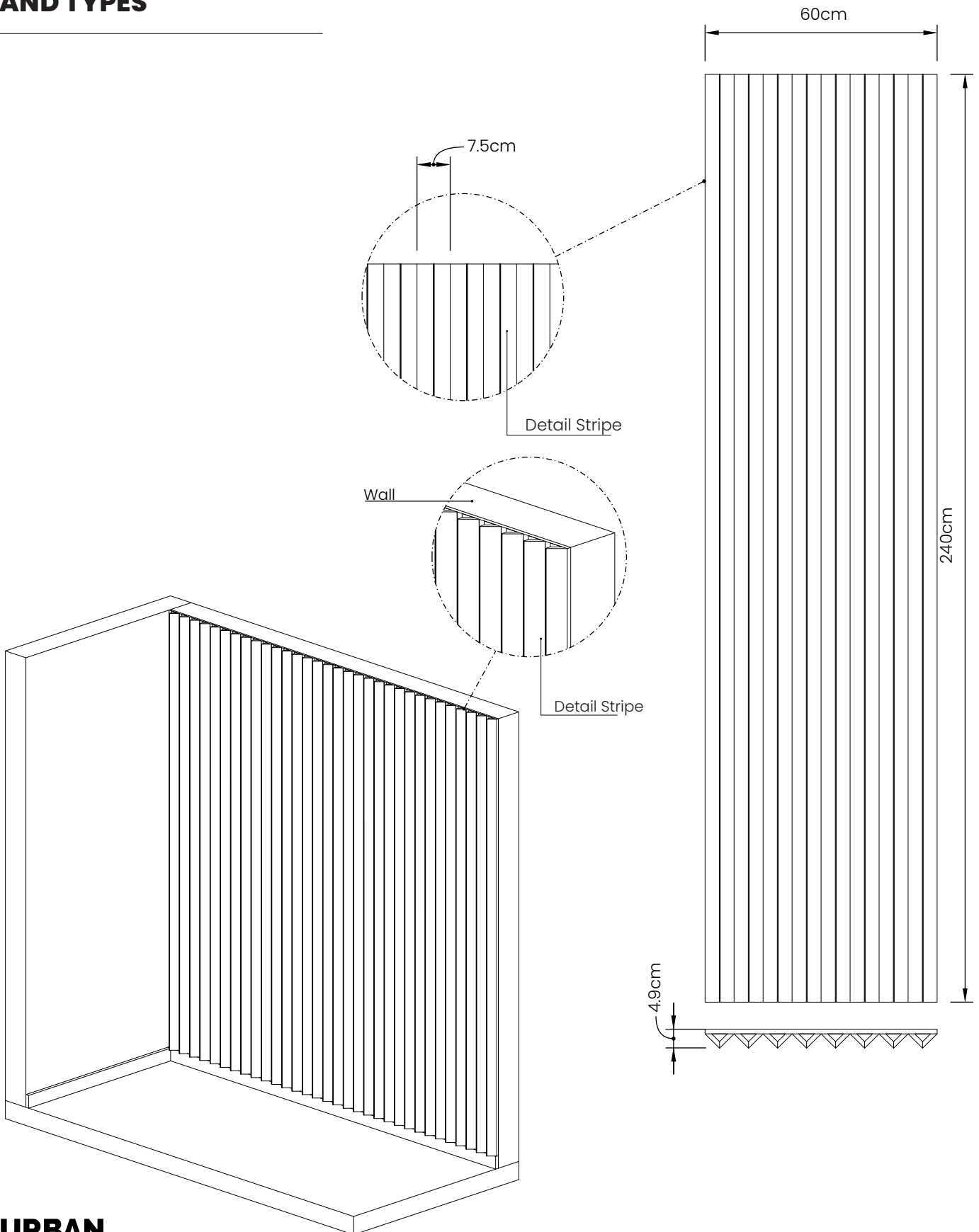



## STAND ALONES

---

Excessive noise is a recognized environmental factor that can negatively impact occupant well-being, concentration, and productivity. In open-plan spaces, effective acoustic control is essential to ensure comfort and speech privacy. Acoustic screens provide an efficient solution for reducing noise transmission while maintaining spatial flexibility.

The UNC Standalone 401 and 403 systems feature a durable timber frame with a high-density mineral wool core, delivering reliable sound absorption performance. They are upholstered with specialized acoustic textile and supported by a powder-coated steel base for stability and longevity.

A wide selection of fabric finishes, base colours, and dimensions allows for customization to meet both acoustic and design requirements.

## AVAILABLE SIZES

### STANDALONE 401

**DIMENSIONS (H x L x W)**  
180 x 80 x 4.2 cm

**INSTALLATION**

Panel inserted into a steel base for stable freestanding support.

### STANDALONE 403S

**DIMENSIONS (H x L x W)**  
180 x 80 x 4.8 cm

**INSTALLATION**

Panel inserted into a steel base for enhanced stability.

### STANDALONE 403D

**DIMENSIONS (H x L x W)**  
180 x 80 x 5.4 cm

**INSTALLATION**

Side-mounted steel supports with locking screws for secure positioning.

## MATERIALS AND COLORS

### MATERIALS

Polyester fibre, manufactured from recycled PET, ensuring durability and an environmentally responsible solution.

### COLORS

Refer to Fabric Color Palette at page 181.

## TECHNICAL SPECIFICATIONS



### INSTALLATION

Installation is achieved by sliding the unit into a steel base or lateral steel support and securing it with locking screws.



### SUSTAINABILITY (FABRIC)

The upholstery fabric is certified according to the Global Recycled Standard (GRS), verifying the significant use of recycled materials. It is manufactured entirely PVC-free, with a continuously increasing proportion of recycled polyester in its composition.



### CERTIFICATIONS (FABRIC)

Sanitized®, OEKO-TEX®, CE, VOC, Indoor Air Comfort (IAC) Gold®, REACH compliant, DIN EN standards, PVC-free, GRS certified.



### FIRE PERFORMANCE (FABRIC)

Class B-s1, d0 in accordance with EN 13501-1.



### MAINTENANCE (FABRIC)

The fabric surface can be easily maintained using a clothes brush, microfiber cloth, or rubber eraser to remove dust and minor marks.

## ACOUSTICS

### SOUND ABSORPTION

Class A ( $\alpha_w=0.90$ ) [according to DIN EN ISO 354]

### IN-SITU ATTENUATION

DPa=6-10dB [according to BS EN ISO 11821]

Absorption coefficient measurements

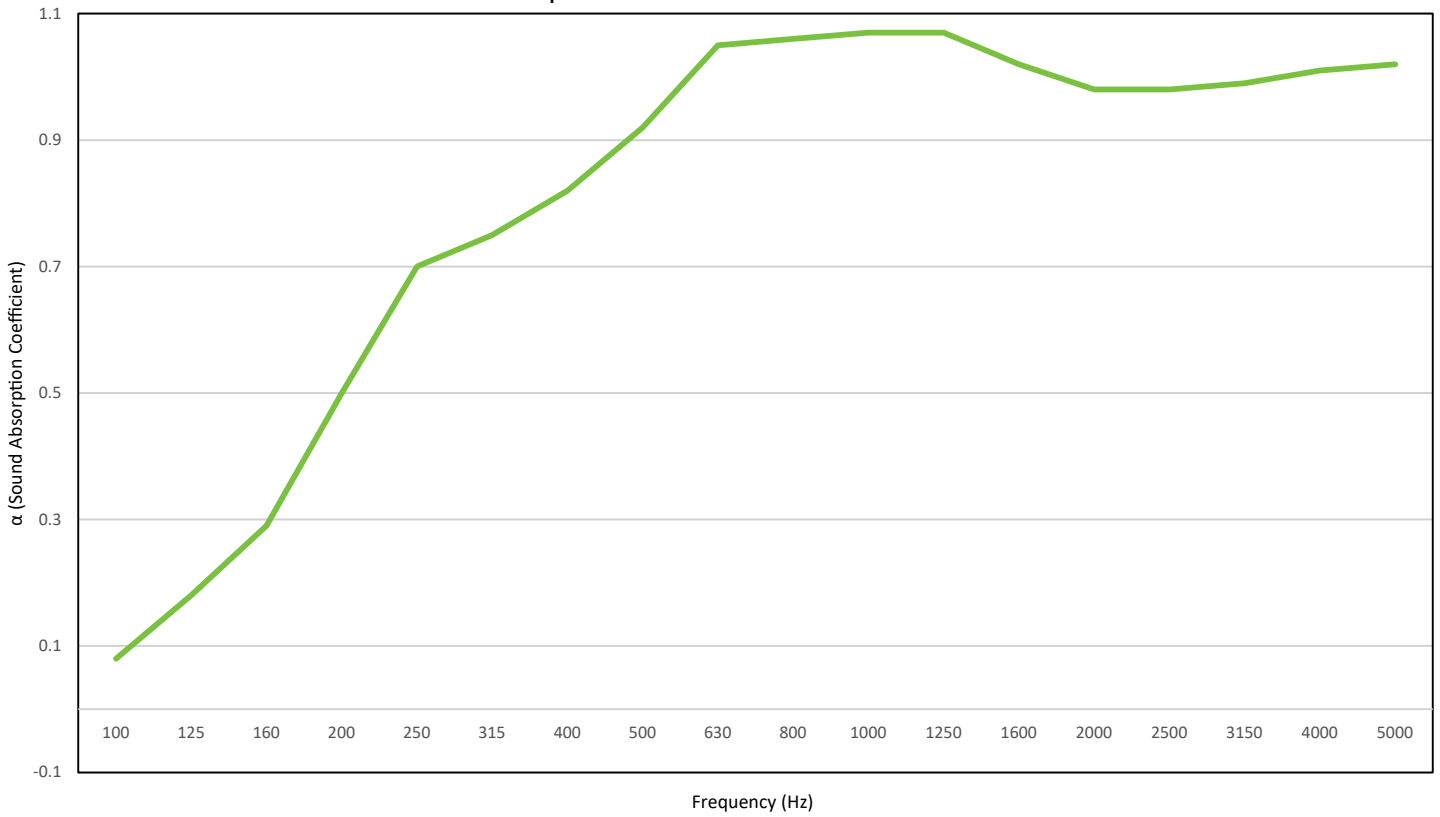

Frequency (Hz)	100	125	160	200	250	315	400	500	630	800	1000	1250	1600	2000	2500	3150	4000	5000
as	0.08	0.18	0.29	0.5	0.7	0.75	0.82	0.92	1.05	1.06	1.07	1.07	1.02	0.98	0.98	0.99	1.01	1.02
	0.18		0.65			0.93			1.07			0.99			1.01			



**STANDARD DIMENSIONS AND TYPES**

**STANDALONE 401**

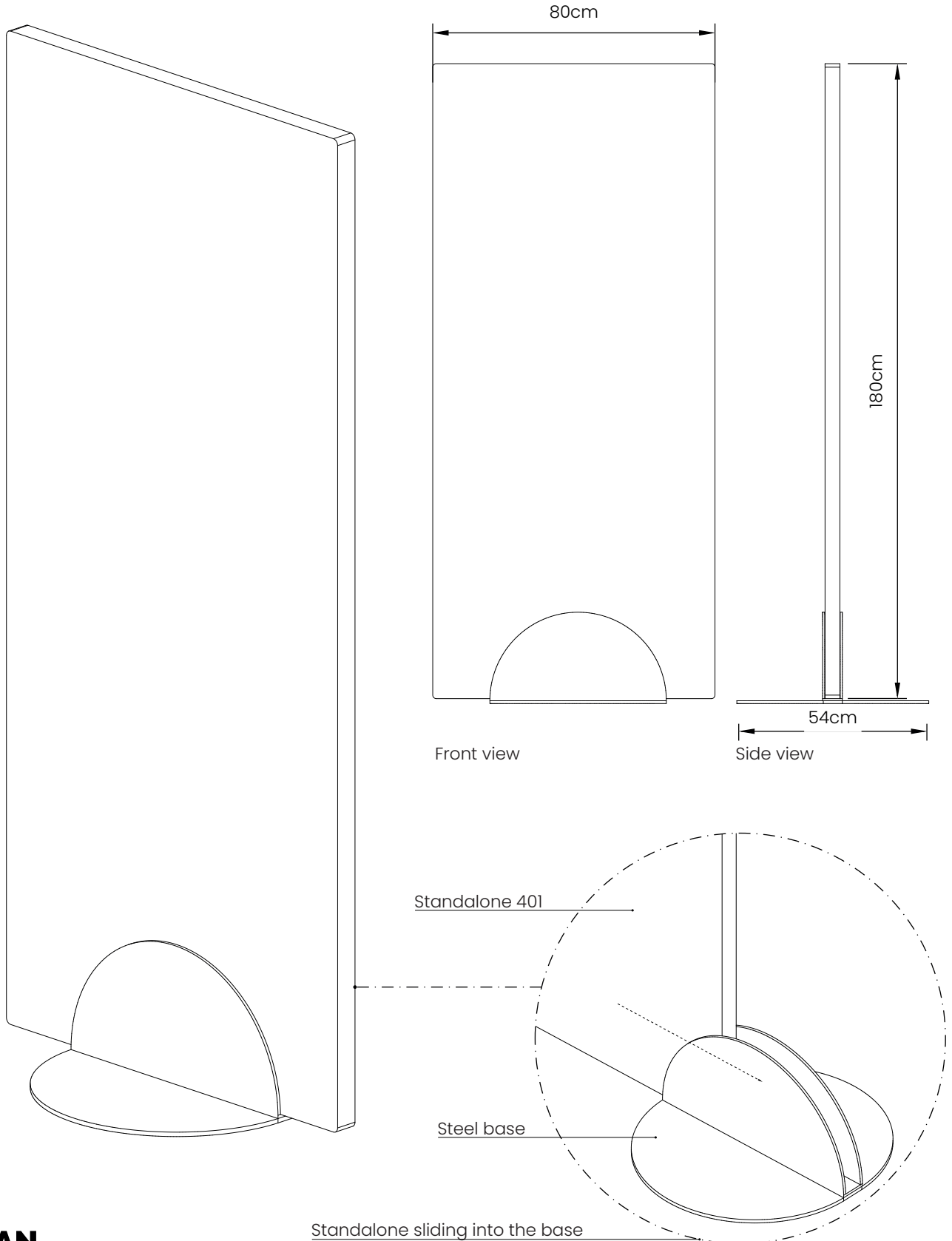



**STANDARD DIMENSIONS AND TYPES**

**STANDALONE 403S**

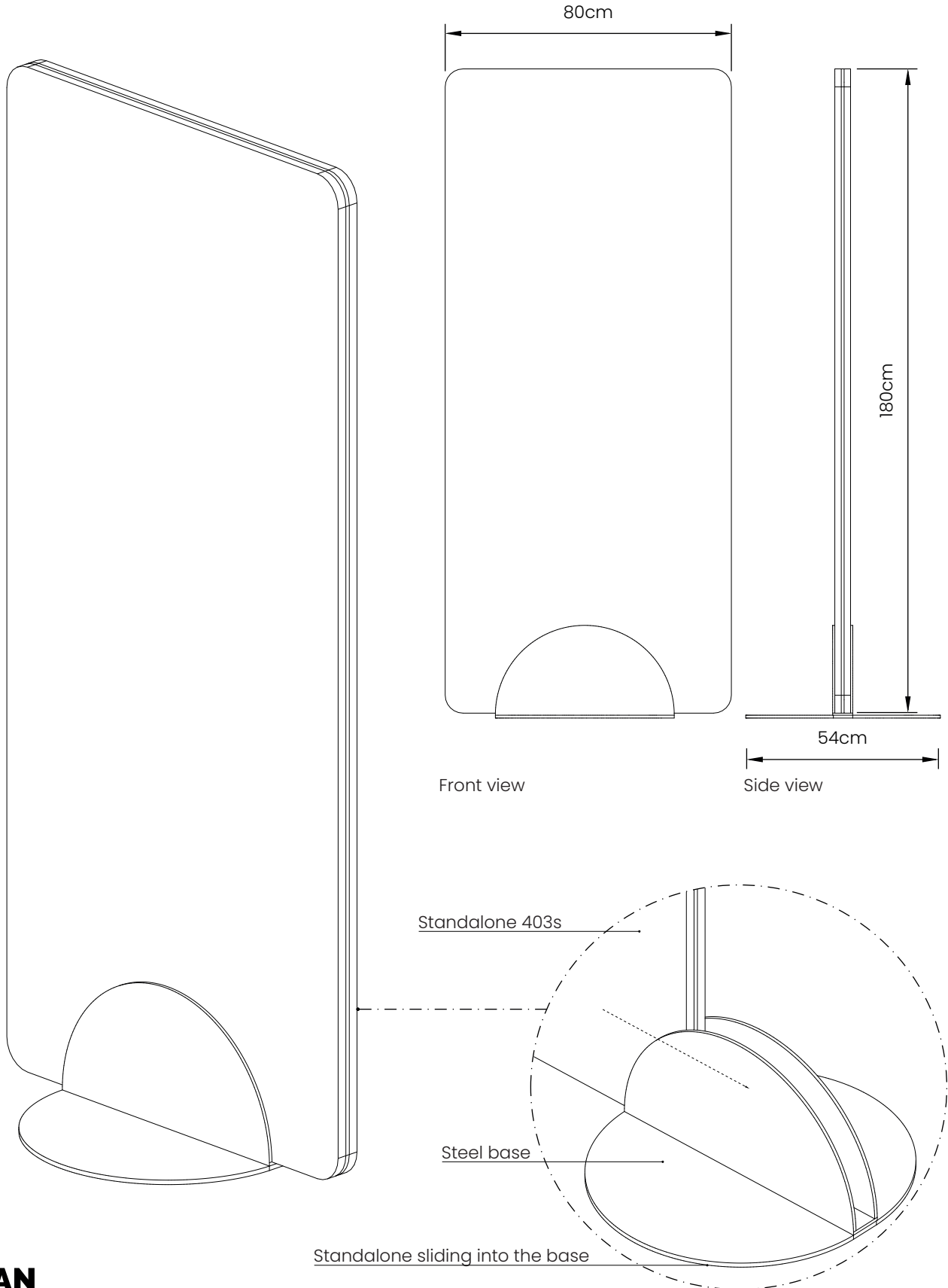



## STANDARD DIMENSIONS AND TYPES

### STANDALONE 403D

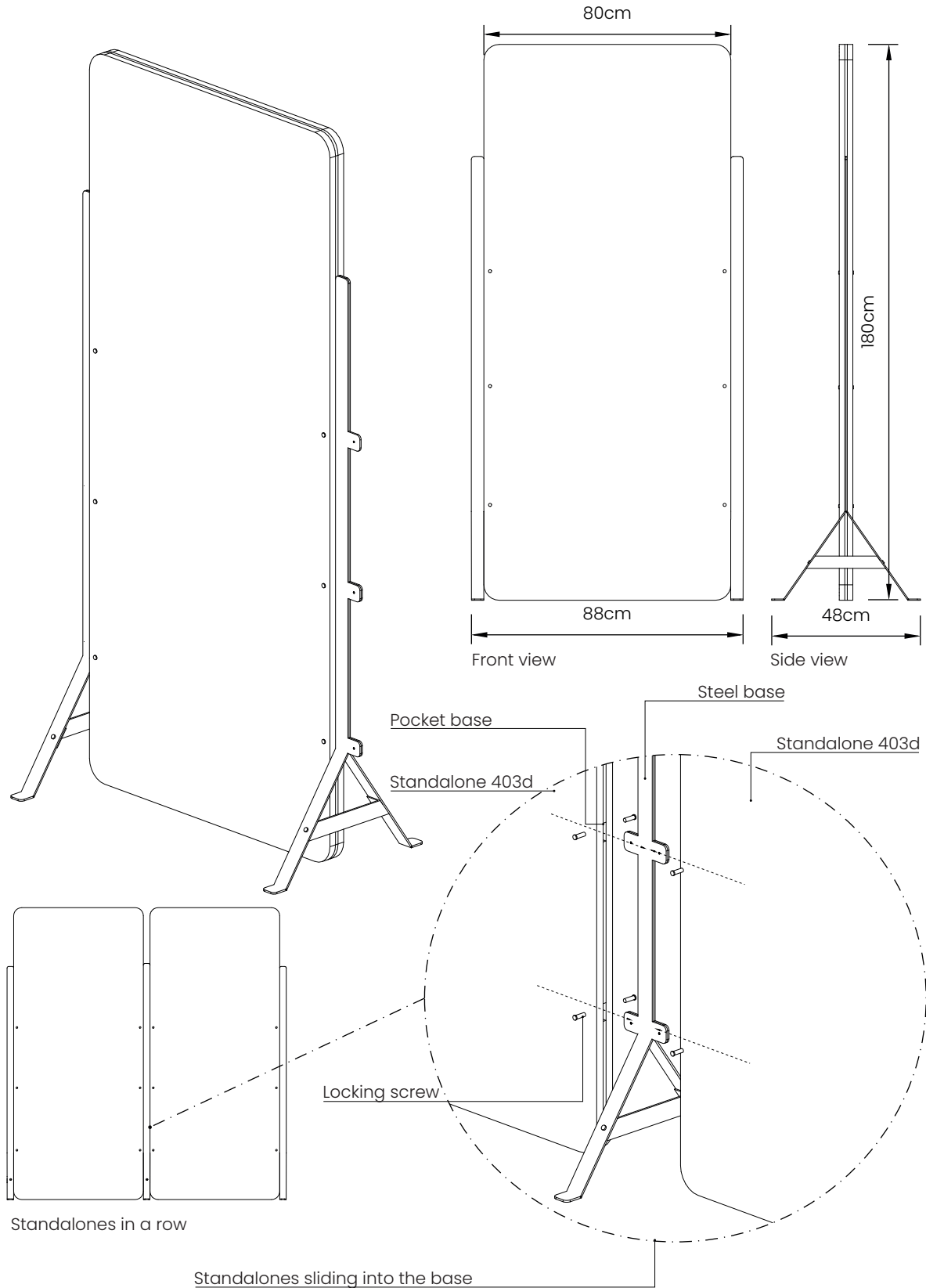



## DESK DIVIDERS

---

Noise is widely defined as unwanted sound, and elevated background noise levels can significantly impact both productivity and occupant well-being. In modern open-plan office environments, effective acoustic control is essential to ensure comfort, concentration, and speech privacy. Acoustic screens represent a primary solution for mitigating noise transmission while enhancing spatial separation.

UNC Desk Dividers 301 & 303 are engineered to deliver high acoustic performance alongside refined aesthetics. Each unit features a robust wooden frame, an internal core of high-density mineral wool (rockwool) for optimal sound absorption, and a specialised acoustic textile finish designed to improve sound attenuation while maintaining visual appeal. The system is supported by a durable, powder-coated metal base for structural stability and long-term use.

A wide selection of fabric colours, base finishes, and dimensional configurations allows for full customization, enabling seamless integration into diverse interior designs while meeting specific project and client requirements.

## AVAILABLE SIZES

### NSCREEN 301

#### DIMENSIONS (H × L × W)

- Option A: 55 cm × 75 cm × 4.2 cm
- Option B: 55 cm × 120 cm × 4.2 cm
- Option C: 55 cm × 140 cm × 4.2 cm
- Option D: 55 cm × 160 cm × 4.2 cm

#### CONNECTOR TYPES\*

- L Connector
- T Connector
- Cross Connector
- I Connector

### NSCREEN 303

#### DIMENSIONS (H × L × W)

- Option A: 55 cm × 75 cm × 4.7 cm
- Option B: 55 cm × 120 cm × 4.7 cm
- Option C: 55 cm × 140 cm × 4.7 cm
- Option D: 55 cm × 160 cm × 4.7 cm

#### CONNECTOR TYPES\*

- L Connector
- T Connector
- I Connector
- Cross-04 Connector
- Cross-03 Connector

\*These connection solutions allow for modular configurations, supporting linear, corner, and multi-directional workstation arrangements in open-plan environments.

## MATERIALS AND COLORS

### MATERIALS

Polyester fibre, manufactured from recycled PET, ensuring durability and an environmentally responsible solution.

### COLORS

Refer to Fabric Color Palette at page 181.

## TECHNICAL SPECIFICATIONS



### INSTALLATION

Installation is achieved via steel connectors mounted on the desk and secured with locking screws.



### SUSTAINABILITY (FABRIC)

The upholstery fabric is certified according to the Global Recycled Standard (GRS), verifying the significant use of recycled materials. It is manufactured entirely PVC-free, with a continuously increasing proportion of recycled polyester in its composition.



### CERTIFICATIONS (FABRIC)

Sanitized®, OEKO-TEX®, CE, VOC, Indoor Air Comfort (IAC) Gold®, REACH compliant, DIN EN standards, PVC-free, GRS certified.



### FIRE PERFORMANCE (FABRIC)

Class B-s1, d0 in accordance with EN 13501-1.



### MAINTENANCE (FABRIC)

The fabric surface can be easily maintained using a clothes brush, microfiber cloth, or rubber eraser to remove dust and minor marks.



## ACOUSTICS

### SOUND ABSORPTION

Class A ( $\alpha_w=0.90$ ) [according to DIN EN ISO 354]

### IN-SITU ATTENUATION

D<sub>Pa</sub>=6-10dB [according to BS EN ISO 11821]

Absorption coefficient measurements

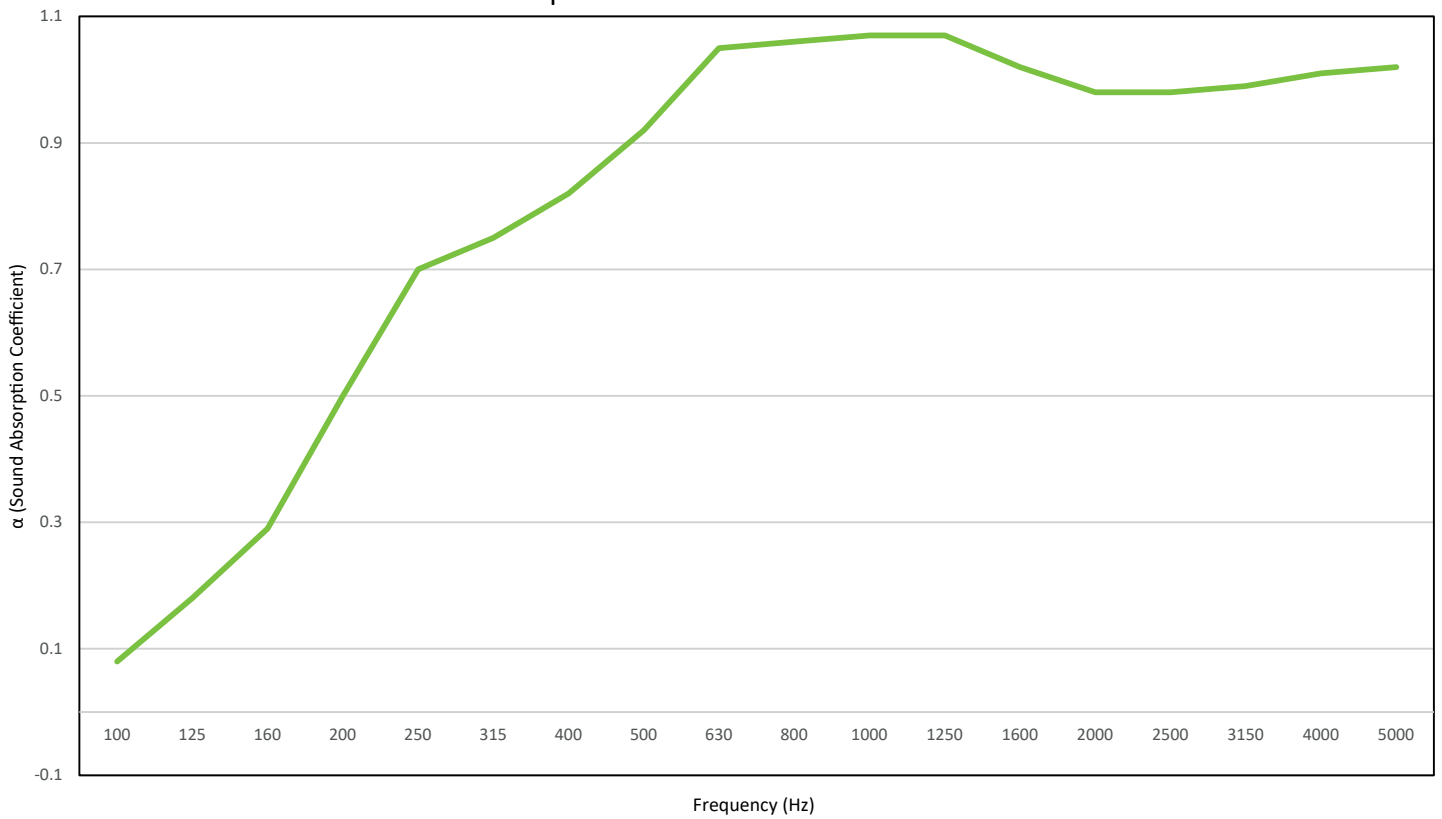

Frequency (Hz)	100	125	160	200	250	315	400	500	630	800	1000	1250	1600	2000	2500	3150	4000	5000
$\alpha_s$	0.08	0.18	0.29	0.5	0.7	0.75	0.82	0.92	1.05	1.06	1.07	1.07	1.02	0.98	0.98	0.99	1.01	1.02
	0.18			0.65			0.93			1.07			0.99			1.01		

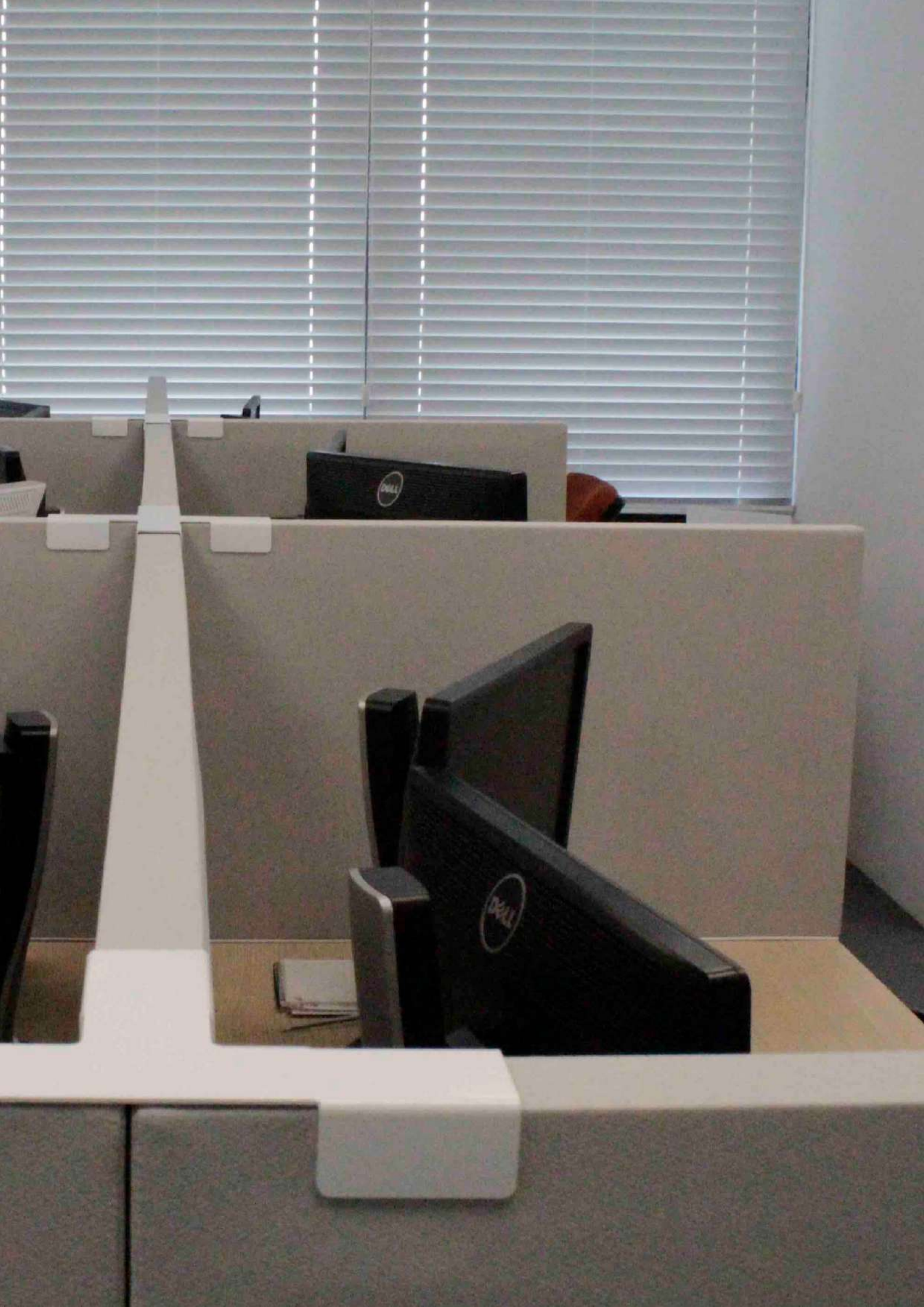

**STANDARD DIMENSIONS AND TYPES**

**NSCREEN 301**

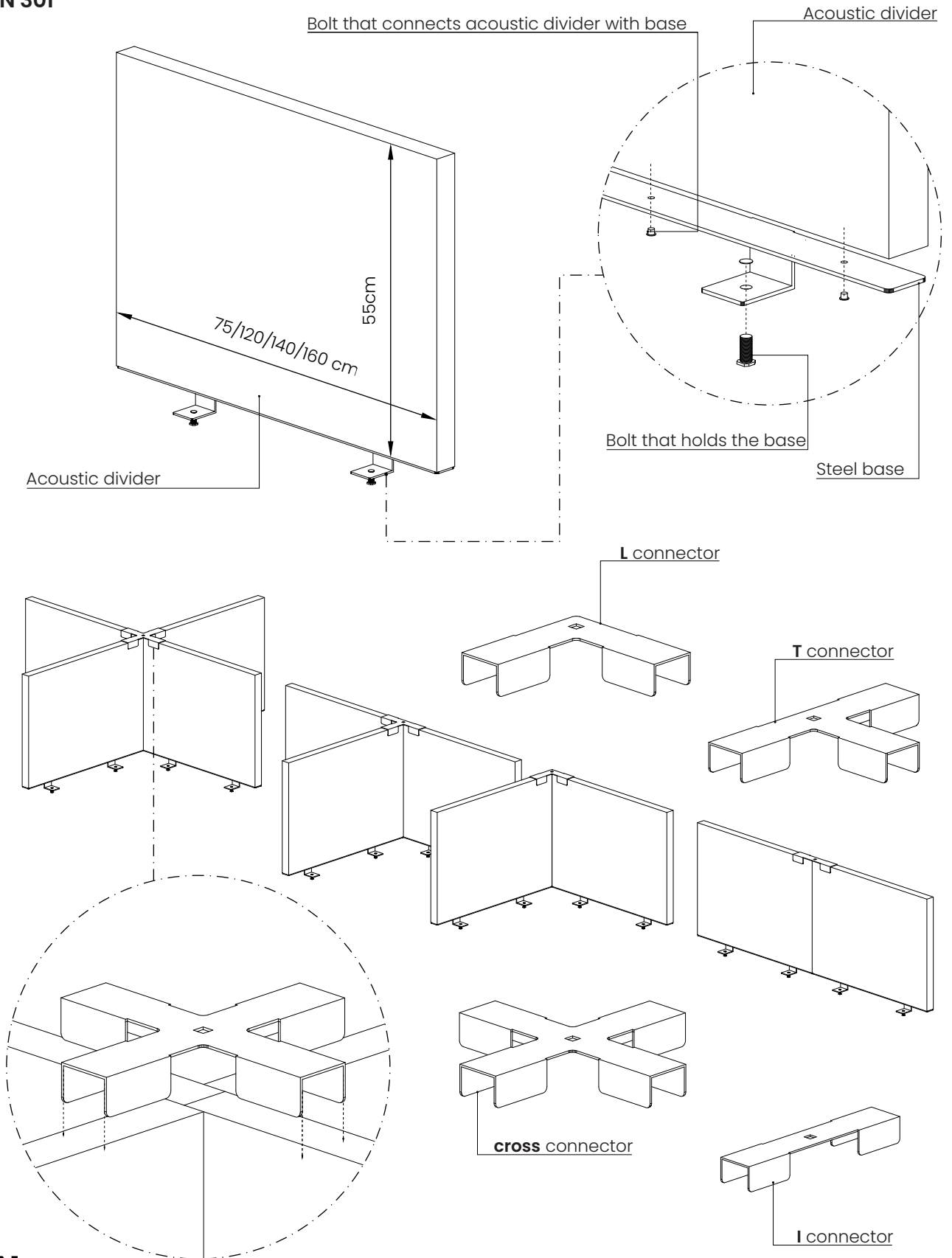



STANDARD DIMENSIONS AND TYPES

NSCREEN 303

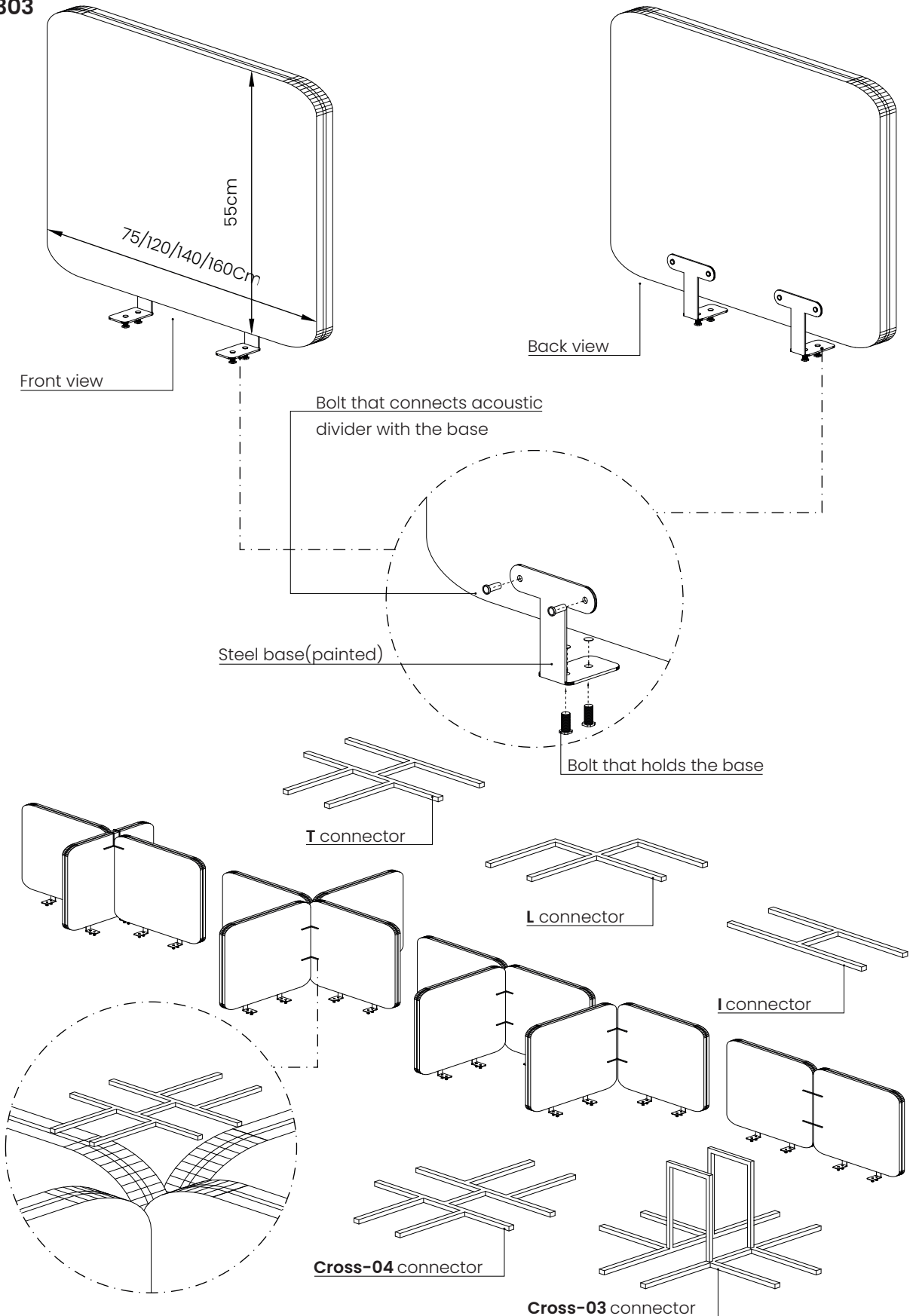



## **BLINDS**

---

Acoustic Vertical **BLINDS** are an ideal solution for spaces with large windows or hard surfaces, where sound control and comfort are essential. Designed to deliver excellent sound absorption and enhanced thermal insulation, they also contribute to a refined and modern aesthetic.

Available in a wide range of colours, these blinds offer exceptional design flexibility, allowing clients and consultants to achieve the perfect visual and functional balance for any interior.

Combining performance with style, **BLINDS** provide a visually striking wall-covering solution that enhances any project—efficiently and cost-effectively.

## AVAILABLE SIZES

### BLIND WIDTH

12.7 cm

### THICKNESS

12 mm

### STANDARD BLINDS HEIGHT

40 – 240 cm

### EXTENDED BLINDS HEIGHT

245 – 300 cm

(featuring a seamless connection for a continuous appearance)

## MATERIALS AND COLORS

### MATERIALS

Polyester fibre, manufactured from recycled PET, ensuring durability and an environmentally responsible solution.

### COLORS

Refer to Polyester Color Palette at page 179.

## TECHNICAL SPECIFICATIONS



### INSTALLATION

Installation is achieved using a mechanically fixed vertical blind rail system.



### SUSTAINABILITY

Panels manufactured from 100% polyester fibre, containing a minimum of 75% post-consumer recycled PET sourced from recycled plastic bottles.



### NON TOXIC

Tested according to BS EN 717-1 (E0) for formaldehyde emissions. The panels contain no chemical binders or formaldehyde, supporting safer indoor air quality.



### FLAME RETARDANT

Panels rated Class B-s1, d0 according to EN 13501-1, offering high fire safety performance for walls and ceilings.



### MAINTENANCE

Panels can be cleaned easily using a dust broom, vacuum cleaner, or a damp cloth.



## SOUND ABSORPTION

### MODULAR PET MATERIAL

Sound class D ( $\alpha_w=0.30$ ) [according to ISO 354:2003 & ISO 11654:1997]

Absorption coefficient measurements

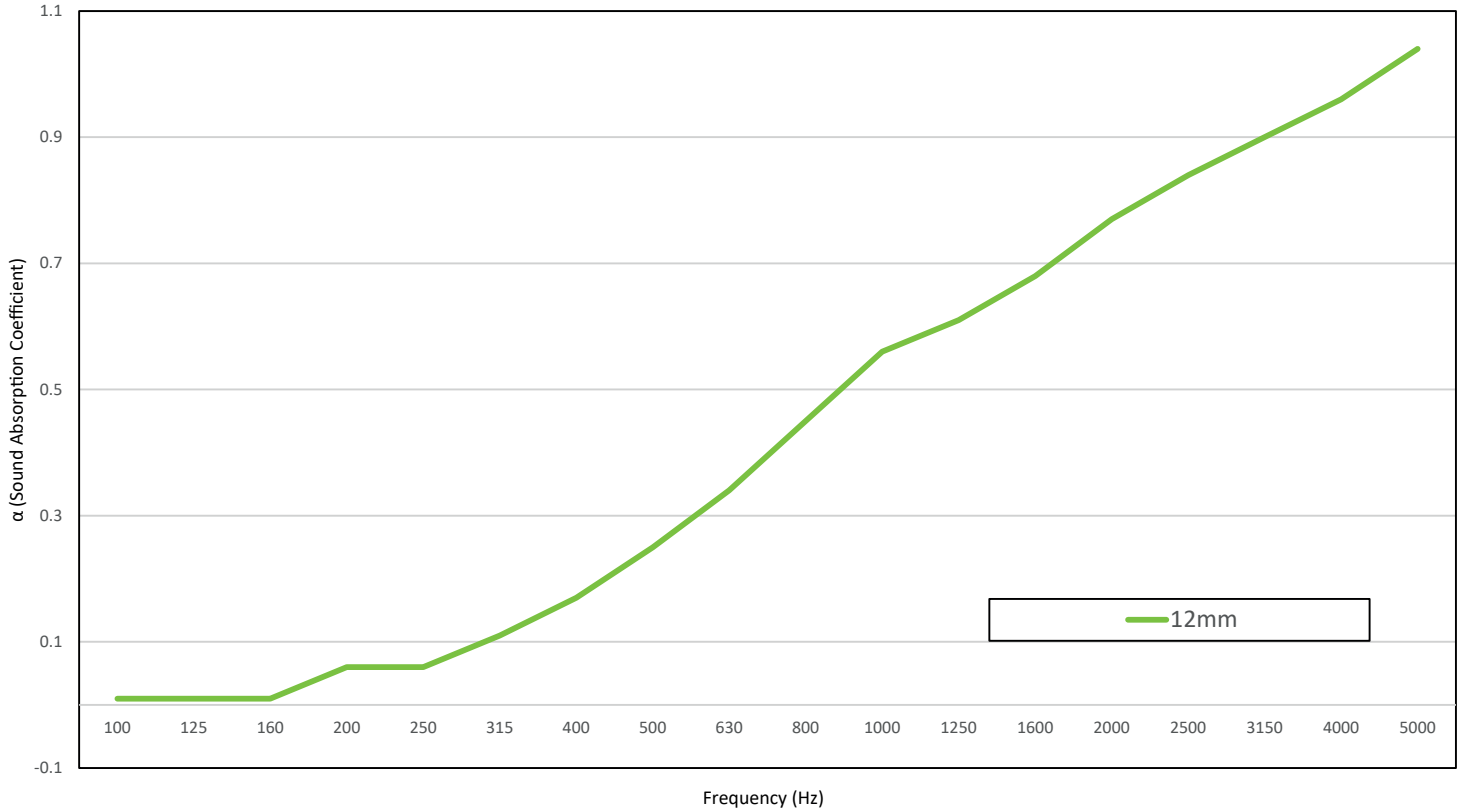

Frequency (Hz)	100	125	160	200	250	315	400	500	630	800	1000	1250	1600	2000	2500	3150	4000	5000
$\alpha_s$	0.01	0.01	0.01	0.06	0.06	0.11	0.17	0.25	0.34	0.45	0.56	0.61	0.68	0.77	0.84	0.9	0.96	1.04
12mm	0.01			0.08			0.25			0.54			0.76			0.97		

## STANDARD DIMENSIONS AND TYPES

### Standard Blinds

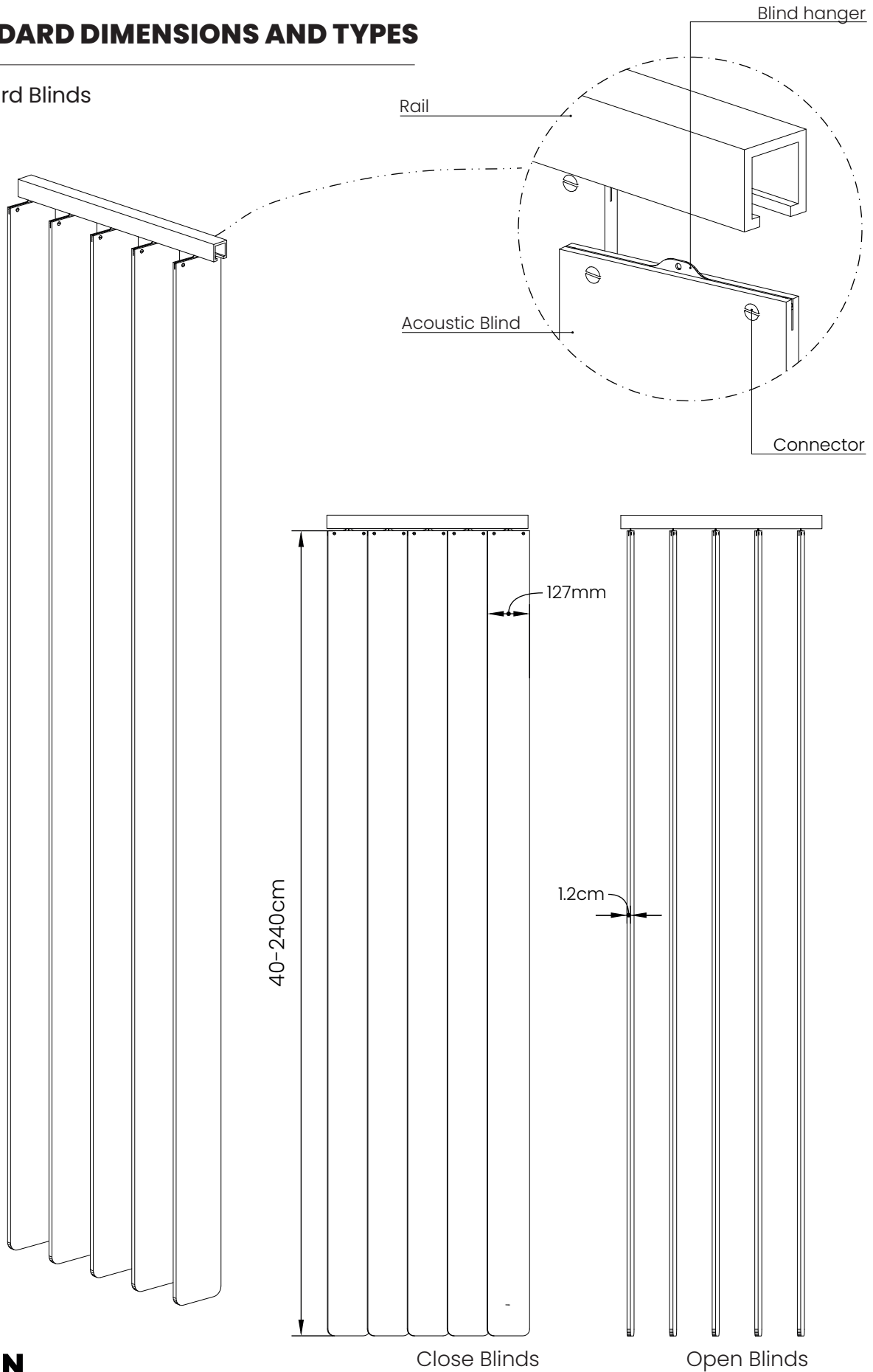

**STANDARD DIMENSIONS AND TYPES**

Extended Blinds

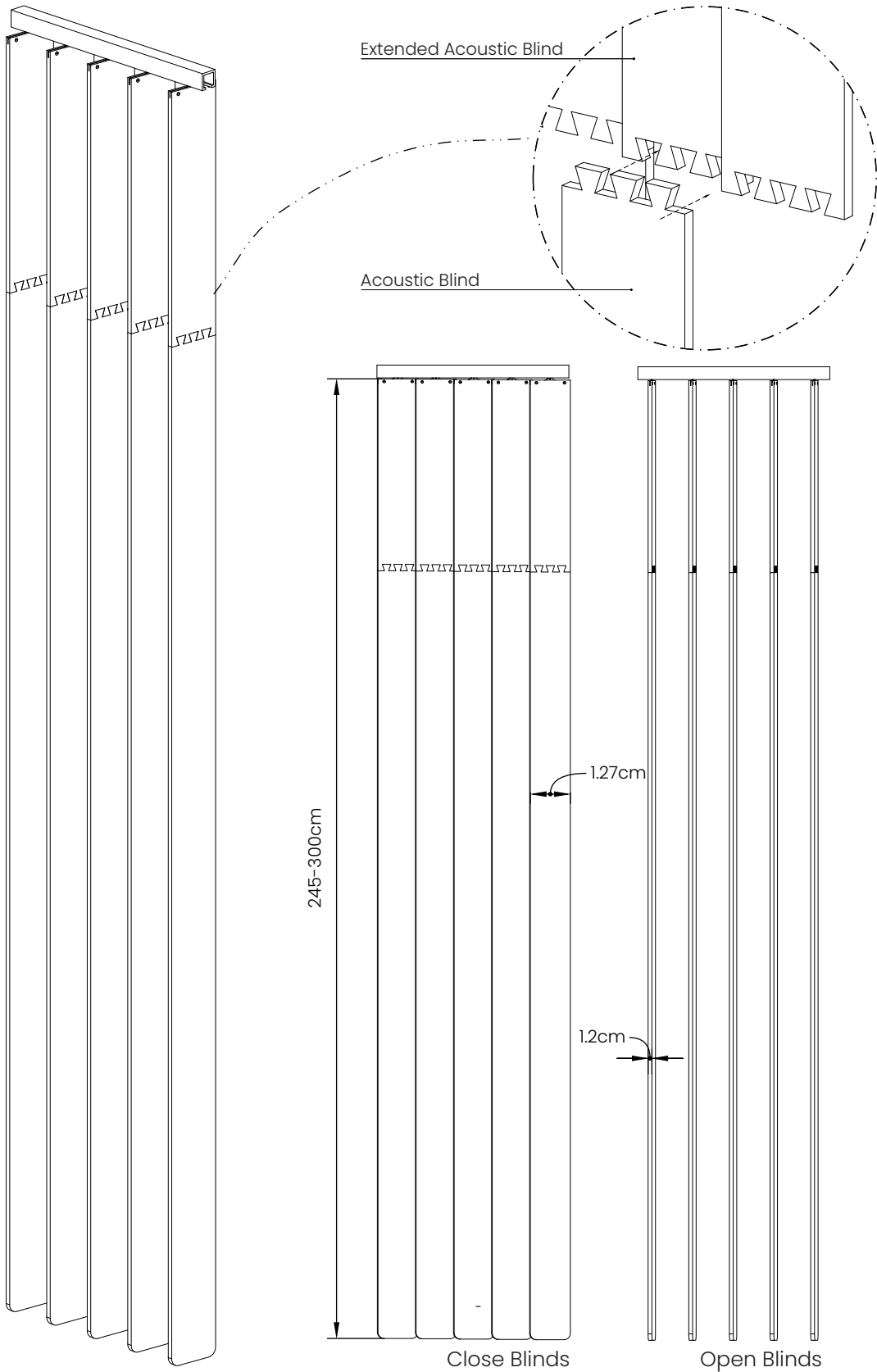



## DOORS

---

Our acoustic DOORS are engineered to provide superior sound insulation, making them the ideal solution for environments where noise control is essential. Designed with galvanised steel and precision sealing systems, these doors effectively reduce sound transmission while maintaining durability and aesthetic appeal.

All components are painted with Electrostatic Powder Coating for enhanced protection and longevity, to meet project requirements and environmental conditions.

Built for industrial, commercial and residential applications, the acoustic door combines functionality with modern design. Its solid core construction, multi-layered insulation, and perimeter sealing ensure optimal acoustic performance, minimizing noise leakage between spaces.

DOORS are the perfect choice for creating quiet, controlled environments without compromising on style or reliability.

## AVAILABLE SIZES

### STANDARD DIMENSIONS (L × W × H)

100 cm × 220 cm × 6.7 cm

### GENERAL FEATURES

- Heavy-duty lock for enhanced security.
- Concealed 3D hinges for a sleek, modern finish.

### ACOUSTIC FEATURES

- Door perimeter step around the frame for improved sound isolation.
- Rubber profiles for acoustic ceiling integration.
- Optional specialised seals for maximum sound-proofing.

### KEY FEATURES

- High sound reduction performance (up to 50dB).
- Solid core with multi-layer acoustic insulation.
- Acoustic seals for airtight closure.
- Durable, high-quality finishes.
- Custom sizes and finishes available.

### APPLICATIONS

- MEP/Plant Rooms
- Recording studios
- Offices and meeting rooms
- Hotels and hospitality spaces
- Residential properties

## MATERIALS AND COLORS

### MAIN MATERIALS

- Galvanised steel for durability and corrosion resistance.
- High-density rockwool for superior acoustic performance.

### COLORS

Refer to Aluminium Color Palette at page 180.

## TECHNICAL SPECIFICATIONS



### INSTALLATION

The acoustic door is securely mounted within a steel frame, ensuring stability, proper alignment, and optimal sound isolation.



### SUSTAINABILITY

Durable, long-lasting, and fully recyclable, reducing environmental impact.



### NON TOXIC

Safe coating with no harmful emissions under normal use.



### FLAME RETARDANT

Non-combustible, adding extra fire resistance.



### MAINTENANCE

Scratch- and corrosion-resistant, requiring minimal upkeep.

## ACOUSTICS

### SOUND INSULATION PREDICTION

Rw (C;Ctr) 50dB (-4;-11) [according to specialised software calculation]

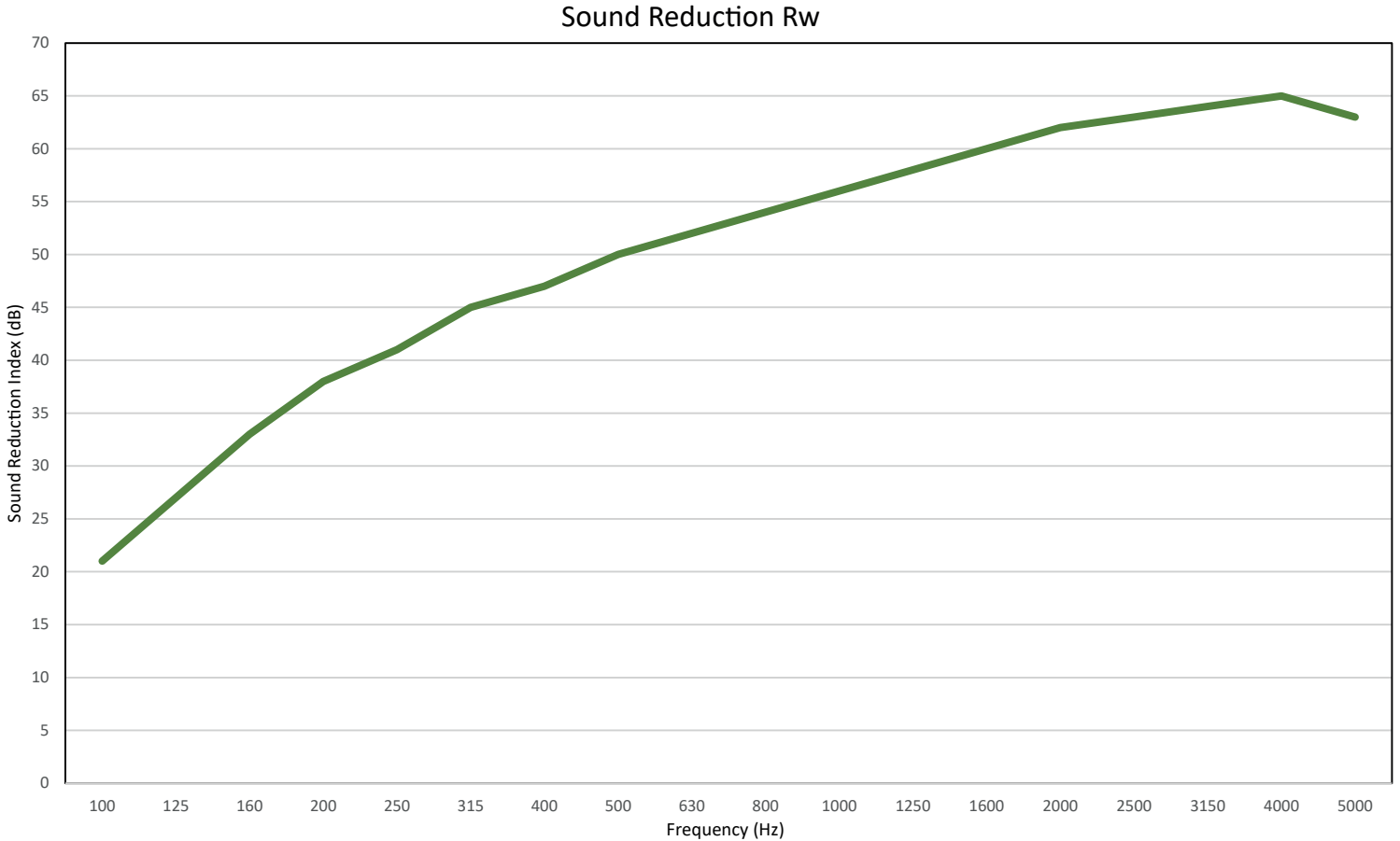

Frequency (Hz)	100	125	160	200	250	315	400	500	630	800	1000	1250	1600	2000	2500	3150	4000	5000
Rw	21	27	33	38	41	45	47	50	52	54	56	58	60	62	63	64	65	63
	0.18			41.33			49.67			56.00			61.67			64.00		

STANDARD DIMENSIONS AND TYPES

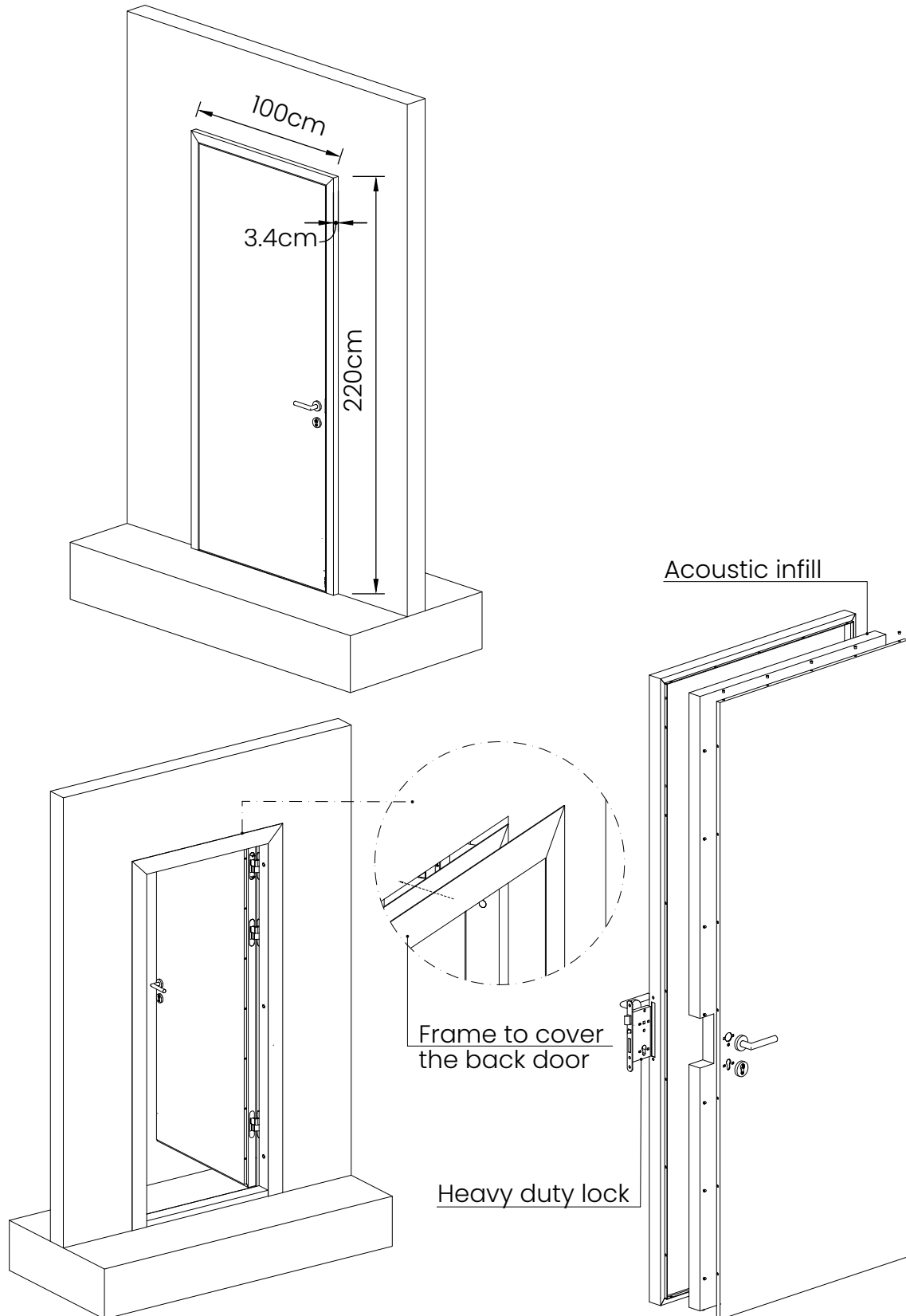

STANDARD DIMENSIONS AND TYPES

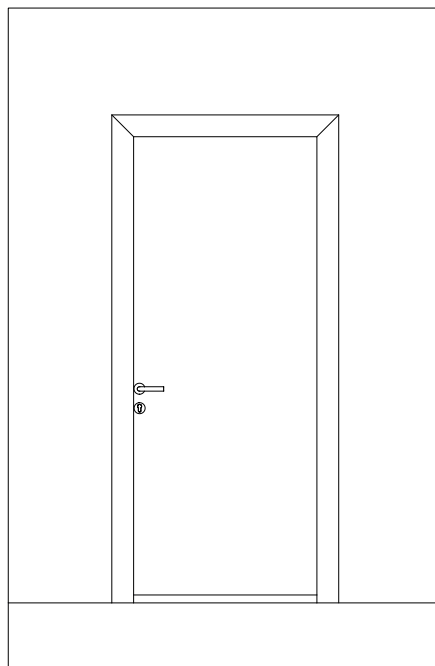
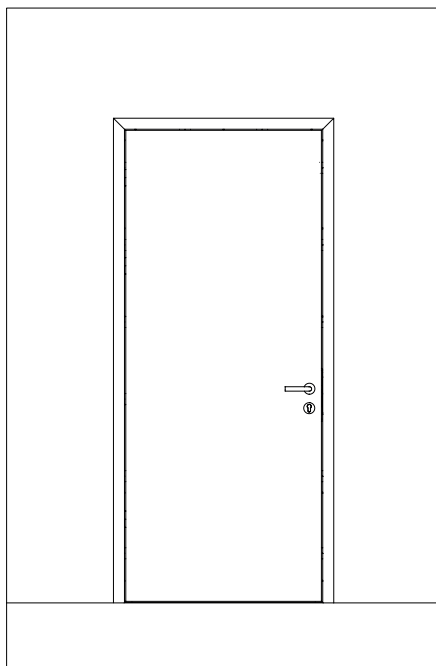
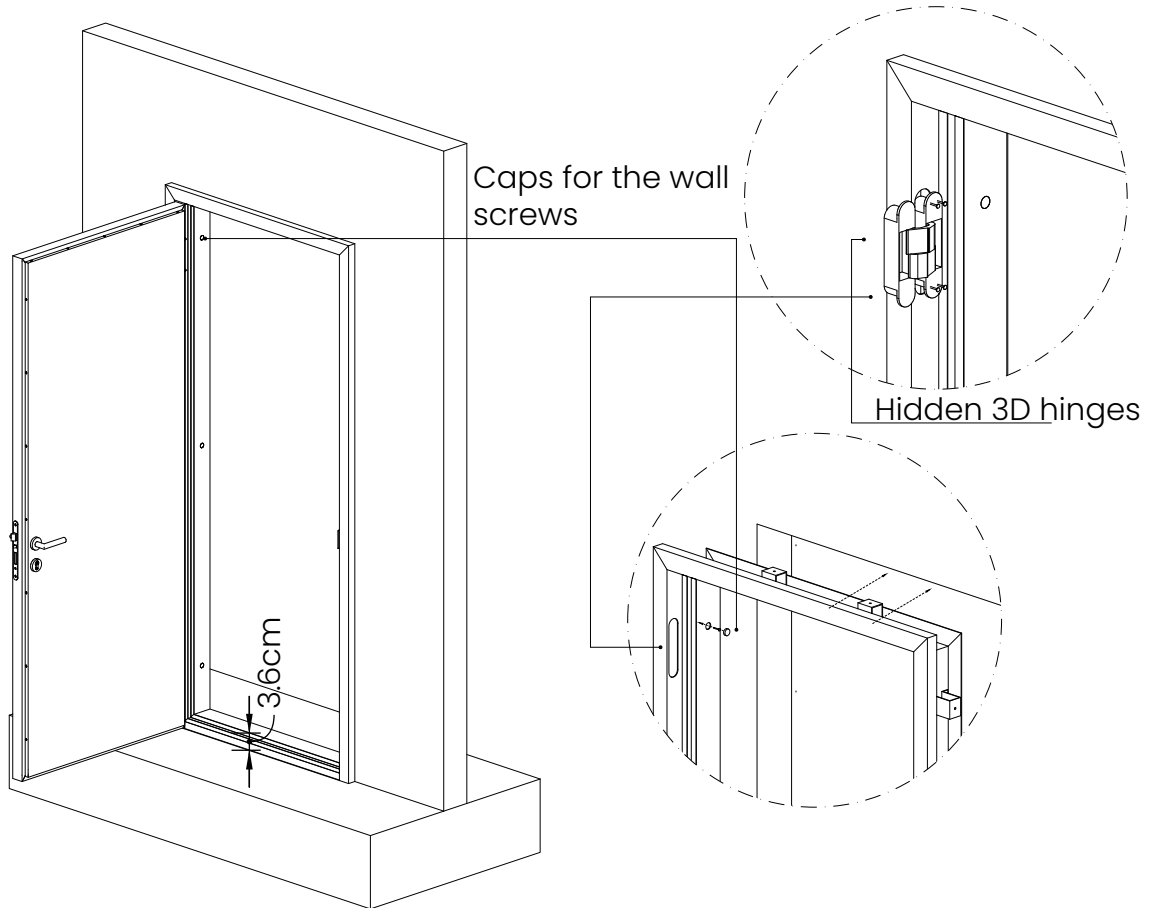



## METAL MUTE

---

METAL MUTE is an advanced acoustic barrier system designed to deliver both effective sound attenuation and high-performance sound insulation in outdoor environments. It is ideally suited for residential and commercial applications, including terraces, rooftops with mechanical equipment, and other noise-sensitive areas.

Engineered for durability and performance, this aesthetically refined metal barrier is available in a range of colours and is specifically designed to withstand ultraviolet radiation, water exposure, and demanding outdoor conditions.

The system features a modular design, primarily composed of acoustic sandwich panels supported by a robust galvanised steel frame. The panels are constructed from high-quality aluminium, rockwool insulation, and a breathable fabric layer, ensuring optimal acoustic performance and long-term reliability.

All components are painted with electrostatic powder coating for enhanced protection and longevity, to meet project requirements and environmental conditions.



## AVAILABLE SIZES

### SANDWICH PANEL UNIT

180 cm × 80 cm (L × H)

### PANEL THICKNESS

56 mm

### OVERALL SYSTEM DIMENSIONS

Configurable according to project requirements, site constraints, and acoustic study outcomes.

## TYPICAL APPLICATIONS

- Residential and commercial outdoor areas.
- Entertainment venues and outdoor live music.
- Mechanical and plant rooms.
- Rooftops and terraces with MEP equipment.

## MATERIALS AND COLORS

### MATERIALS

- Supporting structure – frame:
- Made from galvanised steel, painted accordingly.
  - Design according to project needs and other consultants' specifications.
  - Steel plate and anchor screws for base support.

### COLORS

Refer to Aluminium Color Palette at page 180.

## TECHNICAL SPECIFICATIONS



### INSTALLATION

Installation is achieved through mechanical fixing to walls or ceilings, or by mounting as noise barriers within a steel frame structure.



### SUPPORTING STRUCTURE

The barrier system is supported by a galvanised steel framework, constructed using structural hollow sections (SHS), steel plates, and high-grade fastening elements. The modular design allows each barrier panel to be securely installed by sliding it into position above the preceding panel, ensuring ease of installation, structural stability, and precise alignment.



### FIRE RESISTANCE RATING

The system is designed for durability in outdoor environments and is suitable for use in demanding weather and coastal conditions.



### MAINTENANCE

The system requires minimal maintenance and can be easily cleaned using a soft brush, vacuum cleaner, or a damp, well-wrung cloth.



### WEATHER & COASTAL CONDITIONS

The system is designed for durability in outdoor environments and is suitable for use in demanding weather and coastal conditions.



### STRUCTURAL DESIGN

Structural design and load calculations are carried out in accordance with applicable standards, including CYS and relevant international codes, as detailed in the project-specific engineering report.



### TECHNICAL DOCUMENTATION

Comprehensive technical documentation is provided, including product brochures, material inspection reports, and certification of specifications for all system components.



### ADDITIONAL PROPERTIES

- High resistance to ultraviolet (UV) radiation.
- Recyclable materials.
- Optimized weight-to-surface ratio for efficient structural performance.



## ACOUSTICS

### SOUND REDUCTION (PERFORMANCE)

Rw = 31dB [According to ISO 10140-2, ISO717.1]

### SOUND ABSORPTION (PERFORMANCE)

Sound Class A (aw=0.9) [According to ISO 11654:1997]

### SOUND ATTENUATION (OF THE SYSTEM)

The acoustic performance of the system depends on barrier height, length, and configuration, as well as the relative positions of the noise source and receiver. Expected sound attenuation levels are determined through project-specific acoustic studies and simulations to ensure optimal performance for each application.

Absorption coefficient Testing

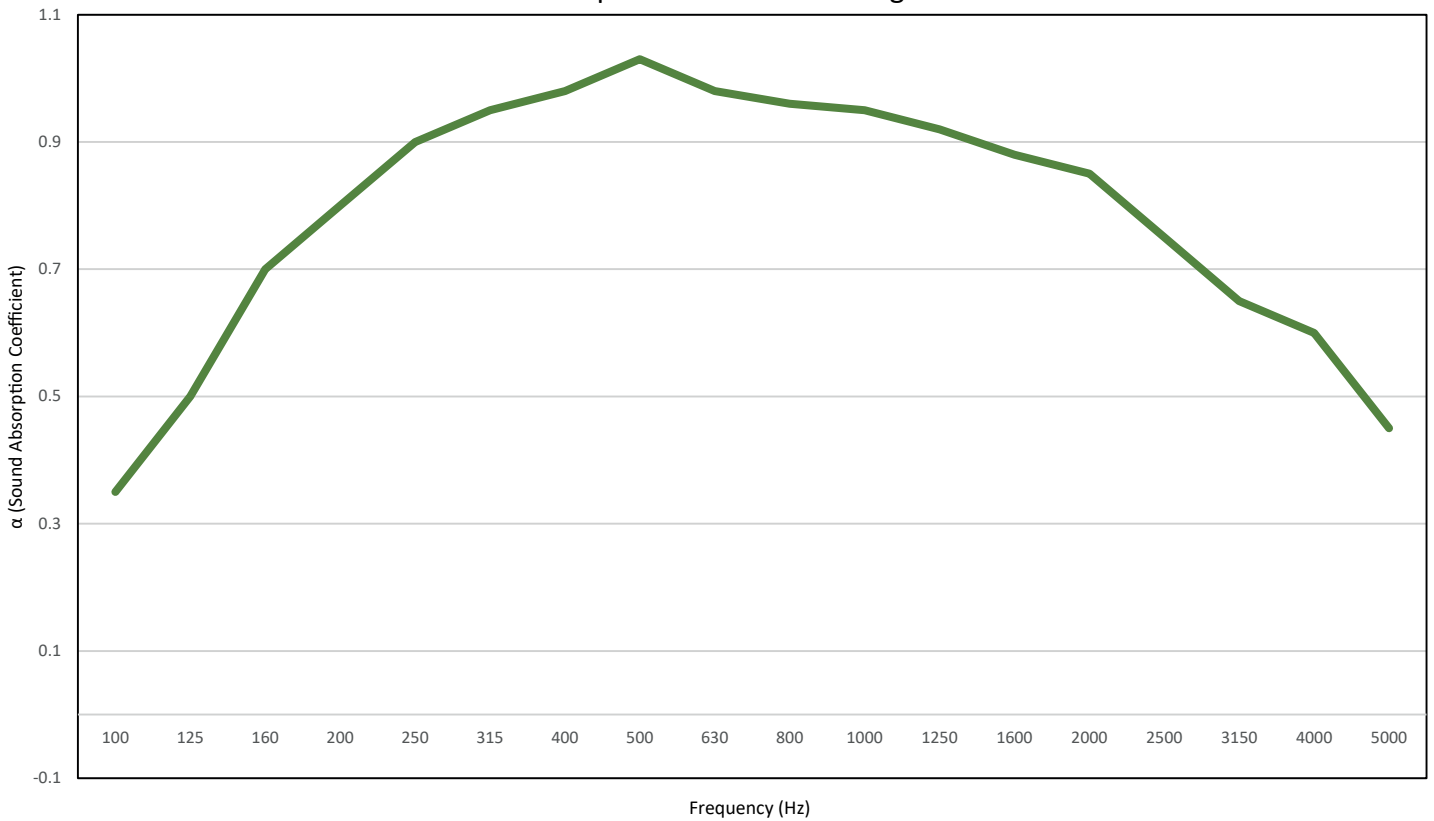

Frequency (Hz)	100	125	160	200	250	315	400	500	630	800	1000	1250	1600	2000	2500	3150	4000	5000
aw	0.35	0.5	0.7	0.8	0.9	0.95	0.98	1.03	0.98	0.96	0.95	0.92	0.88	0.85	0.75	0.65	0.6	0.45
	0.52			0.88			1.00			0.94			0.83			0.57		

## STANDARD DIMENSIONS AND TYPES

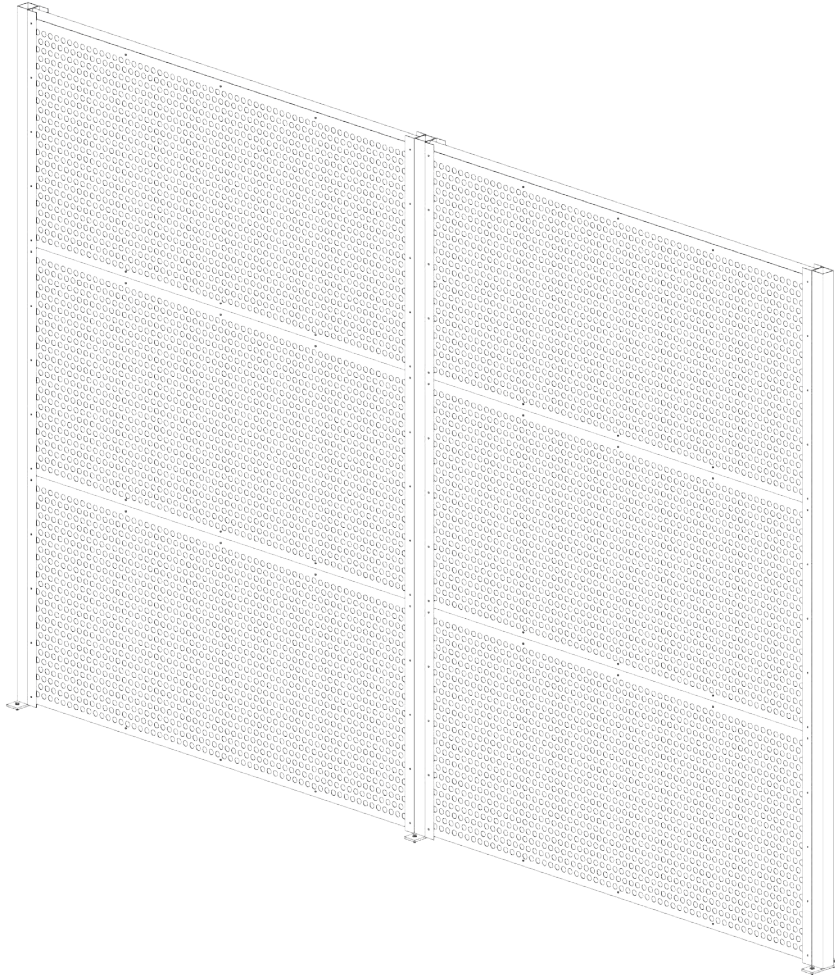

Front view

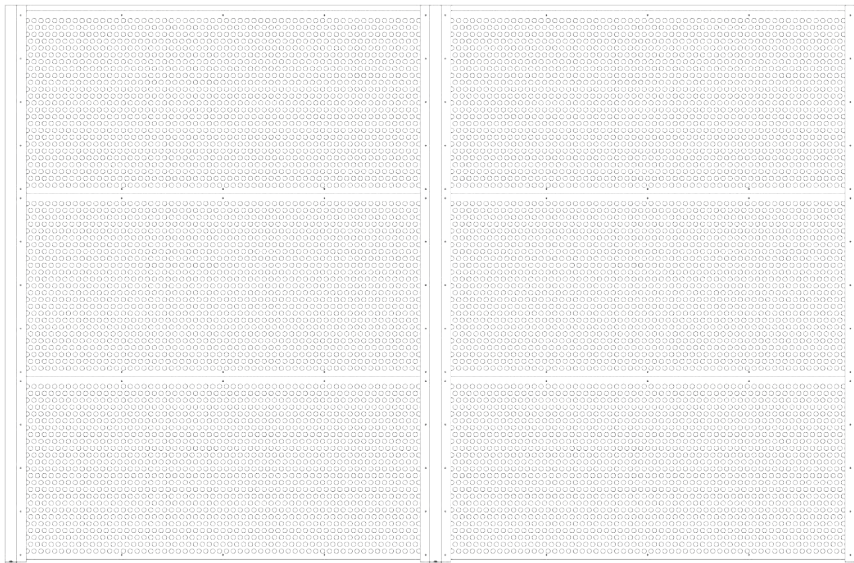

**STANDARD DIMENSIONS AND TYPES**

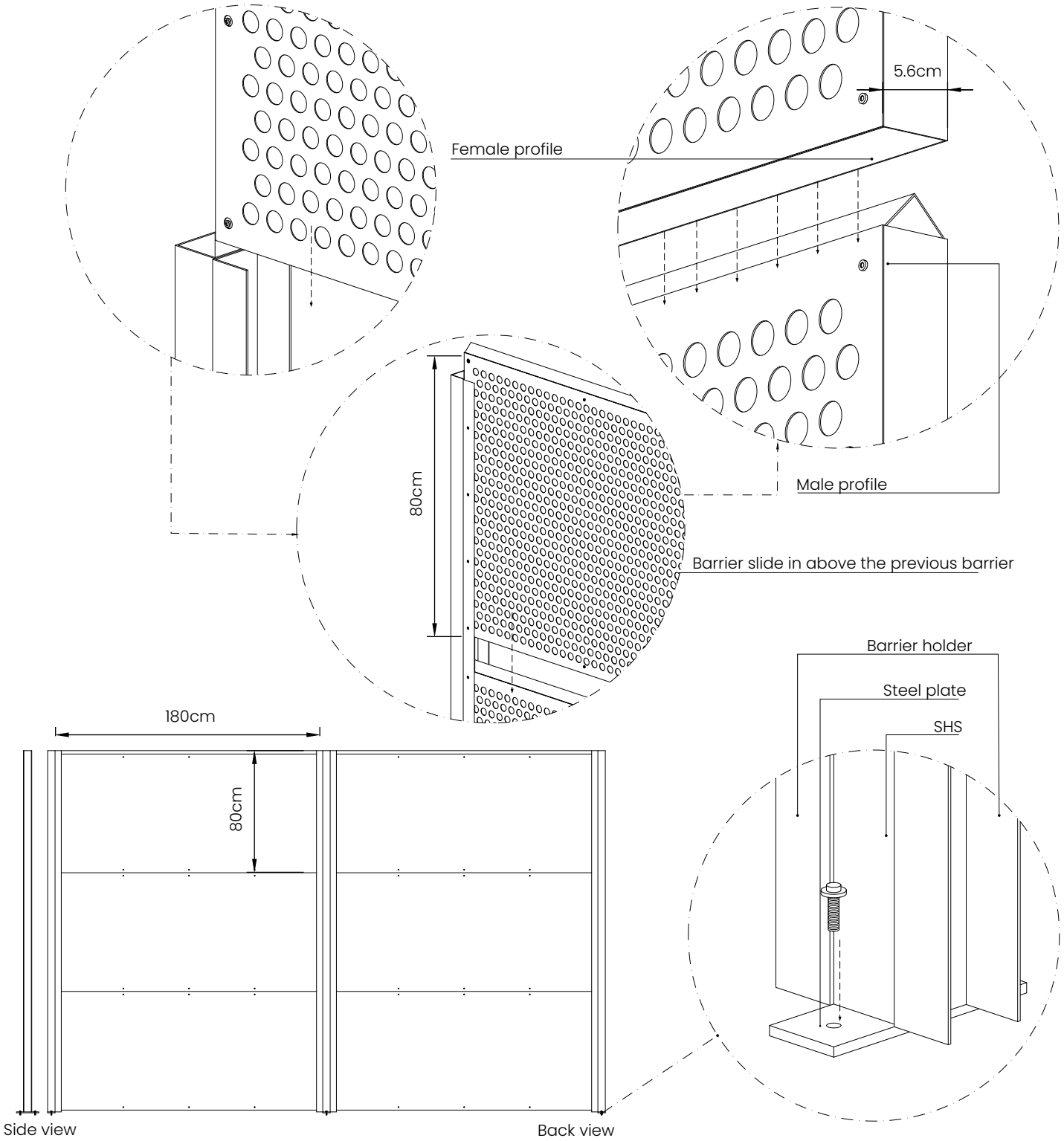



## **FSS**

---

The Splitter Silencer System (FSS) is engineered for high-performance sound attenuation and natural ventilation in plant rooms, mechanical levels, and equipment areas. The system combines aluminum silencers with a galvanised steel supporting structure for durability and structural integrity.

All components are painted with Electrostatic Powder Coating for enhanced protection and longevity, to meet project requirements and environmental conditions. Additionally, a protective hood or wire mesh can be installed to prevent intrusion by birds and insects.

The system is scientifically designed to achieve an optimal balance of acoustic performance, low pressure drop, and rain protection, making it suitable for industrial environments. Its modular construction consists of custom-made splitter silencers, allowing flexible configurations for diverse industrial applications.

A laser-cut bracket system enables customized mounting on existing façade openings or pre-fabricated steel structures, simplifying installation and integration.



## AVAILABLE SIZES

### HEIGHT

Up to 285 cm

### DEPTH

60cm

### SPLITTERS WIDTH

10 cm

### SPLITTER TO SPLITTER GAP

5 cm

### Facade opening area

33%

\*Other sizes upon request

## MATERIALS AND COLORS

### MATERIALS

Supporting structure and brackets-stoppers-clips are made of galvanized steel.

Steel structure design according to project needs and other consultants' specifications.

Brackets, stoppers & clips for stability and removal (maintenance) purpose.

### COLORS

Refer to Aluminium Color Palette at page 180.

## TYPICAL APPLICATIONS

- Mechanical Rooms
- Generator Rooms
- Roof MEP Installations
- Mechanical Levels Facade
- Workshop Fresh Air Inlets/Outlets

## TECHNICAL SPECIFICATIONS



### INSTALLATION

Installation is achieved by mechanically mounting metal brackets within a steel frame structure.



### SUPPORTING STRUCTURE

Galvanized steel construction ensures durability, while brackets, stoppers, and clips provide stability and easy maintenance. Custom-designed to meet project and consultant requirements.



### PRESSURE DROP – DIFFERENTIAL PRESSURE

Calculated for each project based on airflow, opening area, and relevant system properties.



### MAINTENANCE

Can be cleaned using a dust broom, vacuum cleaner, or damp cloth.



### WEATHER & COASTAL CONDITIONS

Suitable for outdoor installations, including exposure to coastal environments.



### STRUCTURAL DESIGN

Structural calculations and analysis performed according to CYS and relevant standards.



### TECHNICAL DOCUMENTATION

Technical brochures, material inspections, and specification certificates are available for each system component.

## SOUND ATTENUATION

FSS OF STANDARD DIMENSIONS H-D-W-G: 2600-600-100-50MM

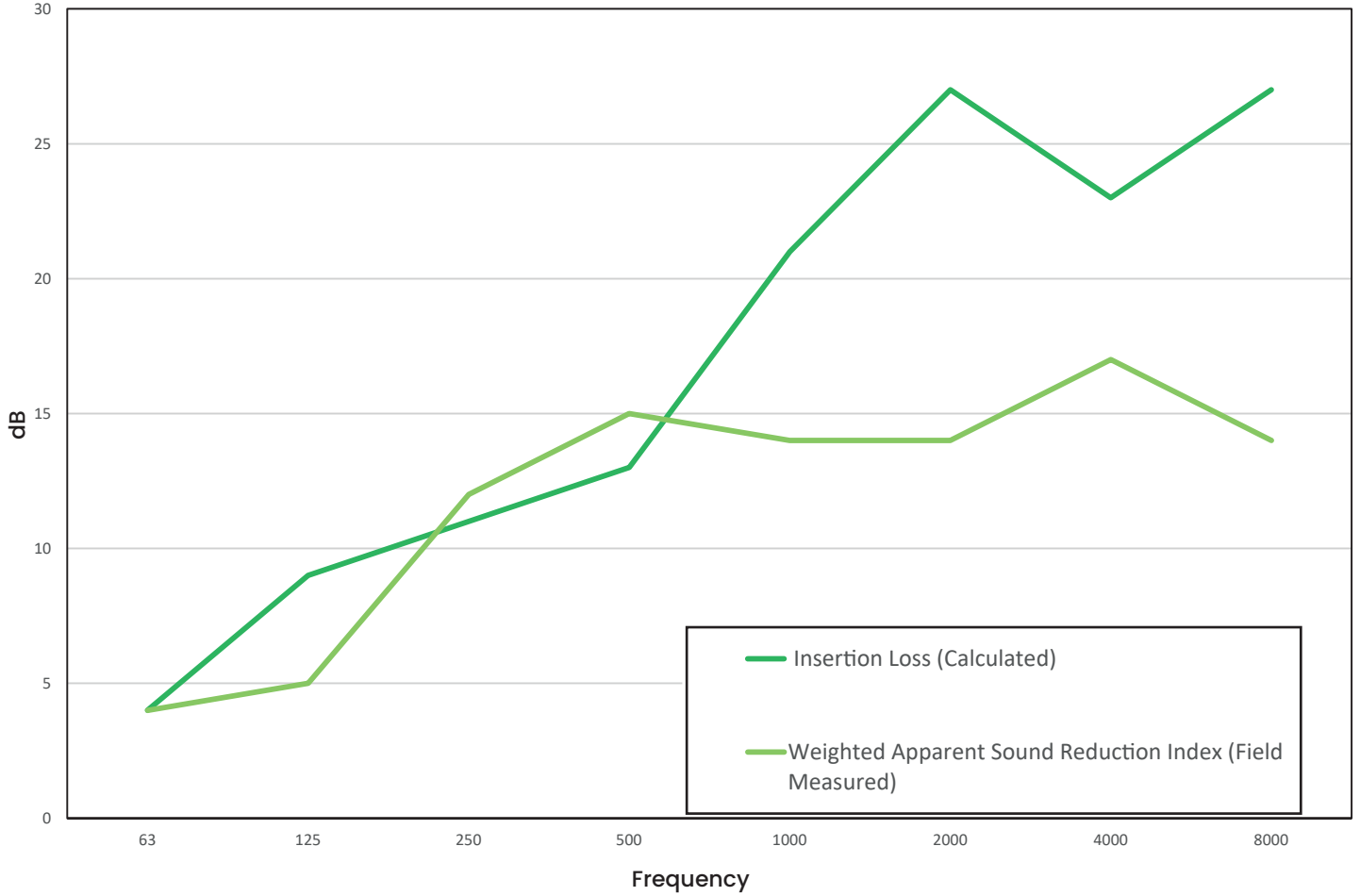

---

## SOUND ATTENUATION

---

<b>ACOUSTIC CALCULATIONS</b>								
<b>Frequency (Hz)</b>	63	125	250	500	1000	2000	4000	8000
<b>Insertion Loss (dB)</b>	4	9	11	13	21	27	23	17

(Based on calculation of specialized acoustic simulation software)

Splitters' width-gap: 100mm-50mm , Airflow: 30 600 m<sup>3</sup>/h

Differential Pressure: Lower than 5Pa , Airflow velocity in the airway: 2.6m/s, Opening Area: 33%

\*Calculations are performed for each project based on the required dimensions.

<b>FIELD MEASUREMENTS</b>								
<b>Frequency (Hz)</b>	63	125	250	500	1000	2000	4000	8000
<b>Weighted Apparent Sound Reduction Index (dB)</b>	4	5	12	15	14	14	17	14

(Based on field measurements according to ISO 16283-3)

Splitters' width-gap: 100mm-50mm , Opening Area: 33%



**STANDARD DIMENSIONS AND TYPES**

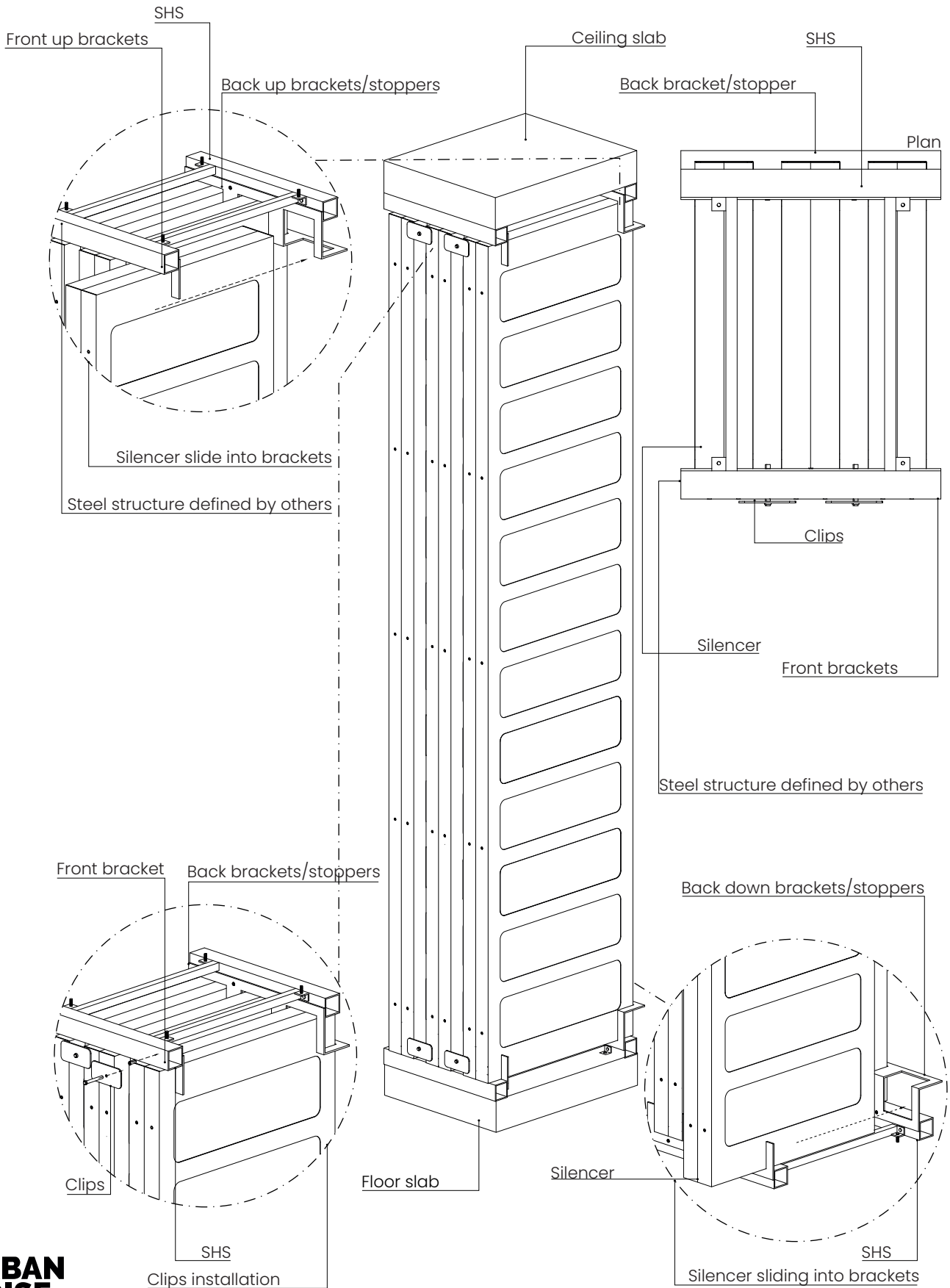



## STANDARD DIMENSIONS AND TYPES

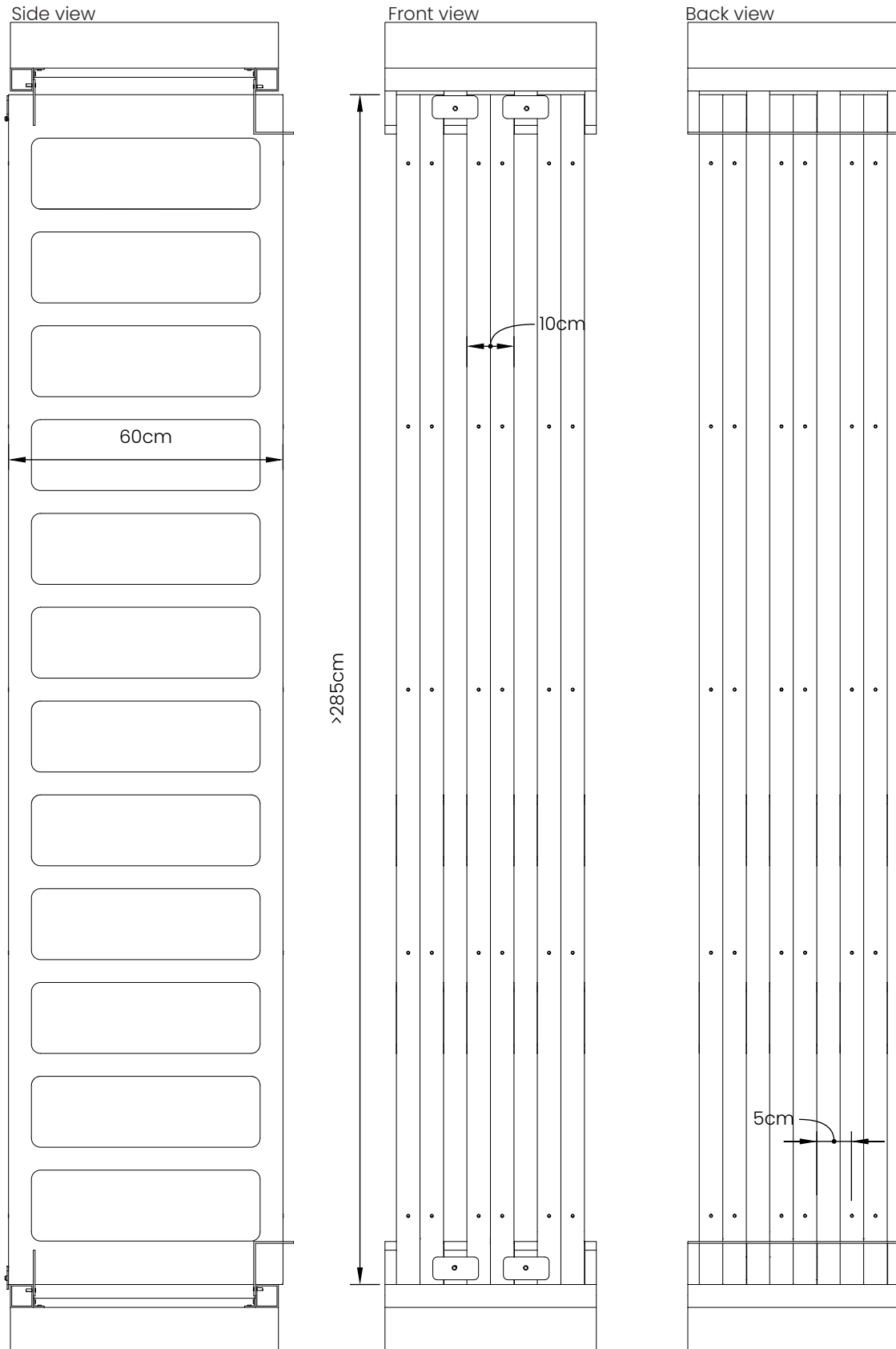



## STANDARD DIMENSIONS AND TYPES

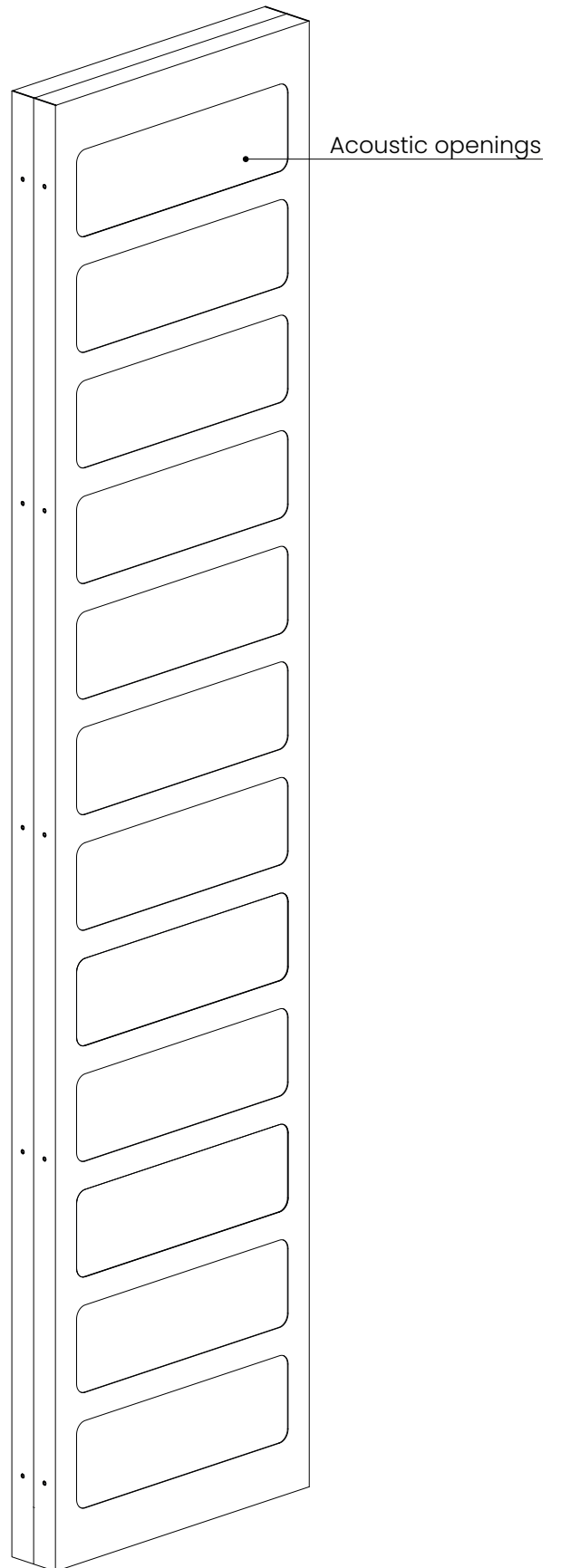
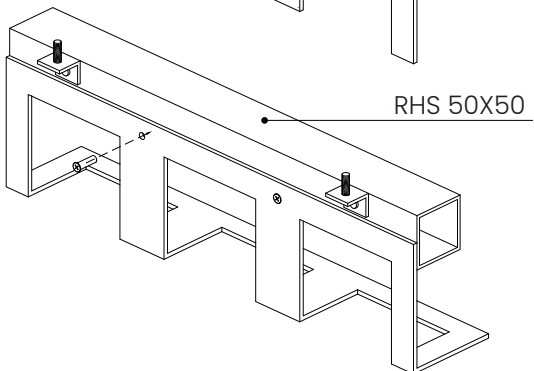
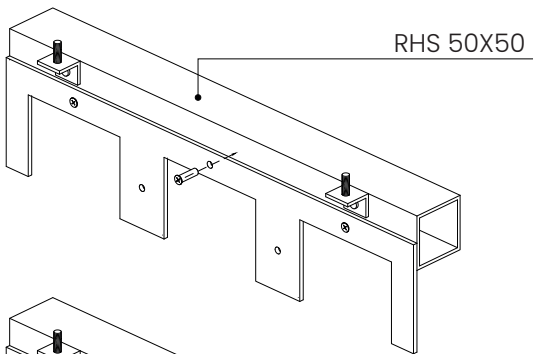
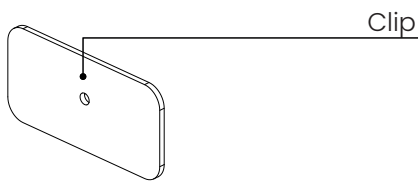
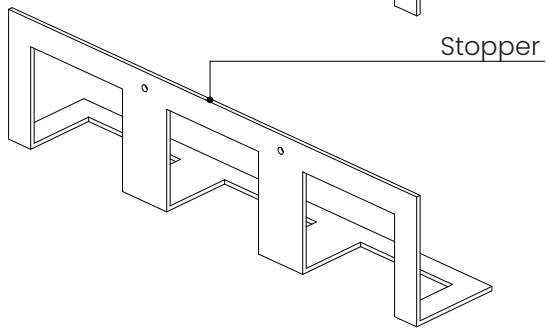
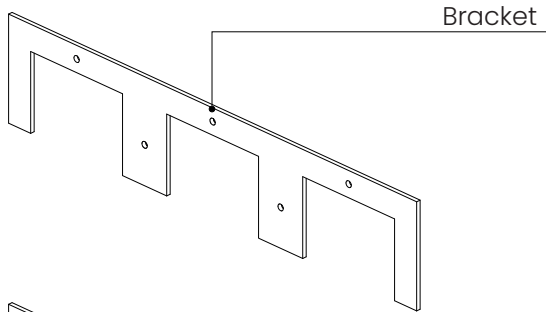



## COLOR PALETTES

---

## POLYESTER FIBER COLORS

Available colors for the below systems:

- POLYSOUND
- M-SYSTEM
- MODULAR
- EXTRUDED
- BLINDS
- TESSERA



### POLYESTER FIBER

100% made from recycled PET

---

## ALUMINIUM COLORS

---

Available colors for the below systems:

- DOORS
- METAL MUTE
- FSS



---

## WOOD COLORS

---

Available colors for the below system:

- SOUNDWALL

### MDF IMPREGNATED COLORS



### MDF WOOD COLORS

---

## FABRIC COLORS

---

Available colors for  
the below systems:

- STAND ALONES
- DESK DIVIDERS

